

Nederman

NFZ3000 Chip & Dust Filter

**Nederman – the optimum choice for
your dust extraction system**





Typical dust control and process applications

- Timber and Wood working machinery
- Furniture production
- Lightweight bulk materials

NFZ3000 Features



The NFZ3000 filter is a compact filter, well suited for any air flow with heavy material content.

The NFZ3000 filter is designed with a basic module size of 1200 x 1200 mm. The design makes it possible to add modules if the capacity is increased.

The filter is self-supporting; it has telescopic supporting legs and is suitable for outdoor locations.

Each module (either 1200 or 2400 mm wide) of the filter construction is fitted with a combined inspection and explosion relief door. Regeneration fans are fitted for easy and effective cleaning of the filter bags. The NFZ3000 filter is fitted with the unique patented Nederman SUPERBAG filter bag.

The filter hopper and the inlet section (optional) separate the particles and distribute the air to the filter bags. The collected material can be removed through a wide range of discharge and waste handling options.

- **Full filter range covering air flows from 1,500 to 500,000 m³/h (1,000 to 300,000 cfm)**
- **Modular galvanized steel construction**
- **Easy to install on site and extend if required**
- **ATEX certified for St1 and St2 dust with a Kst value up to 300 bar m/s.**
- **Available for positive or negative pressure operation**
- **Low power consumption**
- **Powerful on-line cleaning by efficient regeneration fans**
- **Patented polyester SUPERBAG filter bags**
- **Wide range of discharge and waste handling options**

Specifications	
Temperature	Max. 75°C
Over pressure	Max. 800 Pa
Vacuum	Max. 5000 Pa
Power supply	· 230 / 400 V · Chain motor – 1.1 kW (for NFKZ3000 filter)
Door switch	· At the inspection doors in the filter hopper · At one filter module door per each 5 modules · At each inlet module door
Filter element	Superbag 2000 XT15 with ø200 mm collar
Filter area per module	HJ: 85 m ² - LJ: 40 m ² - HE: 42 m ² - LE: 20 m ²

How it works

....during normal operation

1. During normal operation, the dust laden air from the plant travels down the supply duct **1**.
2. The dirty air then enters the filter **2**.
3. As the dust laden air enters the inlet section of the filter **15**, the air decelerates and heavier dust and shavings settle on the hopper floor **3**.
4. The heavier dust and shavings collected on the hopper floor are conveyed to the discharge end **11** of the filter by the scrapers on the chain conveyor **8**.
5. At the discharge end of the filter, the dust is removed **11**.
6. The remaining dust then travels up into the inside of the filter bags **5**. Each filter module **14** has 25 filter bags.
7. The air, which originated from the plant, is now clean **6** and passes through the filter bag and out the exhaust port **7**.

....while cleaning

1. The filter cleans the bags during operation (on-line cleaning) and when the unit is shut down (off-line cleaning). The off-line cleaning period starts after the COMBIFAB fan **4** has stopped rotating.
2. A PLC control in the electrical panel regulates the cycle of the reverse air regeneration fan. **7** The regeneration fan shakes the filter bags **5** causing the dust cake, which hangs on the inside of the filter bag, to fall into the hopper section **3**.
3. Any dust that remains on the inside of the filter bag after the initial "shake" is removed by the airflow **16** generated by the regeneration fan.
4. The dust that is removed during the cleaning cycle falls on the floor of the hopper **3**, and is then transported to the discharge section of the filter **11** by the chain conveyor **8**.

NOTE: The back pressure flap **12** is open during normal operation of the filter but closes when the fan is shut down and the filter starts in an off-line cleaning cycle. During the off-line cleaning period, the back pressure flap **12** acts as a barrier to prevent the air generated from the regeneration fan from travelling back down the supply duct **1**.

How it works

Normal operation - overpressure version

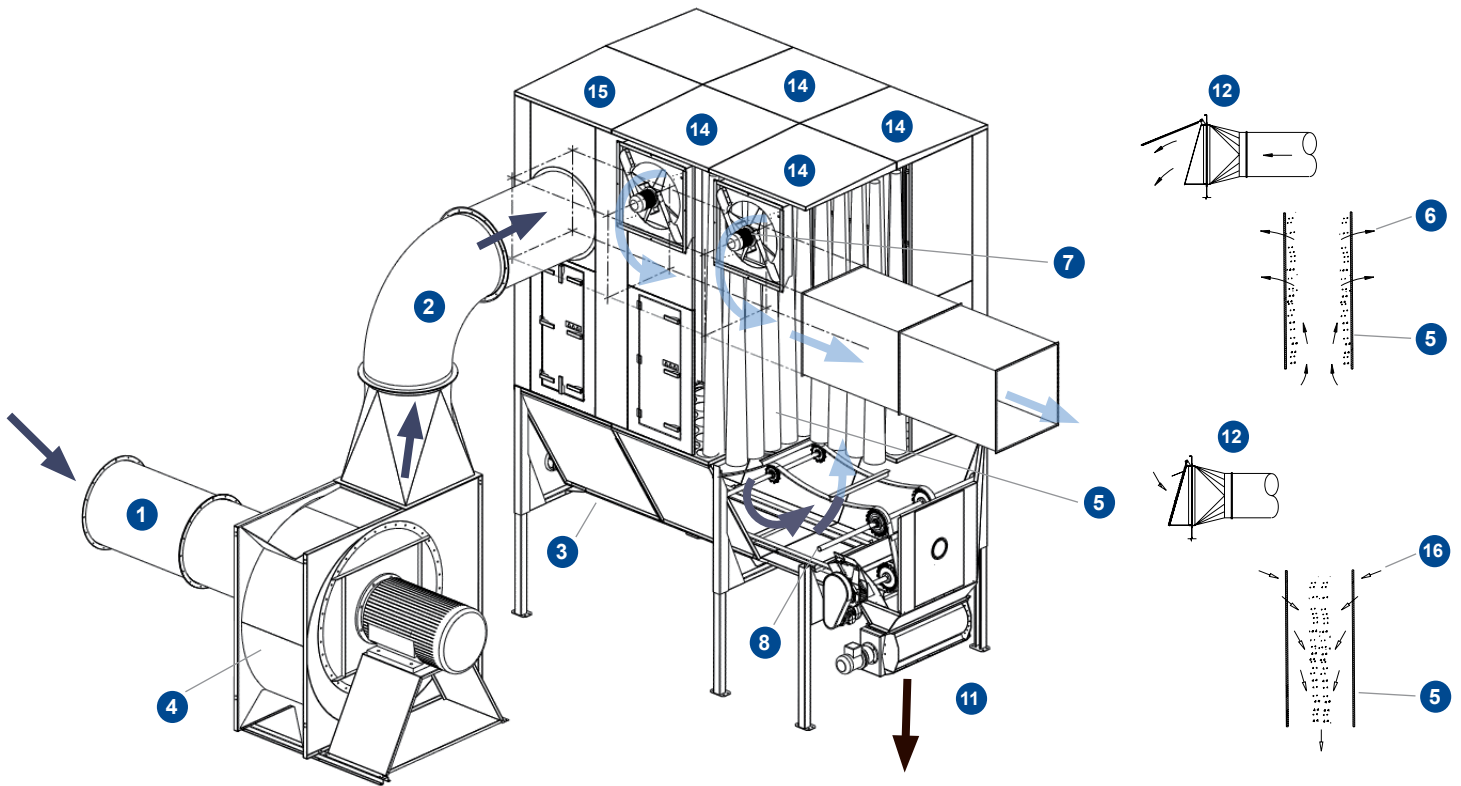

Normal operation - vacuum version

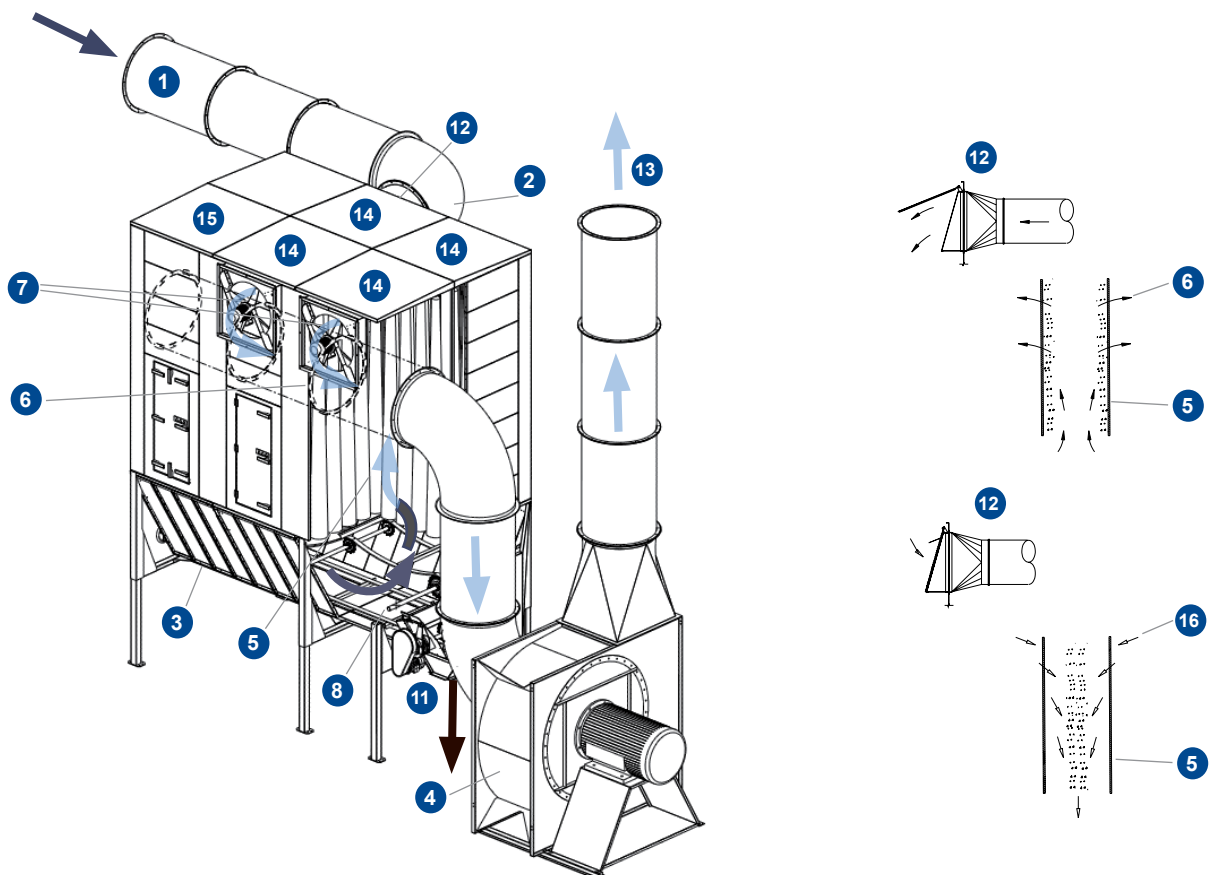



NFKZ3000 Filter with chain conveyor

The NFKZ3000 filter with chain conveyor is a compact filter, suited for handling large air flows with heavy material content.

The filter hopper and the inlet section (optional) separate the medium/large particles and distribute the air to the filter bags. A double chain conveyor in the bottom of the hopper moves the collected material to a rotary valve for outfeeding.

The filter can be supplied for either continuous operation or with a pause for cleaning of the filter bags every four hours.

- **Handles air flows from 10,000 – 500,000 m³/h (5,000 – 300,000 cfm)**
- **Compact design**
- **ATEX certified for St1 or St2 dust**
- **Easy to extend**
- **To be mounted either on the ground or on the roof**
- **Available for positive or negative pressure operation**
- **Explosion venting upwards or at side**
- **Available in J module size (1200 x 2400 mm)**

View from the inside of the hopper



NFKZ3000 Filter with chain conveyor

Planning-in

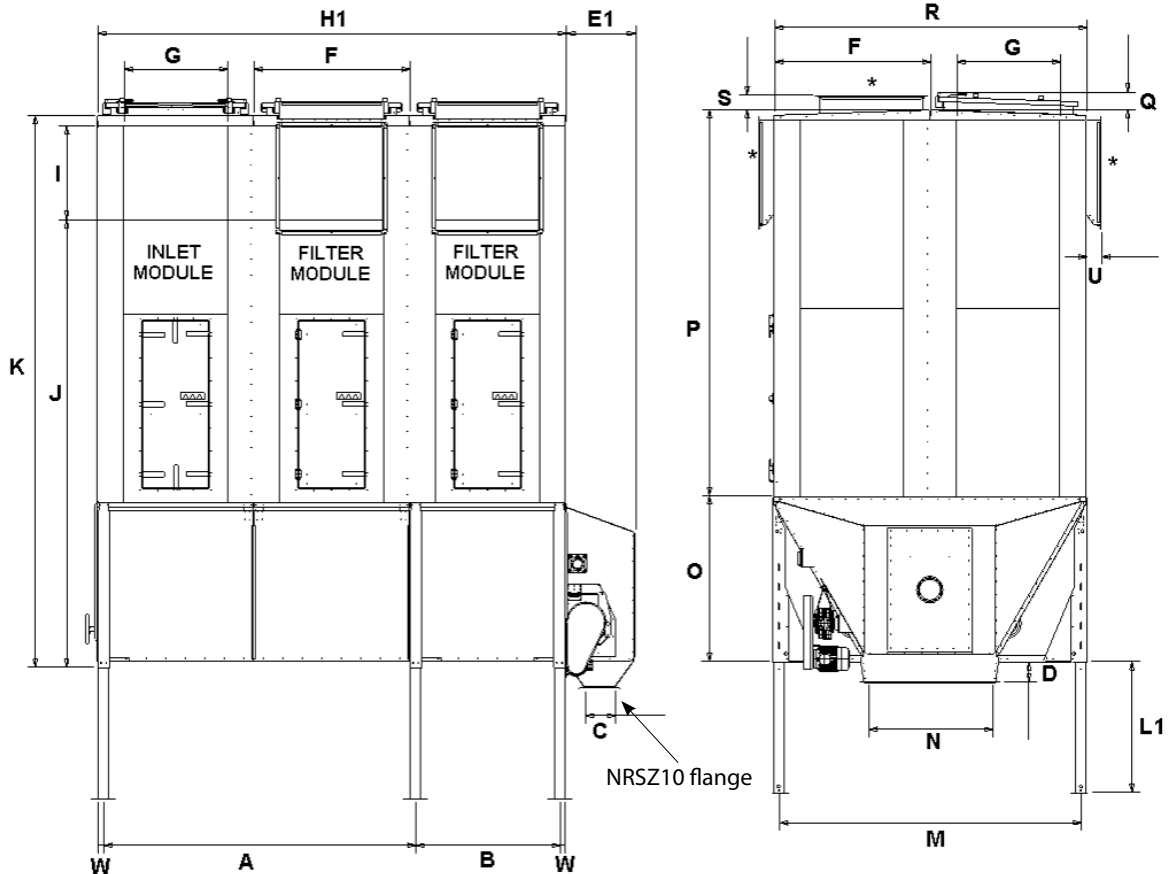

Example: NFKZ3000 2+1 HJ

Type	A#	B	C	D	E1	F	G	H1	I	J**	K**	L1	M	N	O	P**	Q	R	S	U	W
J	2400	1106	245	153	583	1200	800	3600	720	3420	4230	See below	2321	952	1260	2960	135	2400	115	150	47

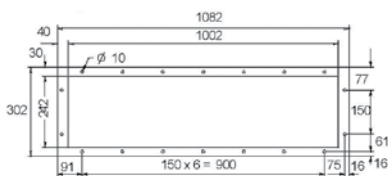

NRSZ10 flange

L1 – telescopic filter legs

Type	Min. Adjust.	Max. Adjust.
L = 1596 mm	555	1250
L = 2195 mm	1155	1850
L = 2596 mm	1555	2250

* Optional position of outlet /reg. fan. 800 x 800 or 600 x 600 mm (LJ version: not on door side)

** Height of LJ version – reduce 1440 mm

Optional 1200 mm

All dimensions in mm.



NFSZ3000 Filter with rotary valve

The NFSZ3000 filter with rotary valve is designed for small and medium-sized air flows with large material content.

The medium/large particles are separated in the filter hopper (inlet section optional) and the air is afterwards distributed to the filter bags. The collected material is discharged through the rotary valve.

The filter is typically used in situations requiring non-pressurised material discharge directly into a silo, container or separate material transport system.

The filter can be supplied for either continuous operation or with a pause for cleaning of the filter bags every four hours.

- **Handles air flows from 5,000 – 60,000 m³/h (3,000 – 35,000 cfm)**
- **Available for positive or negative pressure operation**
- **Easy installation of pre-assembled top and hopper on site**
- **ATEX certified for St1 or St2 dust**
- **Wide range of rotary valves for discharge**
- **Available in two widths, type E and J**



NFSZ3000 Filter with rotary valve

Planning-in

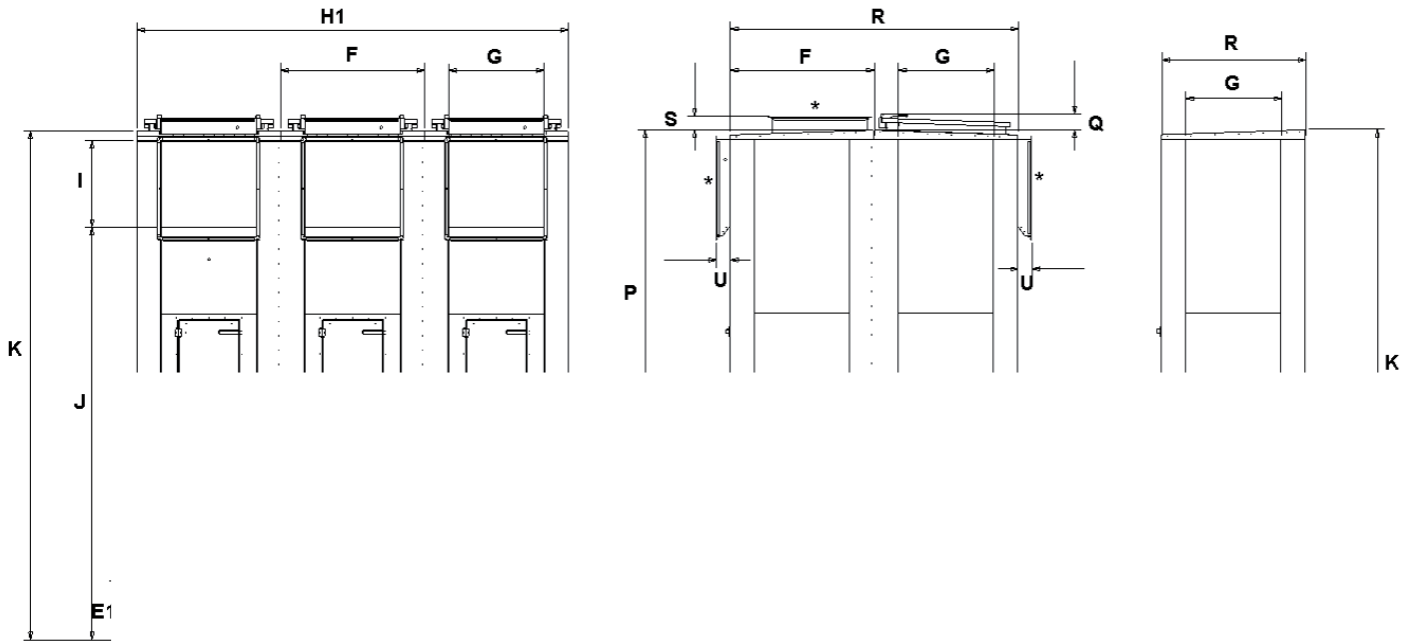

Example: NFSZ3000 3 HJ

Type J (1200 x 2400 mm)

Type E (1200 x 1200 mm)

Type	A#	B	C	E1***	F	G	H1	I	J**	K**	L1	M	N	O	P**	Q	R	S	U	W	X	Z
E	2400	1106	952	485	1200	800	3600	720	2937	3737	See below	1121	240	780	2960	135	1200	115	115	47	115	480
J	2400	1106	952	485	1200	800	3600	720	3420	4220	See below	2321	240	1260	2960	135	2400	115	115	47	115	

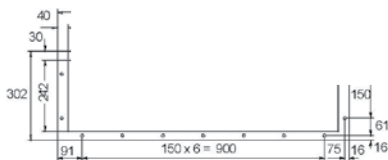

NRSZ10 flange

L1 – telescopic filter legs

Type	Min. Adjust.	Max. Adjust.
L = 1196 mm	155	850
L = 1596 mm	555	1250
L = 2195 mm	1155	1850
L = 2596 mm	1555	2250

No. of modules	H1	No. of modules	H1
1 HJ & LJ	1200	1 HE & LE	1200
2 HJ & LJ	2400	2 HE & LE	2400
3 HJ & LJ	3600	3 HE & LE	3600
4 HJ & LJ	4800	4 HE & LE	4800
5 HJ & LJ	6000		
6 HJ & LJ	7200		

Optional 1200 mm

* Optional position of outlet /reg. fan. 800 x 800 or 600 x 600 mm. (LJ version: not on door side)

** Height of LJ version – reduce 1440 mm

*** 400 mm over internal bottom (max. diameter 350 mm. Larger diameters are special)



NFSZ3000 Filter with screw conveyor

The NFSZ3000 filter with screw conveyor is designed for small and medium-sized air flows with large material concentration.

The medium/large particles are separated in the filter hopper (inlet section optional) and the air is afterwards distributed to the filter bags. The collected material is discharged through the screw conveyor.

The filter is typically used in situations requiring non-pressurised material discharge directly into a silo, container or separate material transport system.

The filter can be supplied for either continuous operation or with a pause for cleaning of the filter bags every four hours.

- **Handles air flows from 5,000 – 60,000 m³/h (3,000 – 35,000 cfm)**
- **Available for positive or negative pressure operation**
- **Easy installation of pre-assembled top and hopper on site**
- **ATEX certified for St1 and St2 dust**
- **Wide range of screw conveyors for discharge**
- **Available in two widths, type E and J**



NFSZ3000 Filter with screw conveyor

Planning-in

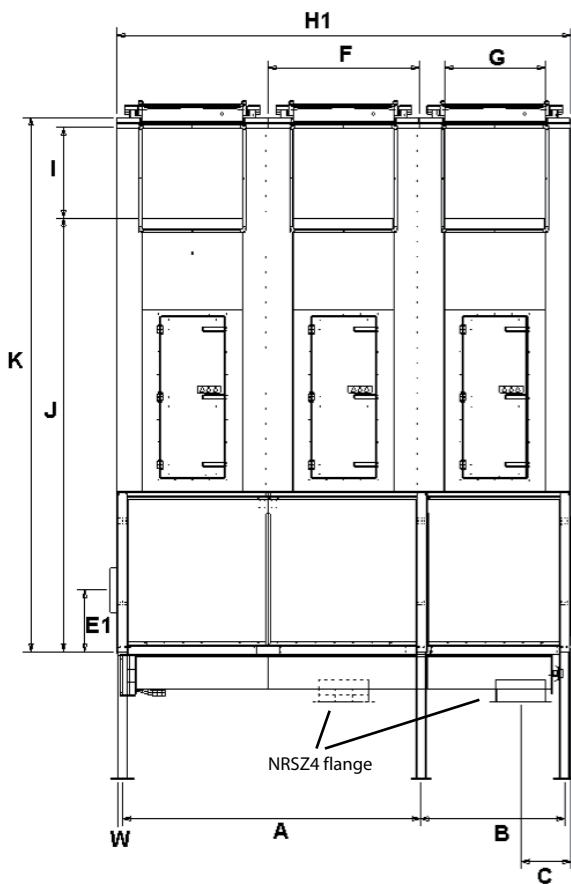

Example: NFSZ3000 3 HJ

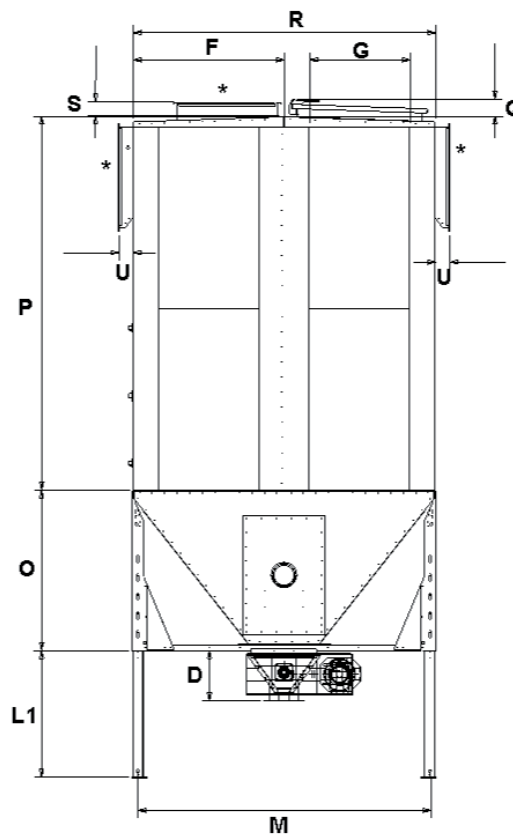

Type J (1200 x 2400 mm)

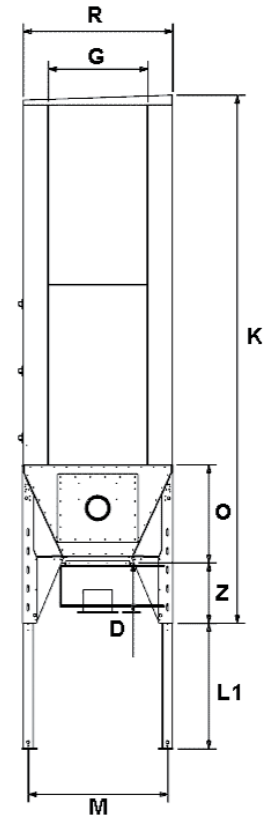

Type E (1200 x 1200 mm)

Type	A#	B	C	D	E1***	F	G	H1	I	J**	K**	L1	M	O	P**	Q	R	S	U	W	Z
E	2400	1106	393	400	485	1200	800	3600	720	2937	3737	See below	1121	780	2960	135	1200	115	115	47	480
J	2400	1106	393	400	485	1200	800	3600	720	3420	4220	See below	2321	1260	2960	135	2400	115	115	47	

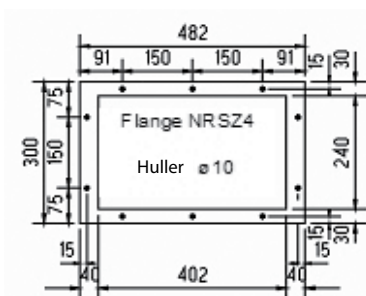

L1 – telescopic filter legs

Type	Min. Adjust.	Max. Adjust.
L = 1196 mm	155	850
L = 1596 mm	555	1250
L = 2195 mm	1155	1850
L = 2596 mm	1555	2250

No. of modules	H1	No. of modules	H1
1 HJ & LJ	1200	1 HE & LE	1200
2 HJ & LJ	2400	2 HE & LE	2400
3 HJ & LJ	3600	3 HE & LE	3600
4 HJ & LJ	4800	4 HE & LE	4800
5 HJ & LJ	6000		
6 HJ & LJ	7200		

Optional 1200 mm

* Optional position of outlet /reg. fan. 800 x 800 or 600 x 600 mm. (LJ version: not on door side)

** Height of LJ version – reduce 1440 mm

*** 400 mm over internal bottom (max. diameter 350 mm. Larger diameters are special)



NFPZ3000 Filter with bins

The NFPZ3000 filter is designed for small air flows with limited material content. The extracted material is separated in the filter hopper and collected in metal bins.

- **Handles air flows from 1,500 – 33,000 m³/h (1,000 – 20,000 cfm)**
- **Available for positive or negative pressure operation**
- **Easy installation of pre-assembled top and hopper on site**
- **ATEX certified for St1 or St2 dust**
- **Available in two widths, type E or J**



NFPZ3000 Filter with bins

Planning-in

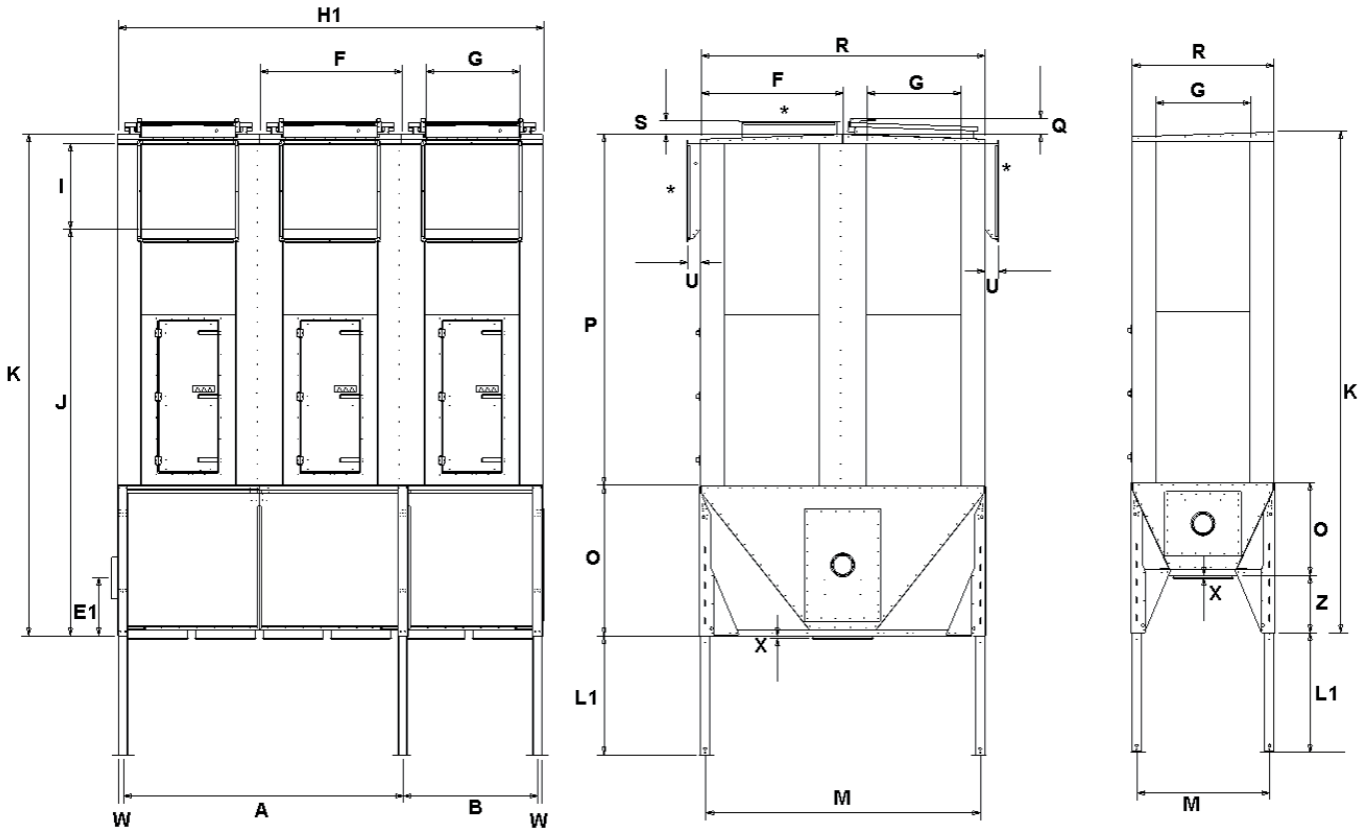

Example: NFPZ3000 3 HJ

Type J (1200 x 2400 mm)

Type E (1200 x 1200 mm)

Type	A#	B	E1***	F	G	H1	I	J**	K**	L1	N	O	P**	Q	R	S	U	W	X	Z
E	2400	1106	485	1200	800	3600	720	2937	3737	See below	1121	780	2960	131	1200	115	150	47	23	480
J	2400	1106	485	1200	800	3600	720	3420	4220	See below	2321	1260	2960	131	2400	115	150	47	23	

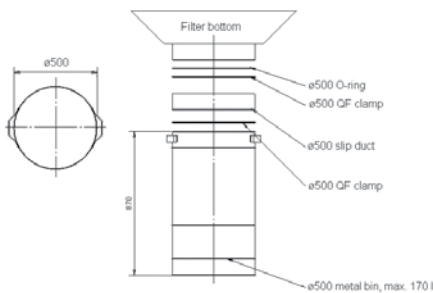

L1 – telescopic filter legs

Type	Min. Adjust.	Max. Adjust.
L = 1196 mm	155	850
L = 1596 mm	555	1250
L = 2195 mm	1155	1850
L = 2596 mm	1555	2250

No. of modules	H1	No. of modules	H1
1 HJ & LJ	1200	1 HE & LE	1200
2 HJ & LJ	2400	2 HE & LE	2400
3 HJ & LJ	3600	3 HE & LE	3600
4 HJ & LJ	4800	4 HE & LE	4800

Optional 1200 mm

* Optional position of outlet / reg. fan. 800 x 800 or 600 x 600 mm. (L version: not on door side)

** Height of L version – reduce 1440 mm

*** 400 mm over internal bottom (max. diameter 350 mm. Larger diameters are special)



NFKZ3000 Filter with UP venting

Regeneration fans and explosion relief doors

Each module of the NFZ3000 filter may be fitted with inspection door(s), explosion relief door(s) and regeneration fan(s).

As standard the filter is fitted with side venting due to the combined inspection and explosion relief door. Regeneration fan for cleaning the filter is as standard mounted on the roof of the filter.

Optional the filter can be fitted with top venting or venting type UP and regeneration fans on the side.



- **One explosion relief door per module for St1 dust**
- **Two explosion relief doors per module for St2 dust**
- **Regeneration fans on top or side**
- **Combined inspection and explosions relief doors as standard**
- **Top venting (optional)**
- **UP venting (optional)**

Positioning of regeneration fans and explosion relief doors

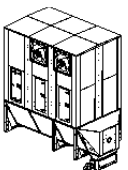
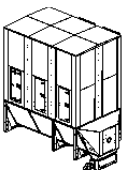
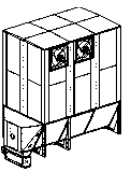
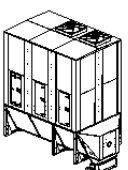
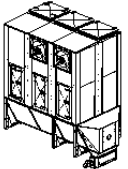
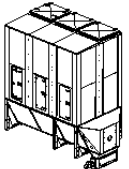
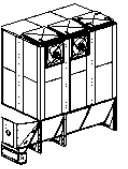
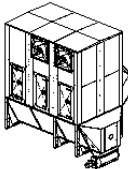
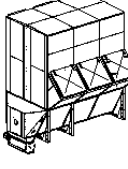
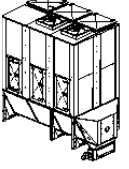
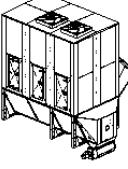
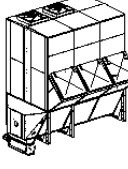
St1 dust

<p>A</p>  <p>Ex. doors and regeneration fans at same side (not L type).</p>	<p>B1</p>  <p>Ex. doors and regeneration fans opposite each other.</p>	<p>B2</p>  <p>Ex. doors and regeneration fans opposite each other.</p>	<p>C</p>  <p>Ex. doors left or right. Regeneration fans in top.</p>
<p>D</p>  <p>Locked doors (only for inspection). Regeneration fans at same side. Top venting (not L type).</p>	<p>E1</p>  <p>Locked doors (only for inspection). Regeneration fans opposite the doors. Top venting.</p>	<p>E2</p>  <p>Locked doors (only for inspection). Regeneration fans opposite the doors. Top venting.</p>	<p>F1</p>  <p>Locked doors (only for inspection). Regeneration fans at same side. Venting type UP (not L type).</p>
<p>F2</p>  <p>Locked doors (only for inspection). Regeneration fans at same side. Venting type UP (not L type).</p>	<p>G</p>  <p>Locked doors left or right (only for inspection). Regeneration fans on top. Top venting.</p>	<p>H1</p>  <p>Locked doors (only for inspection). Venting type UP opposite the doors. Regeneration fans on top.</p>	<p>H2</p>  <p>Locked doors (only for inspection). Venting type UP opposite the doors. Regeneration fans on top.</p>

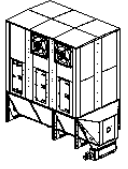
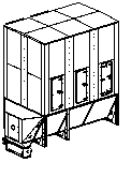
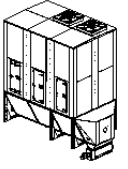
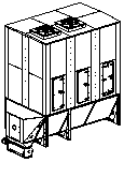
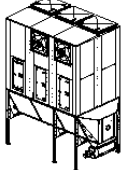
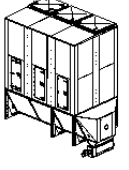
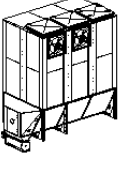
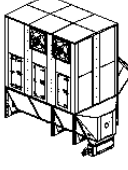
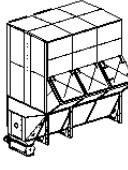
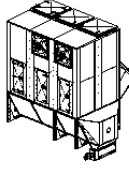
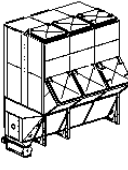
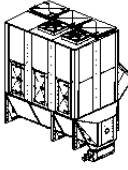
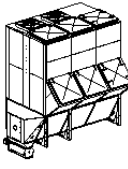
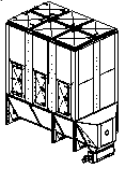
St2 dust

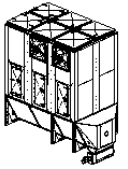
<p>I1</p>  <p>Ex. doors at both sides. Regeneration fans left or right (not L type).</p>	<p>I2</p>  <p>Ex. doors at both sides. Regeneration fans left or right (not L type).</p>	<p>J1</p>  <p>Ex. doors at both sides. Regeneration fans on top.</p>	<p>J2</p>  <p>Ex. doors at both sides. Regeneration fans on top.</p>
<p>K</p>  <p>Ex. doors and regeneration fans at same side. Top venting (not L type).</p>	<p>L1</p>  <p>Ex. doors and regeneration fans opposite each other. Top venting.</p>	<p>L2</p>  <p>Ex. doors and regeneration fans opposite each other. Top venting.</p>	<p>M1</p>  <p>Ex. doors and regeneration fans at same side. Venting type UP. (not L type).</p>
<p>M2</p>  <p>Ex. doors and regeneration fans at same side. Venting type UP (not L type).</p>	<p>N1</p>  <p>Doors locked (only for inspection). Regeneration fans at same side. Venting type UP and top venting (not L type).</p>	<p>N2</p>  <p>Doors locked (only for inspection). Regeneration fans at same side. Venting type UP and top venting (not L type).</p>	<p>O1</p>  <p>Doors locked (only for inspection). Regeneration fans on top. Venting type UP and top venting.</p>
<p>O2</p>  <p>Doors locked (only for inspection). Regeneration fans on top. Venting type UP and top venting.</p>	<p>P1</p>  <p>Doors locked (only for inspection). Regeneration fans opposite the locked doors. Top venting.</p>	<p>P2</p>  <p>Doors locked (only for inspection). Regeneration fans opposite the locked doors. Top venting.</p>	<p>Q</p>  <p>Doors locked (only for inspection). Regeneration fans at same side. Top venting (not L type).</p>

NOTE: 1 - Left side view
2 - Right side view

Superbag filter material



The heart of the system

A filter is only as good as the filter bags it uses. This is the component that provides the filtering while allowing clean air to pass through with the least possible resistance and, therefore, the lowest possible consumption of energy – even after several thousand hours of operation.

Efficiency and low energy consumption

Superbag is Nederman's own polyester filter bag. A patented weaving technique in tubular format gives the filter bag a surface which can cope with varying dust loads and with virtually any type of dust. Better filtering efficiency is achieved with this unique filter media which provides low pressure drop, and low energy consumption.

Strength and durability

The special shape of the SUPERBAG helps to ensure that the high efficiency and effectiveness of the NFZ3000 filter system is maintained even after long periods of operation. The durability is the result of the patented construction, strong polyester fibre and seamless body. These features also make cleaning of the filter bag very easy.

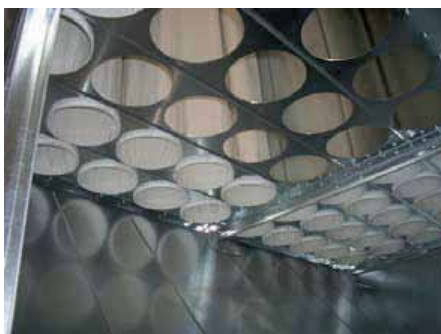

Antistatic

SUPERBAG's interwoven carbon fibre wire provides higher anti-static properties – both on the surface and inside – than traditional filter bags. This reduces the risk of fire and explosion as fine particles are removed.

Regeneration fan

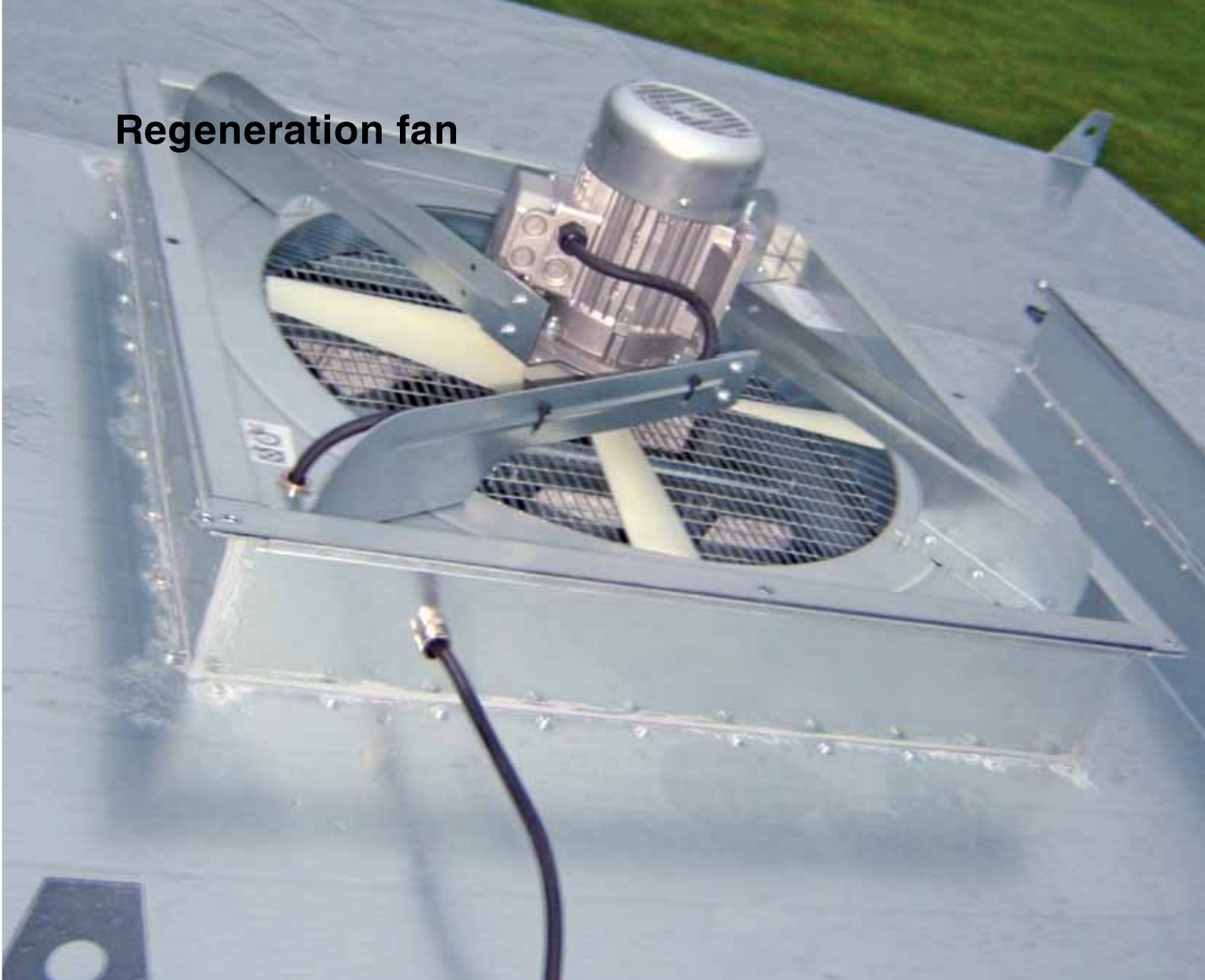

The regeneration fan for reverse air cleaning of the NFZ3000 filter operates at time intervals dependant on filter load and dust level. The regeneration fan can be mounted either in the roof or on the side of the filter.

The fan is an axial type fan (800 x 800 mm). The regeneration fan is available in a 1.1 kW and a 2.2 kW version.

The regeneration fan is designed for high pressure in the working mode and low air resistance in the stop mode.

The regeneration fan is braked in the stop mode, minimizing noise.

The pressure resistance is 100 Pa at 10,000 m³/h.

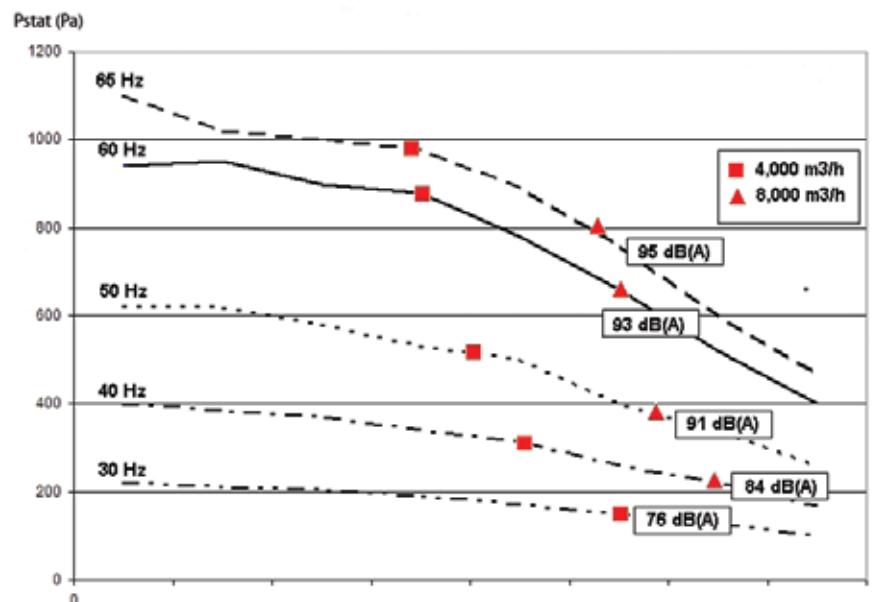

Rotary valves

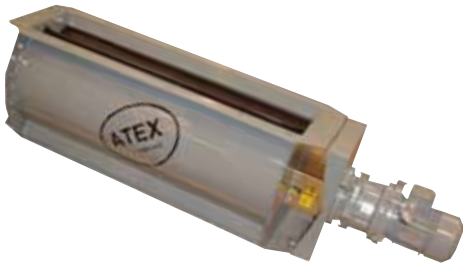

required from the filter or cyclone to the silo or conveying system, at atmospheric pressure. This is an ideal application for the NRSZ type rotary valve.

- **The rotary valve is a barrier against spreading of an explosion**
- **Simple design and proven strength**
- **Available in different lengths and capacities**

The NRSZ type rotary valve is used to transfer material between two separate systems. In pneumatic conveying systems, discharge is usually

The rotary valve can be used for most material types, also explosive (St1 or St2), though the particle size must not exceed 13 x 13 x 13 mm.

NRSZ 4

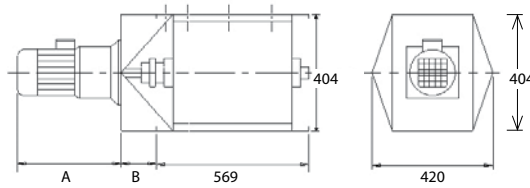
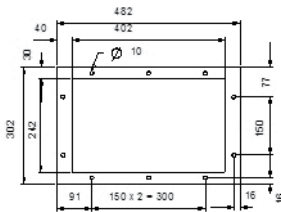

Motor kW	A	B
0.18	651	115
0.75	430	68

Both NRSZ 4 and NRSZ 10

NRSZ 10

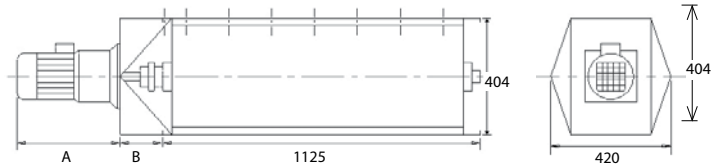
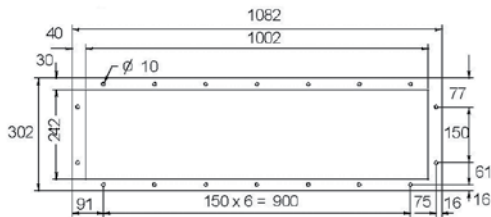

NRSZ 20

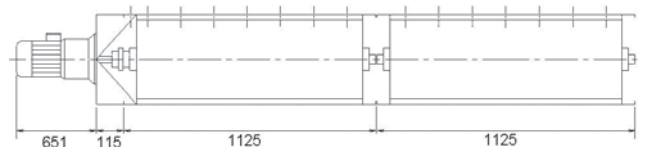
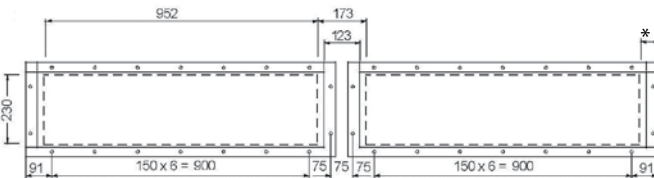

NRSZ 30

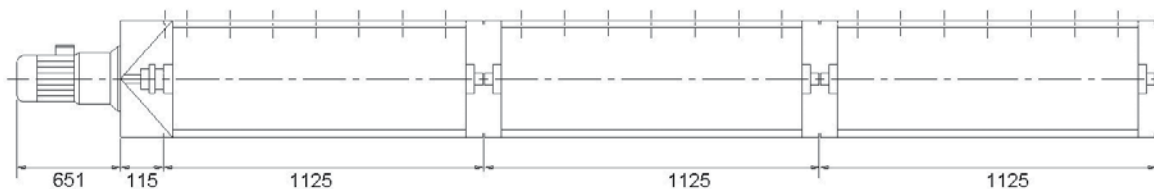

CARZ Back pressure flap valve

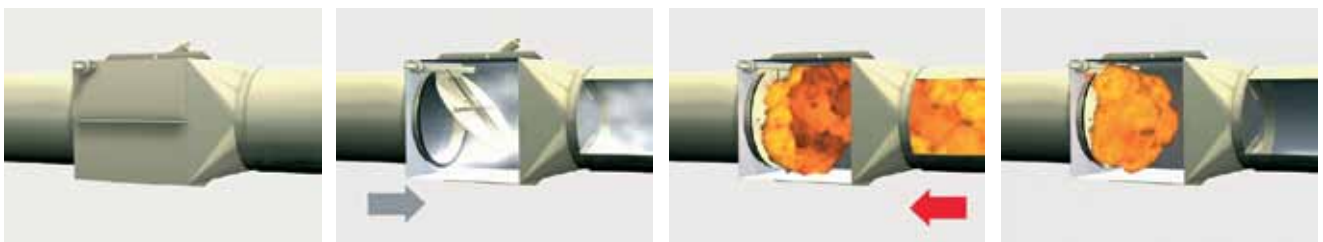

Suction direction.

Explosion direction.

The back pressure flap type CARZ is designed to prevent the effects of a pressure wave and flame front, arising from an explosion downstream, from travelling back along the duct into which it is fitted.

The CARZ back pressure flap is effective up to a maximum declared reduced explosion pressure within the protected enclosure (typically ATEX zone 20 internally) and acts as an isolating valve during the explosion event.

In normal operating mode it is held open against gravity by the dust laden air stream flowing in the direction opposite to that of the explosion pressure wave.

Minimum 2 metres straight duct are required before the CARZ back pressure flap to fulfill ATEX. For dimensions 560-1000, minimum 5 metres straight duct are required.

- **ATEX certified for St1 dust**
- **Available in all dimensions from $\varnothing 160$ to $\varnothing 1000$**
- **Prevents unwanted effects of an explosion from spreading**
- **Prevents stray dust returning along the duct when operation is stopped**
- **Simple and robust design**

ATEX
COMPLIANT



ATEX

Typical wood application

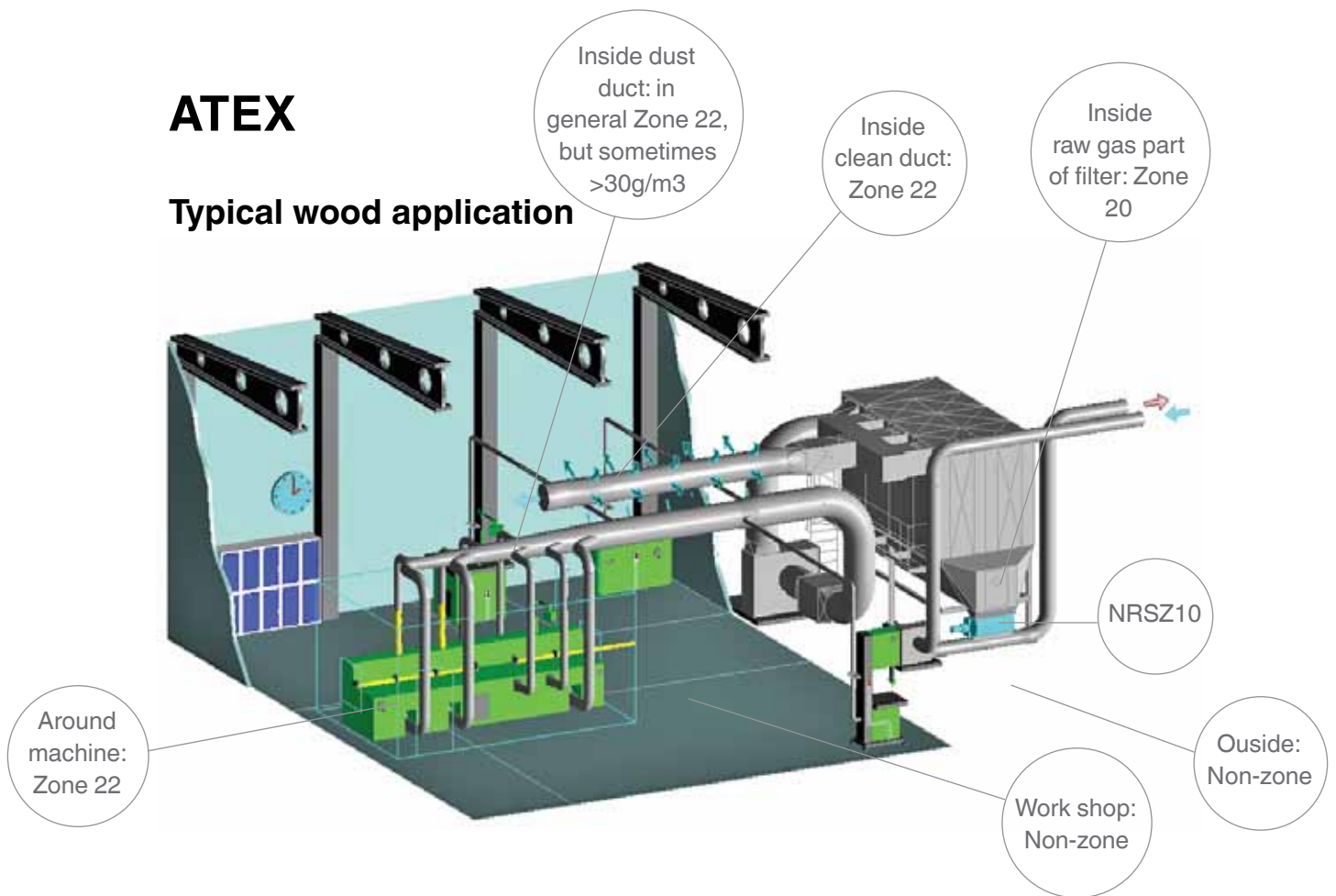

Nederman can supply ATEX compliant components such as filter units and fans; ATEX certified protective systems such as rotary valves, explosion relief doors, and back pressure flaps are also available according to ATEX directive 94/9/EC.

A dust extraction system from Nederman fulfills the ATEX demands:

- The explosion strength of the filter has been proven
- The pressure in the filter is controlled by explosion relief doors or panels. These components are ATEX approved
- The risk of an explosion spreading has to be prevented by installing safety equipment such as rotary valves, back pressure flaps, etc. Nederman can supply these components
- Fans, etc. are certified when handling potentially explosive dust

ATEX Directive 99/92/EC

Since 1st July 2003 any new equipment installed for use with potentially explosive dusts or in a zoned area must be ATEX certified.

Since 1st July 2006 any existing equipment handling potentially explosive dusts or in a zoned area must be Risk Assessed.



NFZ3000 Filter applications



Specifications

NFSZ3000 3 HJ Filter with screw conveyor in vacuum version

Air flow 18,000 m³/h

Manufacturing of wood packaging



Specifications

NFSZ3000 2 HE Filter with screw conveyor in overpressure version

Air flow: 5,000 m³/h

Woodworking



Specifications

NFKZ3000 5+1 HJ Filter with chain conveyor

Air flow: 50,000 m³/h

Furniture manufacturing



Nederman-
Your supplier of dust extraction systems



The Nederman Group is one of the world's leading suppliers of products and solutions within the environmental technology sector, focusing on industrial air filtration and recycling.

Nederman products and solutions contribute to reducing the environmental impact from industrial production processes and to creating a safe and clean working environment whilst boosting production efficiency.

The Group's offering covers everything from the design stage through to installation, commissioning and servicing.

Nederman has subsidiaries in 29 countries and agents and distributors in over 30 countries.

Nederman is ISO 9001 and 14001 certified. The Group develops and produces in its own manufacturing and assembly units in Europe, North America and Asia.

In 2010 Nederman acquired Dantherm Filtration, thereby forming the world's leading Group within industrial air filtration.

The Group is listed on Nasdaq OMX Stockholm; it has about 1400 employees and a turnover of about 2 billion SEK

Nederman
www.nederman.com

Nederman Sales companies in: Australia, Austria, Belgium, Brazil, Canada, China, Czech Rep. Denmark, France, Germany, Hungary, India, Indonesia, Ireland, Malaysia, Northern Ireland, Norway, Poland, Portugal, Romania, Russia, Slovak Republic, Spain, Sweden, Turkey, United Kingdom, USA, Thailand, Vietnam.

Nederman Agents in: Bulgaria, Cyprus, Egypt, Estonia, Finland, Greece, Holland, Hongkong, Iceland, Iran, Ireland, Italy, Japan, Korea, Latvia, Lithuania, Malaysia, New Zealand, Philippines, Saudi Arabia, Serbia, Singapore, Slovenia, South Africa, Switzerland, Taiwan R.O.C, Thailand, Turkey, United Arab Emirates