

Compact dust collectors

FlexPAK DX

DX Models

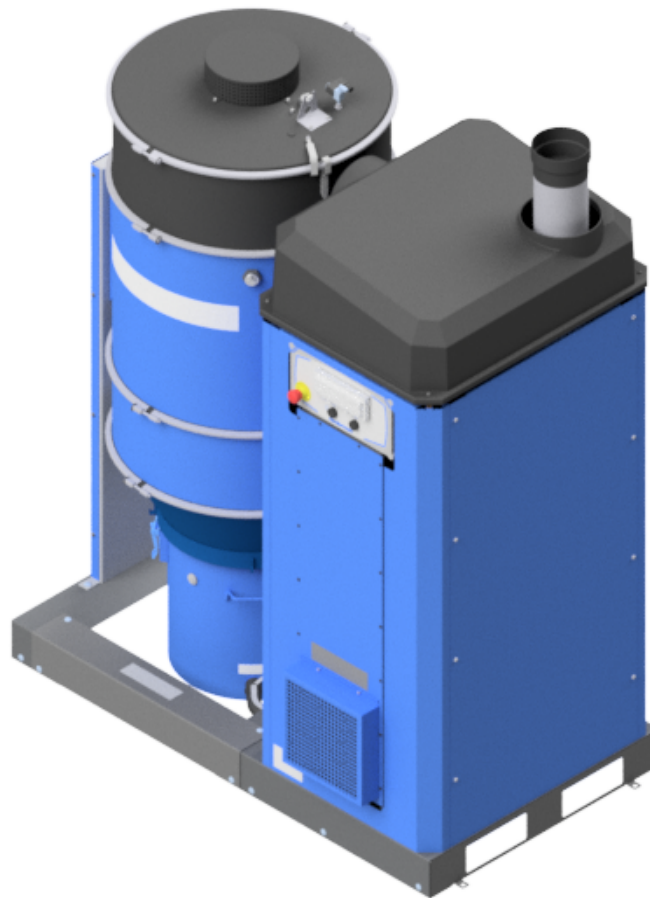

Original installation and service manual

EN INSTALLATION AND SERVICE MANUAL

Table of contents

Figures	5
1 Preface	15
2 Safety	15
2.1 Classification of important information	15
3 Description	15
3.1 Function	15
3.1.1 Filtration in two stages	15
3.1.2 Automatic filter cleaning	15
3.1.3 Control filter	15
3.2 FlexPAK DX and ATEX	15
3.2.1 Permitted materials	16
3.3 Explosion protection	16
3.3.1 Explosion venting	16
3.3.2 Explosion suppression system	16
3.3.3 Flameless venting	17
3.3.4 Isolation device	17
3.4 Dimensions	17
3.5 Technical data	18
3.6 Fuses	19
3.7 Main components	19
3.8 Connections	19
3.9 Start and control unit	20
3.9.1 Start and control unit	20
3.10 Frequency converter	20
4 Accessories	20
5 Installation	20
5.1 Delivery check	21
5.2 Installation requirements	21
5.2.1 Bolts	21
5.3 Duct dimensions and installation	21
5.3.1 Requirements	21
5.3.2 Recommendations	21
5.4 Installing the unit	22
5.4.1 Indoor installation	22
5.4.2 Outdoor installation	22
5.4.3 Moving the unit	22
5.5 Electrical installation	22
5.6 Suppression system installation	23
5.7 General requirements	23
5.8 Automatic bin emptying function	23
5.9 Machining chips and swarf extraction	23
5.10 Pneumatic filter cleaning valve	23
5.11 ATEX Duct Isolation Valve	23
5.12 Ground check measurement	23
5.13 Vacuum setpoint	24
5.14 Rotary valve	24
5.15 Compressed air installation	24
5.15.1 Requirements	24
5.15.2 Installation	24
6 Maintenance	24
6.1 Service and maintenance of ATEX equipment	24
6.2 Checks one month after installation and every year	25

6.3	Empty the collector bin	25
6.4	Replace the main filter	25
6.5	Change control filter	26
6.6	Check the filter cleaning function	26
6.7	The motor and the fan unit	26
6.8	Cooling filter for the frequency converter	26
6.9	Loading new software	26
6.9.1	Frequency converter control panel	26
6.9.2	Firmware and software labelling	26
6.9.3	Upgrading the system	27
6.10	Spare Parts	27
6.10.1	Ordering spare parts	27
6.11	Recycling	27
6.11.1	Environmental information	27
7	Troubleshooting	28
7.1	Tools	28
7.2	Remove the lid of the start and control unit	28
8	Acronyms and abbreviations	30
9	Appendix A: Installation protocol	32
10	Appendix B: Service protocol	34

Figures

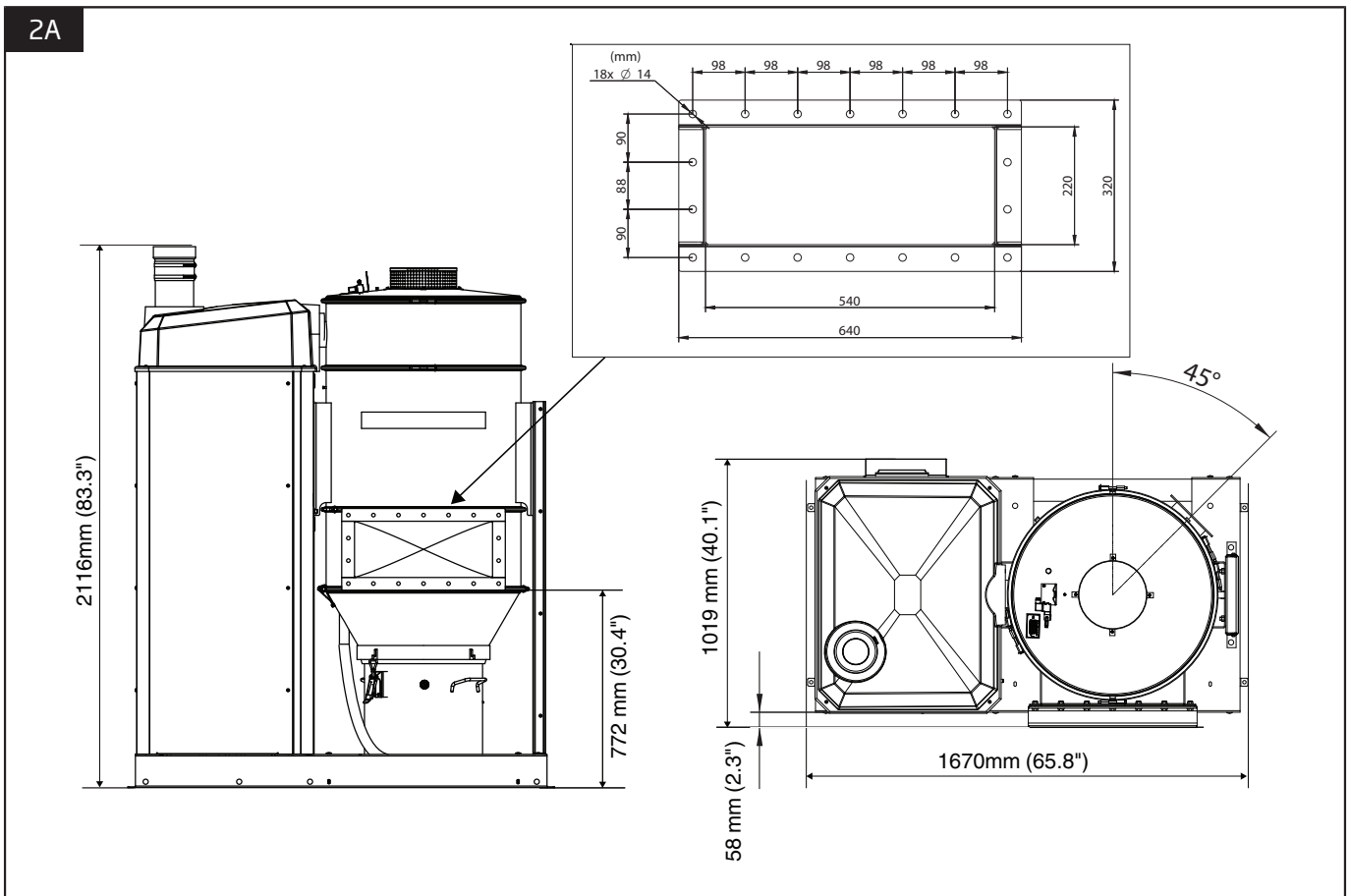
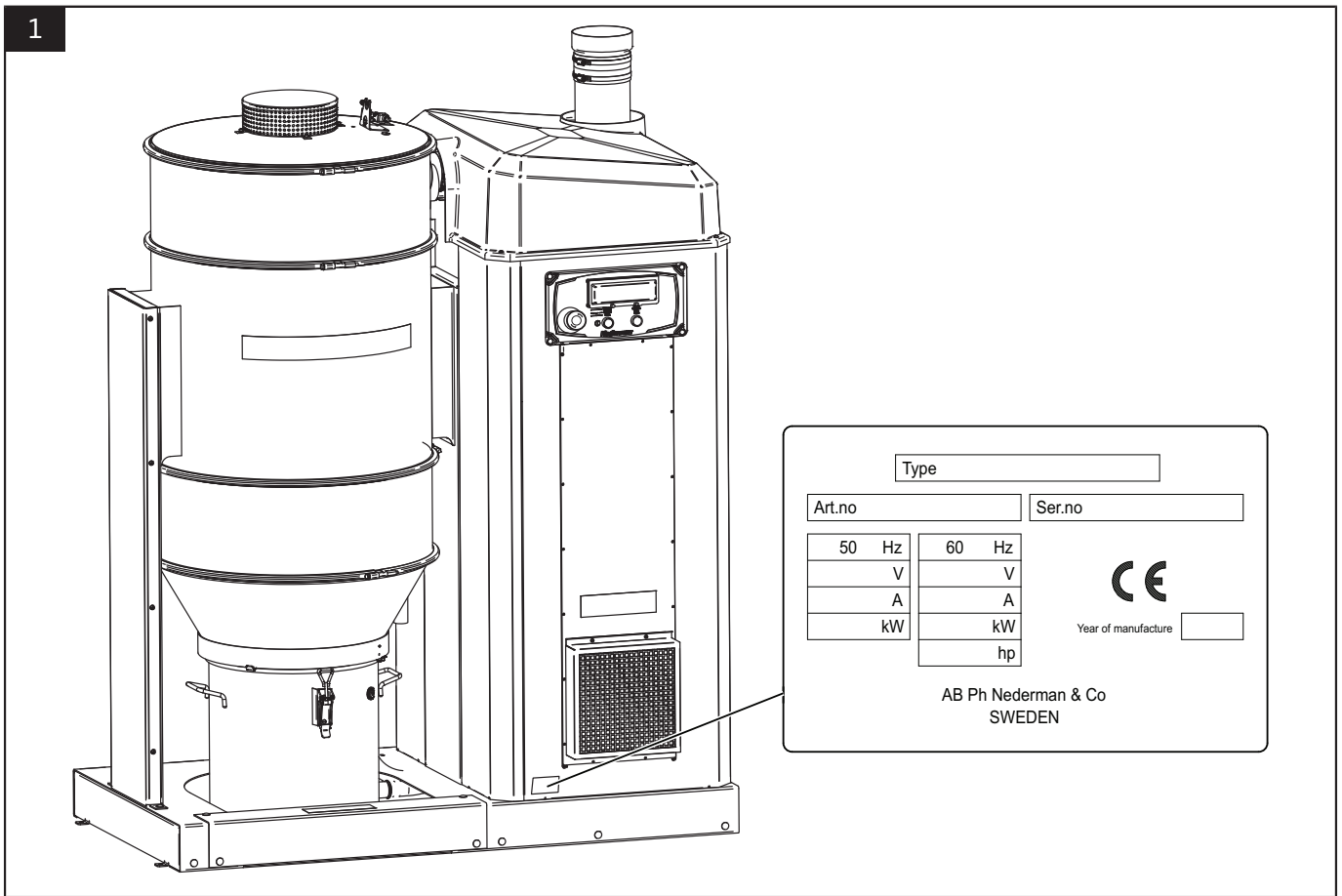

2B

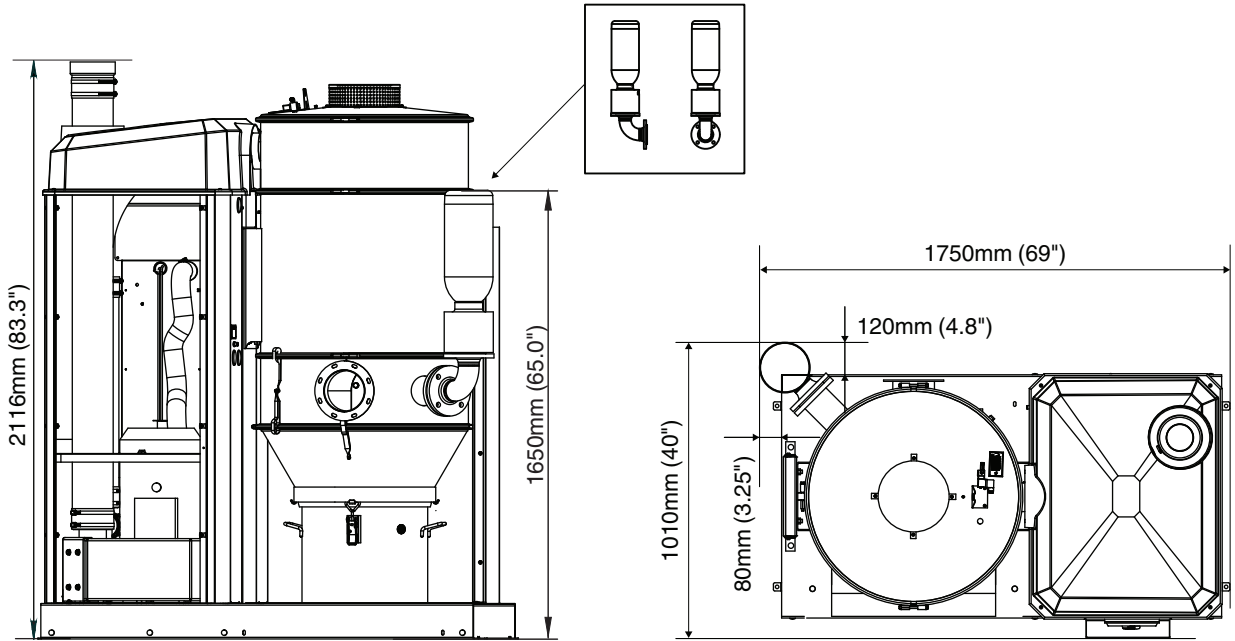

2C

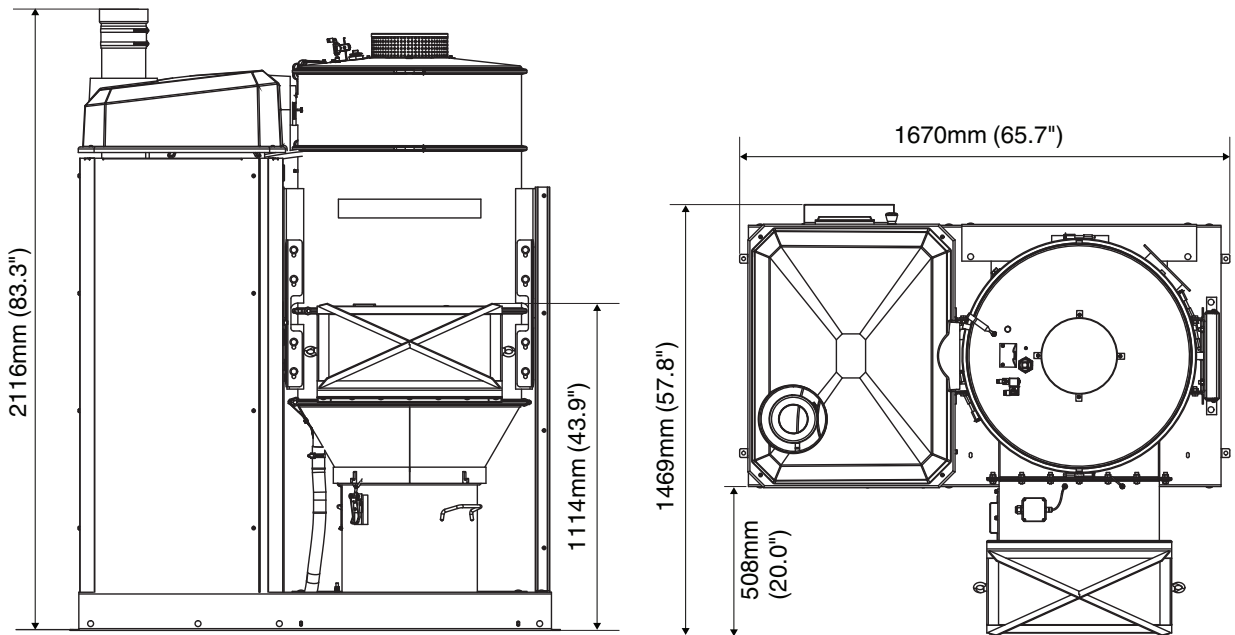

3A

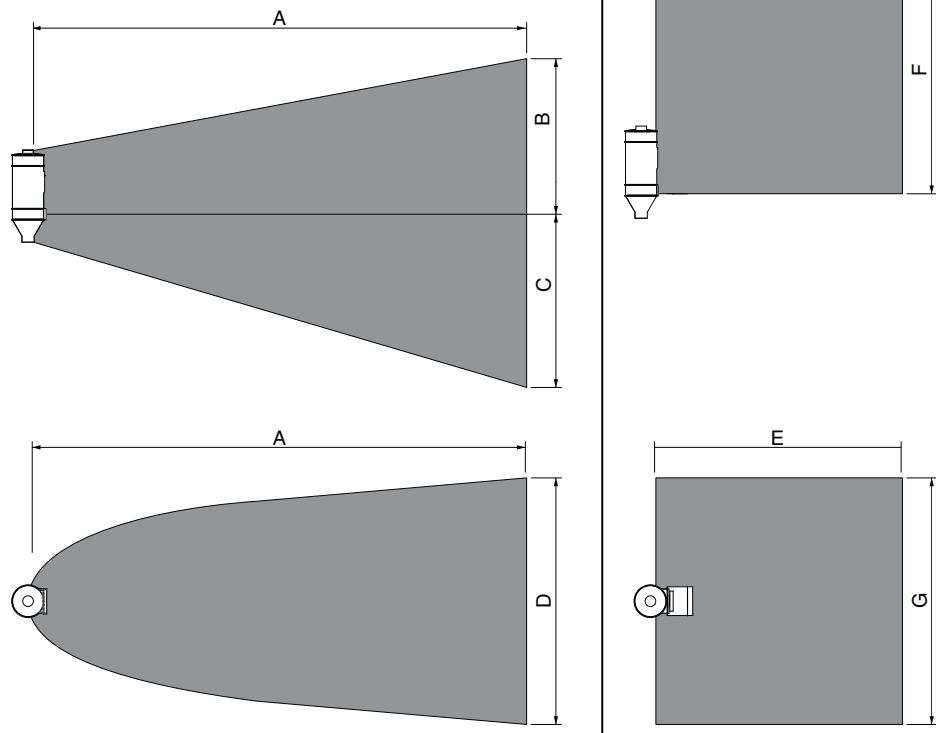

3B

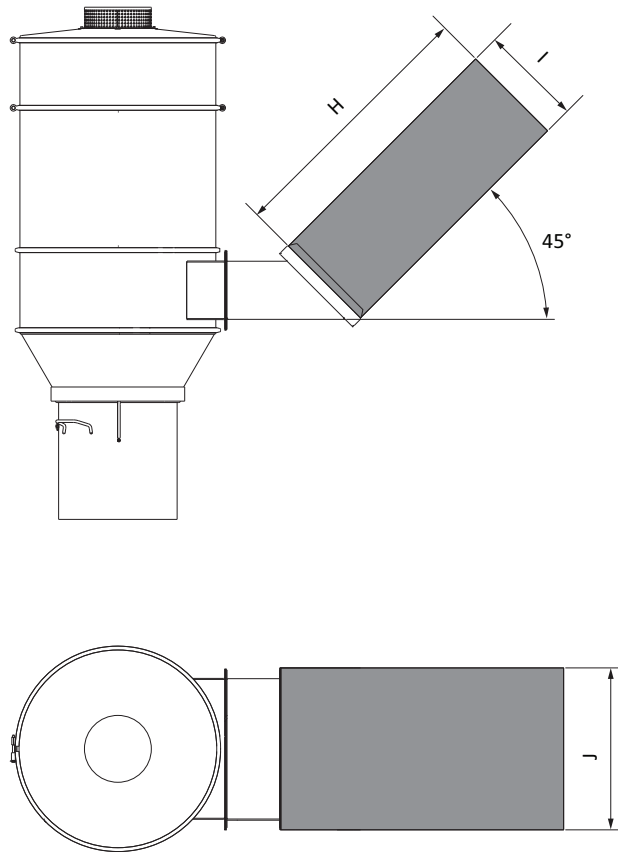

4A

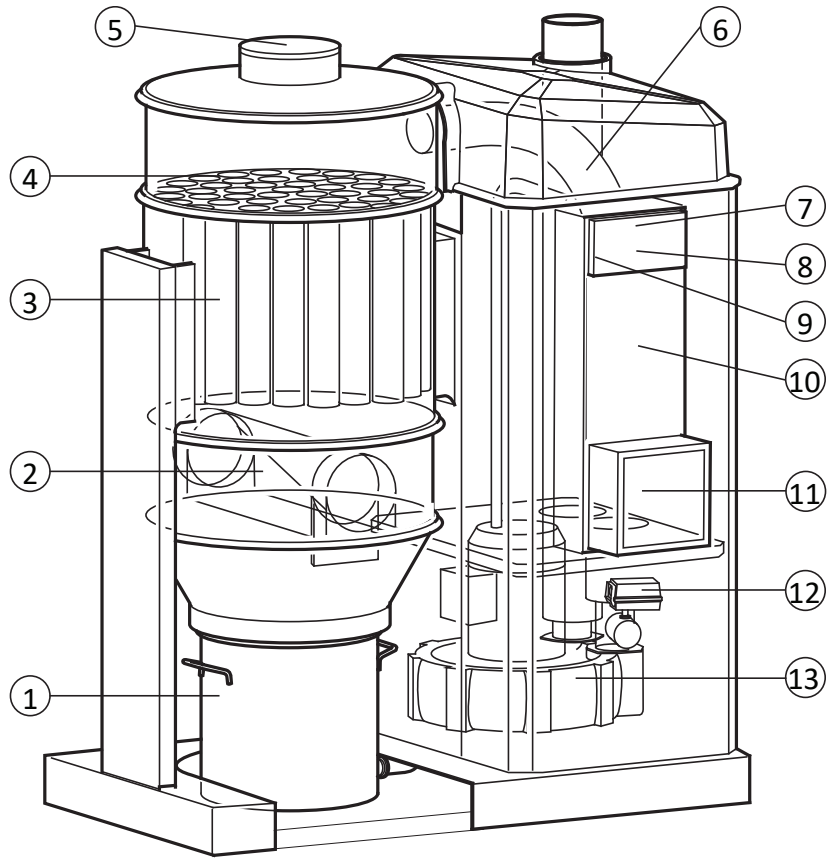

4B

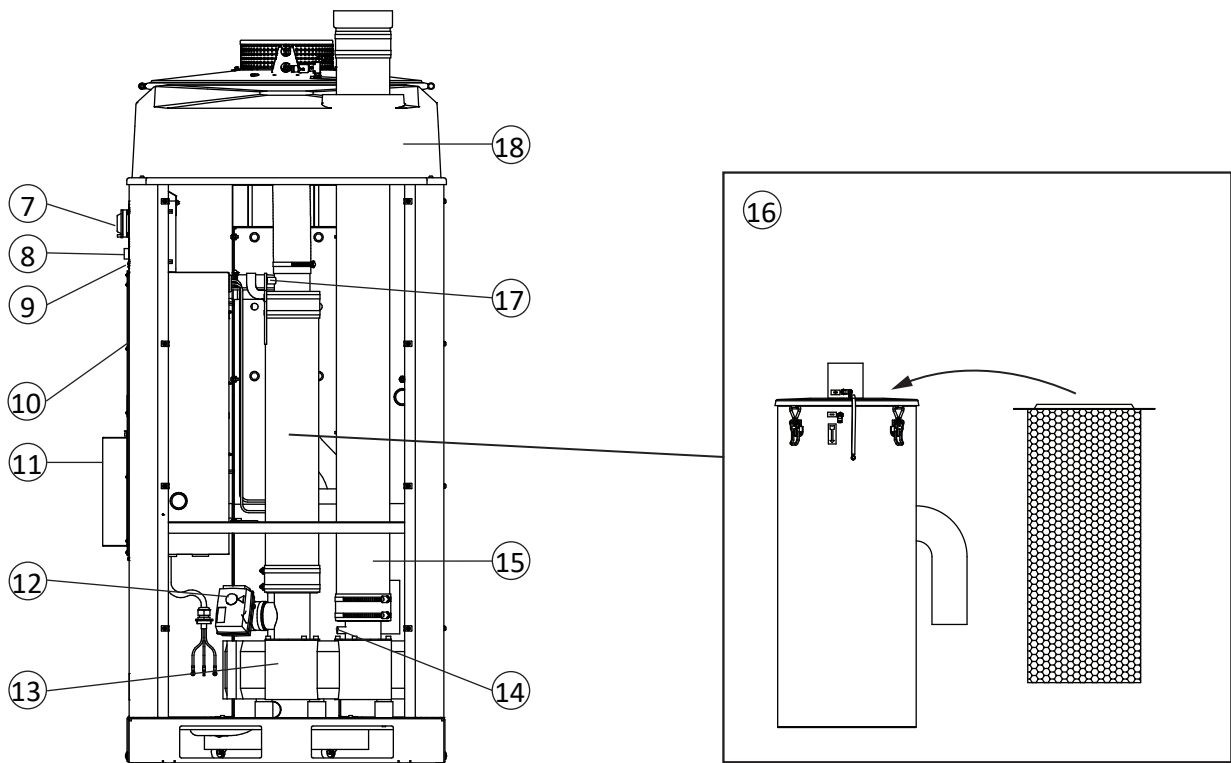

4C

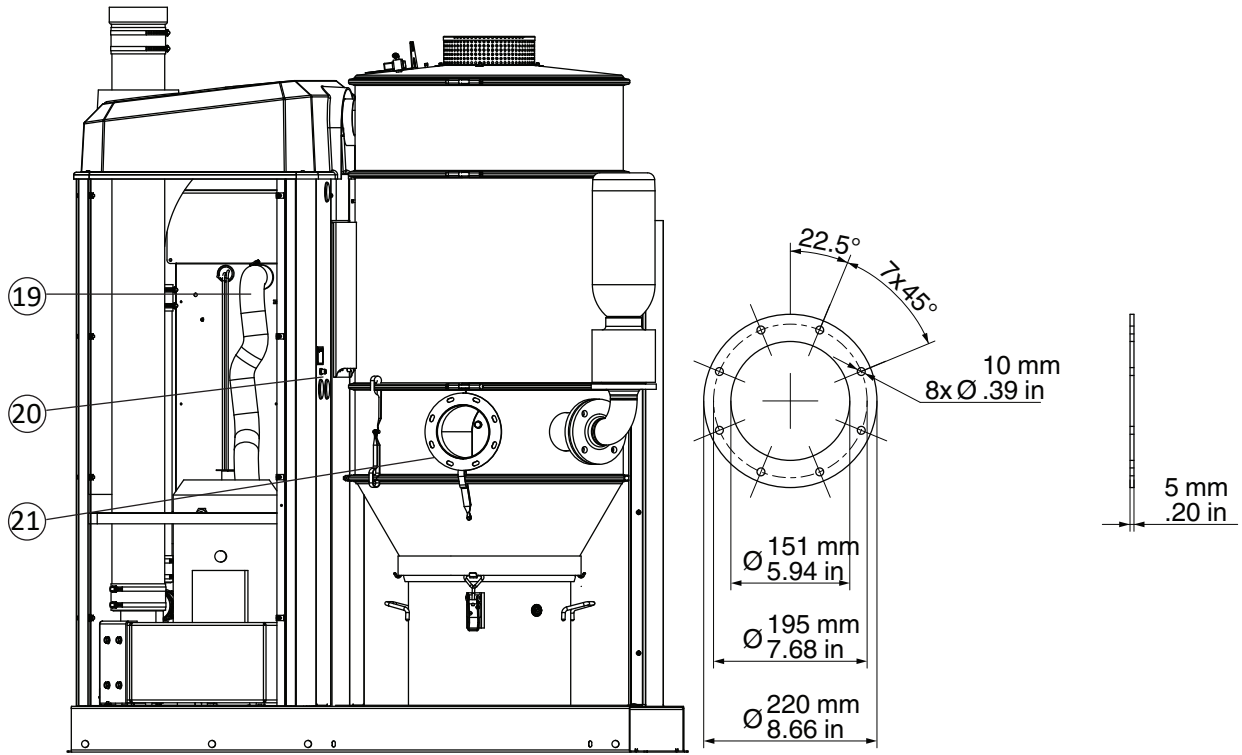

5

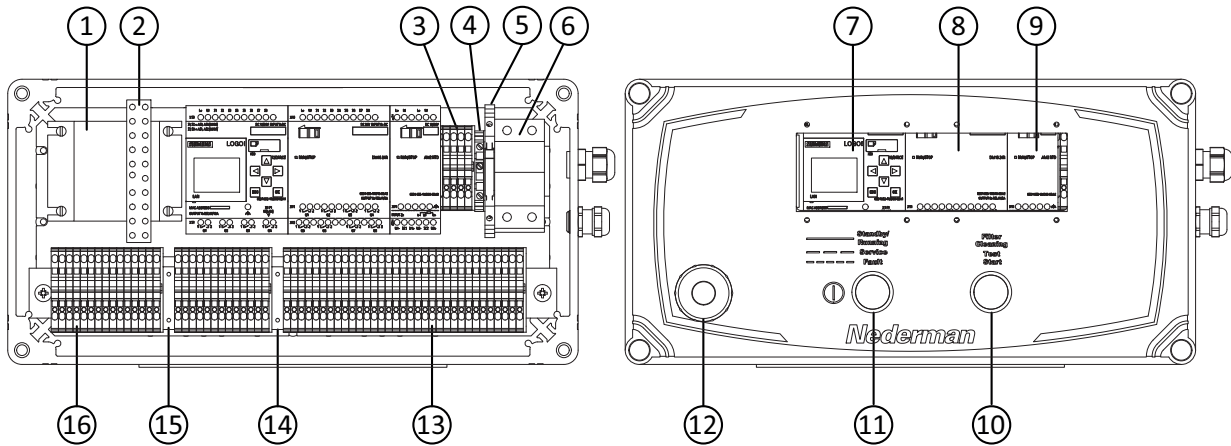

6

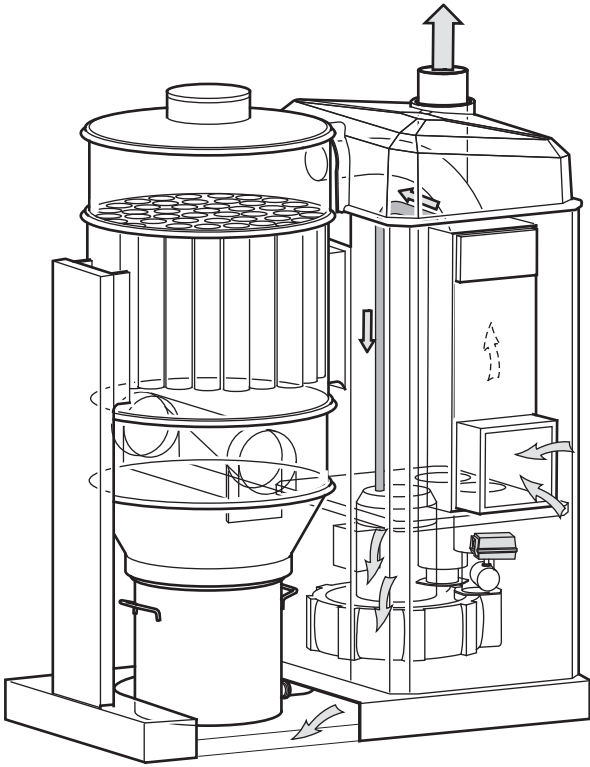

7

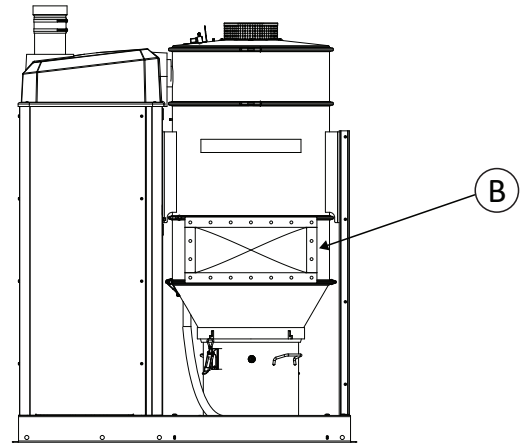
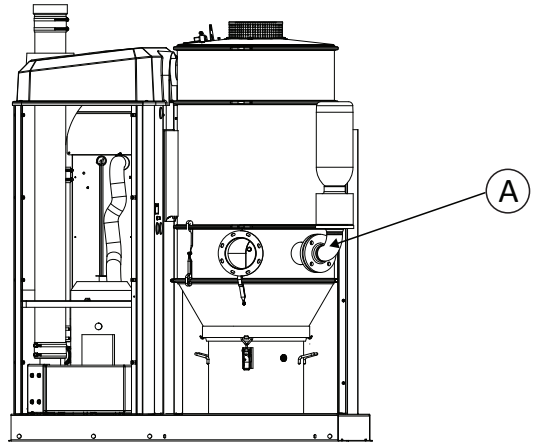

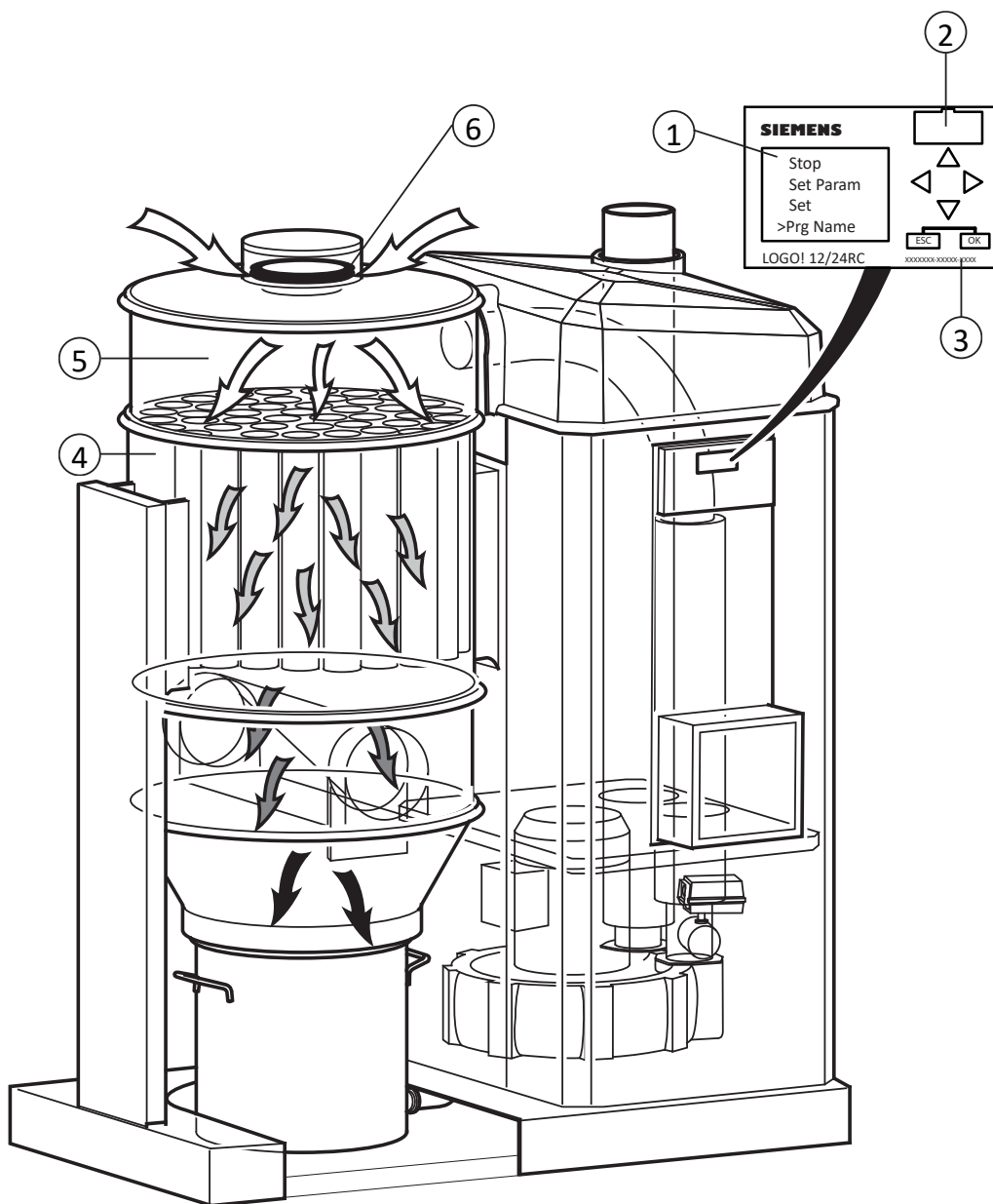
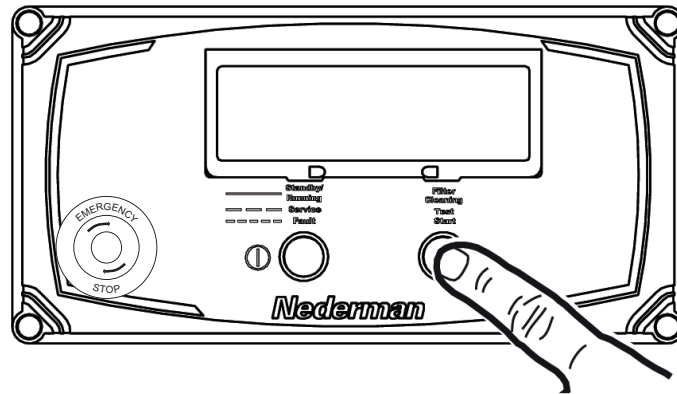

9

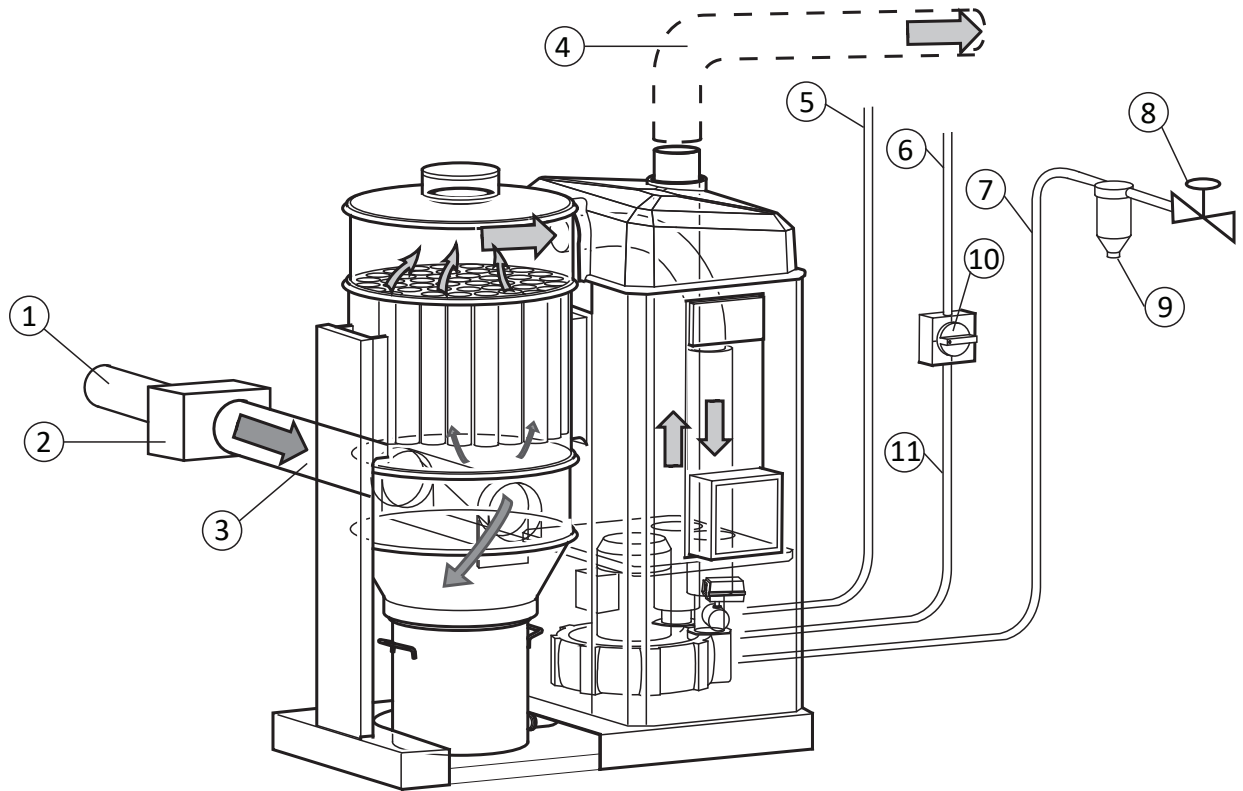

10

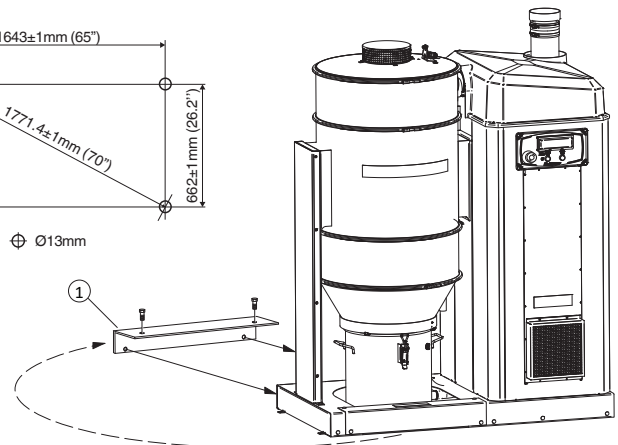
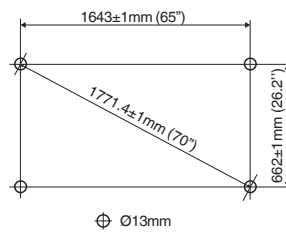
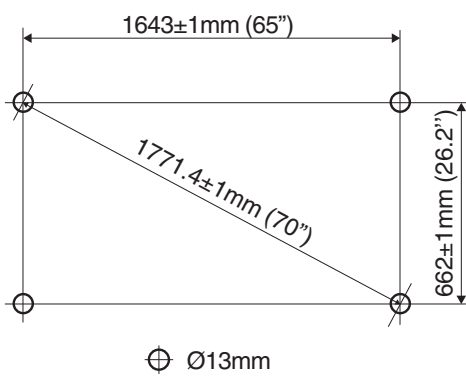

11

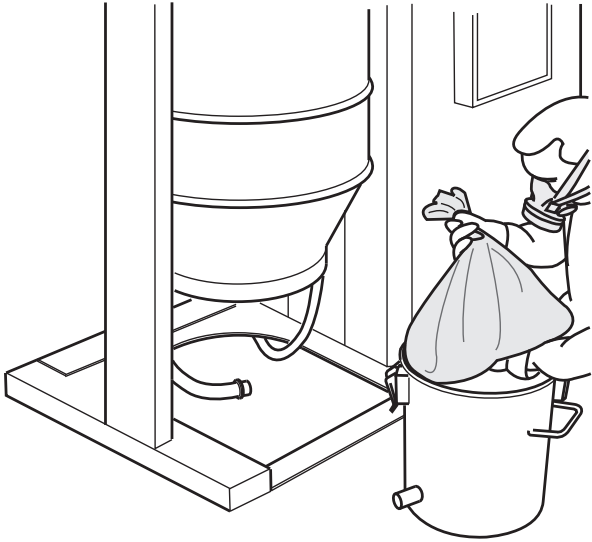

12



13



14

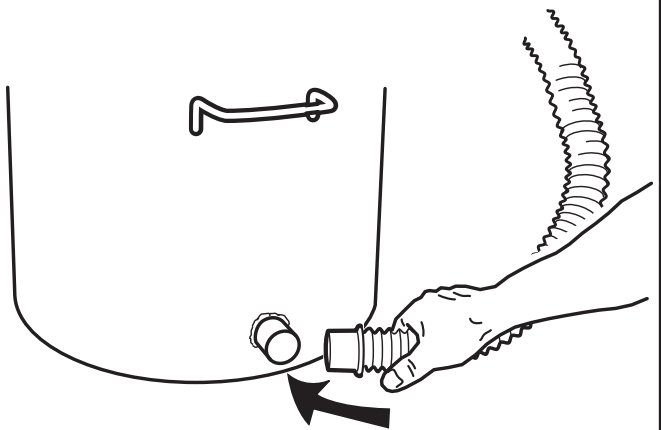

15

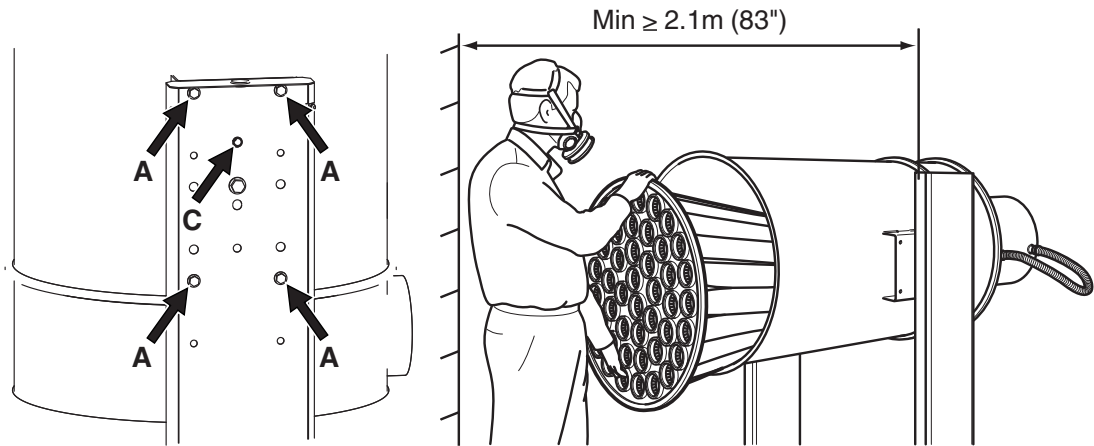

16

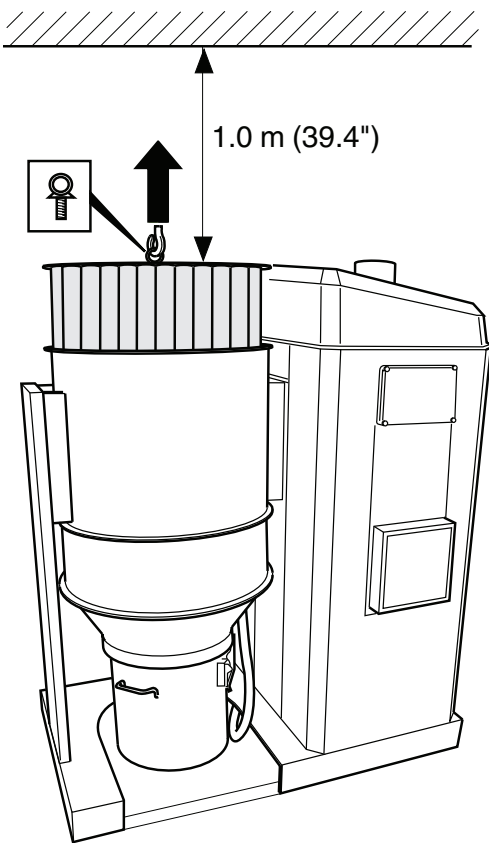

17

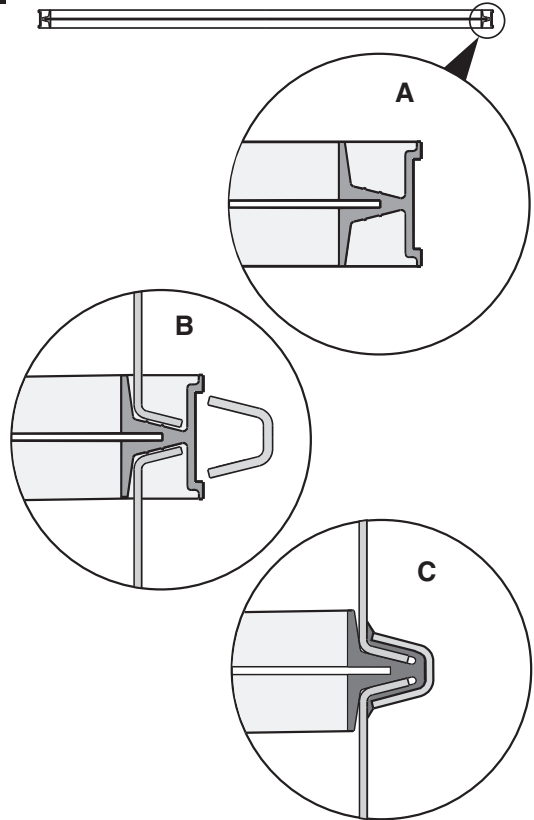

1 Preface

Thank you for using a Nederman product!

The Nederman Group is a world-leading supplier and developer of products and solutions for the environmental technology sector. Our innovative products will filter, clean and recycle in the most demanding of environments. Nederman's products and solutions will help you improve your productivity, reduce costs and also reduce the impact on the environment from industrial processes.

Read all product documentation and the product identification plate carefully before installation, use, and service of this product. Replace documentation immediately if lost. Nederman reserves the right, without previous notice, to modify and improve its products including documentation.

This product is designed to meet the requirements of relevant EC directives. To maintain this status, all installation, maintenance, and repair is to be done by qualified personnel using only Nederman original spare parts and accessories. Contact the nearest authorized distributor or Nederman for advice on technical service and obtaining spare parts. If there are any damaged or missing parts when the product is delivered, notify the carrier and the local Nederman representative immediately.

This manual is supplemented by:

- User Manual
- PLC Settings Manual
- Electrical wiring diagrams

2 Safety

2.1 Classification of important information

This document contains important information that is presented either as a warning, caution or note, according to the following examples:



WARNING! Risk of personal injury

Warnings indicate a potential hazard to the health and safety of personnel, and how that hazard may be avoided.



CAUTION! Risk of equipment damage

Cautions indicate a potential hazard to the product but not to personnel, and how that hazard may be avoided.



Notes contain other information that is important for personnel.

3 Description

3.1 Function

FlexPAK DX is a complete vacuum unit with a direct driven side channel fan fitted as one unit on a steel frame and a start and control unit with an integrated 24 V transformer. The unit is controlled by a frequency converter, has automatic start/stop, and automatic filter cleaning.

3.1.1 Filtration in two stages

FlexPAK DX filters particles in two stages. In the first stage, coarse particles are separated away in the inlet. In the second stage, fine particles are separated away by filter bags, see [Figure 9](#).

3.1.2 Automatic filter cleaning

FlexPAK DX uses filter cleaning by a short blast of reversed airflow with atmospheric pressure. By the rapid opening of the Filter Cleaning Valve (FCV) located on top of the filter, a powerful blast of reversed airflow is created, efficiently dislodging dust from the filter bags, see [Figure 8](#).

3.1.3 Control filter

The unit is equipped with a control filter, see [Figure 4B](#), item 16. The control filter filters the air after the main filter to ensure that no material continues to the suction source in case of a main filter breakage. The control filter functions as a safety device and does not increase the filtration efficiency.

The pressure drop over the control filter is monitored, and a signal is sent to the control unit if the pressure difference reaches the set value. The pressure difference is preset at 4 kPa / 40 mbar / 0,58 psi.

3.2 FlexPAK DX and ATEX

FlexPAK DX is designed to extract combustible and noncombustible dust, but the unit "as a whole" is not to be placed in an area that is classified as a zone according to directive 1999/92/EC. It is only the inside of the filter that meets ATEX requirements.

FlexPAK DX may be used with duct systems internally classified as zone 20, 21 or 22.

The product has no  marking since there is no internal ignition source. The inside is to be considered a simple filter/silo and does not fall under the scope of the directive 2014/34/EU.¹

¹ Source: ATEX 2014/34/EU Guidelines § 243 Filter units and vented silo bins.

3.2.1 Permitted materials



WARNING! Explosion risk

- Do not collect material that may cause ignition or blocking. It is strictly prohibited to collect material that may undergo dangerous chemical or thermal reactions and/or self-ignite.
- Do not make any changes to this product without consulting Nederman. Adding a relief duct or changing the spacing or length of filter elements affects the calculations according to EN 14491.
- The filter should not be used for filtering fumes from welding processes.



WARNING! Risk of personal injury

Use suitable protective equipment: goggles, ear protection and a protective mask.



It is of the utmost importance to know the properties of the extracted material.



Some materials may undergo chemical reactions in combination with humidity/water. Such humidity may, for example, form if the humidity in the extracted air is condensed in the filter.

FlexPAK DX is intended to be a part of an extraction system collecting material with the following properties:

- MIE (Minimum Ignition Energy): See the product identification plate.
- MIT (Minimum Ignition Temperature): See the product identification plate.
- Kst: See the product identification plate.
- Pmax: See the product identification plate.

Materials with properties not within the values stated above or if a suppression or flameless system is used are to be investigated prior to use with FlexPAK DX. Contact Nederman for technical support and dust application investigation.

3.3 Explosion protection

The CE and ATEX markings on this unit ensure both a high level of safety and protection against ignition of the collected combustible dust. However, if an explosion occurs due to misuse, insufficient maintenance or faulty installation, this unit is equipped with additional protection methods to avoid dangerous pressure build-up in the filter.

FlexPAK DX is equipped with one of the following protection systems.

- Explosion venting, see [Figure 2A](#).
- Explosion suppression system, see [Figure 2B](#).
- Flameless venting, see [Figure 2C](#).

3.3.1 Explosion venting



The risk area may extend beyond the values given below. The final risk area is to be evaluated with regards to affecting factors found in Standard EN 14491.



For assistance and information, contact Nederman.

The harmful effects of an explosion are minimized by venting the pressure and flame of the explosion through an explosion relief panel, see [Figure 2A](#). In case of an explosion, the resulting flame and pressure escape through the explosion relief panel which is to be directed towards a safe area without any people. This area is referred to as the 'risk area'.

The risk area is to be clearly marked, for example with a fence, warning lines and signs, and entry is prohibited when the filter is in operation. Anyone operating in the vicinity of the risk area must be informed of the risks. The area is to be free of any flammable or combustible material or other objects which may be damaged by the flames and explosion pressure. It is advisable to use a deflector to direct the risk area away from areas where persons may be present. The unit shall be placed so that all operations may be performed without entering the risk area.

The general size of the risk area with or without deflector (accessory) is shown in [Figure 3A](#) and [Figure 3B](#). As a general rule the following dimensions apply:

- A 10 m (32,8 ft)
- B 4 m (13,1 ft)
- C 2,5 m (8,2 ft)
- D 5 m (16,4 ft)
- E 5 m (16,4 ft)
- F 5 m (16,4 ft)
- G 1 m (3.3 ft)
- H 0,5 m (1.7 ft)
- I 0,7 m (2.3 ft)
- J 5 m (16,4 ft)

In some cases, it is necessary to use a duct on the explosion relief panel to vent the flame and pressure to a proper safe area. Such a duct is to be able to withstand an overpressure of at least 0,5 bar (5,8 psi).



A vented duct affects the efficiency of venting so the efficiency needs to be calculated. Contact Nederman for assistance.

3.3.2 Explosion suppression system

With an explosion suppression system, the early stage of an explosion is detected with optical and/or pressure-sensitive devices, and an extinguishing agent is quickly dispersed into the filter, see [Figure 2B](#). The suppression of the explosion is initiated an extremely

short time after detection of the explosion (in milliseconds) and stops the pressure from rising and extinguishes (suppresses) the flames of the explosion.

This ensures that the filter is not stressed to a dangerous level by the explosion.

The key components of the explosion suppression system are the following:

- An explosion detection device (optical/pressure-sensitive).
- A computer-operated control unit.
- Action elements such as pressure cylinders containing an extinguishing agent with an extra fast opening valve.

Detailed information regarding system installation, function, operation and maintenance can be found in the suppression system manual.

3.3.3 Flameless venting

The method of flameless venting is similar to method 1 “explosion venting”. However, a device attached to the outside of the vent will stop flames from exiting the filter vessel. Such a device is sometimes referred to as a “quench-device” or “flameless-device”. See [Figure 2C](#).

Common for all types of flameless devices is that the explosion is released through a specially designed grid or mesh. The grid or mesh will allow pressure from an explosion to be released but prevent the explosion’s flames from exiting outside the filter vessel.

The benefit of using a flameless vent device is that it reduces the size of the risk area. This increases the possibility of positioning the FlexPAK DX closer to manned areas or equipment.

However, it must be noted that the use of a flameless device does not eliminate the risk area. The high pressure and hot gases are still released into the surroundings, and this must be taken into consideration when positioning the FlexPAK DX. Please consult your

local fire authority when determining suitable positioning of the FlexPAK DX with the flameless device.

Please refer to the installation and service or user manual for the flameless device supplied with the FlexPAK DX to find other limitations and information regarding safe use and service.

3.3.4 Isolation device

An isolation device, see [Figure 9](#), item 2, is to be installed to prevent a filter explosion from propagating back into the plant through the connected duct. The duct, see [Figure 9](#) item 3, between the unit and the isolation device, is to be pressure-resistant to an overpressure of at least 0,5 bar (7,2 psi) and have a minimum length as specified in the manual of the isolation device. The volume for FlexPAK is 0,47m³ in the isolation device. See also [Section 3.5 Technical data](#).

Duct isolation valve

 The reverse air cleaning pulse of the FlexPAK DX may cause the isolation device to close, which would result in the unit not functioning.

Due to the cleaning pulse, in most cases, it is necessary to install a damper upstream from the isolation device. Install the damper either one meter or five duct diameters from the isolation device in the duct from workstations. See [Figure 9](#) item 1 and [Section 3.8 Connections](#).

This damper is called a duct isolation valve and it must be closed during cleaning. It must also open slowly so that the vacuum in the ducting system does not cause a backflow through the isolation device. See the PLC Settings Manual.

3.4 Dimensions

 [Figure 2C](#) shows the dimensions of the inlet and one side of FlexPAK DX.

For the dimensions of FlexPAK DX, see [Figure 2A](#), [Figure 2B](#), and [Figure 2C](#).

3.5 Technical data

Table 3.1 Technical data

FlexPAK DX		
Power	18,5 kW (25 hp)	21,5 kW (29 hp)
Mains voltage/frequency	400 V \pm 10%/50-60 Hz	460 V \pm 10%/50-60 Hz
Maximum flow	1300 m ³ /h (765 cfm)	1300 m ³ /h (765 cfm)
Flow at -15 kPa	1000 m ³ /h (588 cfm)	1000 m ³ /h (588 cfm)
Flow at -20 kPa	800 m ³ /h (470 cfm)	800 m ³ /h (470 cfm)
Maximum vacuum	-35 kPa (-5,1 psi)	-35 kPa (-5,1 psi)
Filter area	6 m ² (64,5 sqft)	6 m ² (64,5 sqft)
Weight	454 kg (1000 lb)	454 kg (1000 lb)
Inlet/outlet diameter (flanged)	150/160 mm (7,87/6,29")	150/160 mm (7,87/6,29")
Sound level	70 dB(A)	70 dB(A)
Ambient temperature range	0 - +40 °C (32-104 °F)	0 - +40 °C (32-104 °F)
Process air temperature	0 - +60 °C (32-140 °F)	0 - +60 °C (32-140 °F)
Relative humidity	Max. 85%	Max. 85%
Compressed air	6-7 bar (87-102 psi)	6-7 bar (87-102 psi)
Material recycling	93,6% per weight	93,6% per weight
Control filter area	1x12 m ² (1x129 sqft)	1x12 m ² (1x129 sqft)
Control filter material	Polyester	Polyester
Maximum installation altitude	1000 m above sea level	1000 m above sea level
Corrosion class according to ISO 12944-2	C2 according to ISO 12944-2	C2 according to ISO 12944-2
Supply voltage to external equipment	24 VDC \pm 15%	24 VDC \pm 15%
Protection class	IP42	IP42

3.6 Fuses

Table 3.2 Fuses

Fuse	Size	Type
Main fuse F1, 400 V	35 A	Slow mains fuses
Main fuse F1, 460 V	40 A	Slow mains fuses
Transformer, primary fuse F2 and F3	0,8 A *	Slow fuses, 10,3×38
Transformer, secondary protection		PTC resistor
F4	50 mA *	Fast, 5×20
F5	1 A *	Slow, 5×20

* General size, see also included electrical diagrams.

3.7 Main components



WARNING! Explosion risk

- Never use the unit without an antistatic plastic bag.
- Depending on the FlexPAK DX model used, treat its explosion protection device carefully so that it does not become damaged, see [Figure 2A](#)



CAUTION! Risk of equipment damage

Use Nederman original bags only.

[Figure 4A](#), [Figure 4B](#) and [Figure 4C](#) show the main components of the unit:

- 1 Collector bin, see [Figure 4A](#).
- 2 Dust extractor, see [Figure 4A](#).
- 3 Textile filter bags, see [Figure 4A](#).
- 4 Filter holder, see [Figure 4A](#).
- 5 Filter Cleaning Valve (FCV), see [Figure 4A](#).
- 6 Connection duct from the dust extractor to the inlet silencer, see [Figure 4A](#).
- 7 Start and control unit, see [Figure 4A](#) and [Figure 4B](#).
- 8 Control panel, see [Figure 4A](#) and [Figure 4B](#).
- 9 Emergency switch, see [Figure 4A](#) and [Figure 4B](#).
- 10 Frequency converter, see [Figure 4A](#) and [Figure 4B](#).
- 11 Frequency converter cooling air filter, see [Figure 4A](#) and [Figure 4B](#).
- 12 Cooling valve, see [Figure 4A](#) and [Figure 4B](#).
- 13 High-pressure side channel fan, with pump characteristic, see [Figure 4A](#) and [Figure 4B](#).
- 14 PT100 sensor, see [Figure 4B](#).
- 15 Outlet silencer after fan, see [Figure 4B](#).
- 16 Control Filter and filter cartridge, see [Figure 4B](#).

- 17 Pressure sensor, see [Figure 4B](#).
- 18 Acoustic enclosure, see [Figure 4B](#).
- 19 Cooling air hose from the frequency converter cabinet, see [Figure 4C](#).
- 20 Compressed air supply, see [Figure 4C](#).
- 21 Inlet, see [Figure 4C](#).

3.8 Connections



The exhaust air duct is to be routed straight and as short a distance as possible.



The unit is CE-marked. Connections to the unit, initial start-up and maintenance are to be carried out according to the product manuals.

Equipment such as cables and hoses are not supplied and are to be obtained locally.

[Figure 9](#) shows the normal connections to the unit. They are as follows:

- 1 The duct from workstations.
- 2 Isolation device.
- 3 Pressure resistant duct between the unit and the isolation device.
- 4 Exhaust air duct, Ø 160 mm (for lengths <12 m).
- 5 PS cable from valves at workstations.
- 6 Incoming 3-phase power supply with a Protective Earth (PE) cable.
- 7 Compressed air supply, Ø 6 mm nylon hose.
- 8 Compressed air valve, size G1/4" or G1/2".
- 9 Water and dirt-trap. The compressed air supply is to be clean and dry.
- 10 Maintenance switch according to standard.
- 11 Power cable to the unit.

3.9 Start and control unit

3.9.1 Start and control unit

The unit has a start and control unit, see [Figure 5](#). The start and control unit has the following components:

- 1 Transformer TR1, 60 W.
- 2 Connection block for the transformer TR1.
- 3 Terminals for external emergency stop.
- 4 Vacuum setpoint switch.
- 5 Safety relay.
- 6 Transformer primary fuses F2 and F3, 6 A slow.
- 7 Programmable Logic Controller (PLC).
- 8 Data Unit 2 (DU2), I/O module.
- 9 AM 2 PT100, temperature sensor input expansion module.
- 10 Filter cleaning/test start button.
- 11 Standby/Running button, which is the On/Off button.
- 12 Emergency switch.
- 13 Terminals: X1: 1-80.
- 14 Fuse for 24 V DC accessory supply. Fuse F5, 1 A slow.
- 15 Terminals Protective Earth (PE).

3.10 Frequency converter



WARNING! Risk of electric shock

The frequency converter is not to be opened until 5 minutes after the supply voltage has been disconnected. The capacitors inside the converter hold a very dangerous voltage until they have discharged themselves.



CAUTION! Risk of equipment damage

- No parameters in the frequency converter may be adjusted without very detailed knowledge about the consequences. Adjustment voids the warranty.
- The unit is not to be started if the cooling hose has been removed.



[Figure 4C](#) shows the cooling air hose that improves the cooling of the frequency converter.



For parameter settings in the frequency converter, see the 'FlexPAK Frequency Converter Parameter Table' that is a separate document included with the unit.

The frequency converter controls the unit's motor so that it operates efficiently and maintains the unit's vacuum level to help prevent a dangerous negative pressure from developing and the unit overheating. The manual for the frequency converter is enclosed.

4 Accessories

The FlexPAK DX start and control unit is prepared for the connection of Nederman accessories and customer connections.

The installation of accessories, extra equipment, and functions is described in the manual for each product and according to the electrical diagrams that came with the unit. Consult your local Nederman representative for available accessories.

The most common accessory is a PS cable, which allows remote start/stop signalling from the valves on the duct system. See the PLC Settings Manual for more information about messages and settings for accessories, and customer connections.

5 Installation



WARNING! Explosion risk

- Some types of dust may cause a dust explosion and/or fire. Before installation, investigate whether the dust to be collected by the system constitutes a risk.
- We recommend that fire alarms and appropriate extinguishing systems are to be installed at all locations where collected combustible dust is stored.



WARNING! Risk of personal injury

- Use proper lifting and protective equipment.
- Be careful not to let the unit tip over to avoid a crushing risk.
- The unit is to be anchored to the floor, particularly if it is located at a high level, to ensure that it does not move and fall down. The frame has four holes for anchoring. Take care during relocation and transport of the unit to avoid tipping. If the unit is to be moved, the frame is to be attached to the front of the bottom frame, see [Figure 10](#), item 1.



Standards relating to the connection and use of filters in hazardous areas are to be taken into consideration, especially national standards for installation. Only trained personnel familiar with these standards is allowed to handle this type of filter.



The designer of the system as a whole has to guarantee the correct function of all interacting products or components and ensure that the complete system meets all necessary safety requirements.



Make a layout for the entire system before installing the unit.



Fill in the installation protocol during installation, see [Chapter 9 Appendix A: Installation protocol](#).

5.1 Delivery check

Check the unit for any transport damage. In case of damage or missing parts, notify the carrier and your local Nederman representative immediately.

5.2 Installation requirements

Prepare the location where FlexPAK DX is to be placed before installation. Consider the following when installing the unit:

- The unit is to be anchored to a hard, level and firm foundation. There are four fastening brackets on the bottom frame to be used to fasten the unit to the raised foundation.
- The total weight of the unit with accessories.
- Traction forces generated by explosion relief venting, see [Section 5.2.1 Bolts](#).
- Maximum weight of the collected material.
- Do not install the unit close to heat sources or hot surfaces.
- Beware of hot air from the outlet.
- Ensure that handling is convenient.
- Ensure that emptying collected dust is convenient.
- Ensure that service and maintenance are convenient.
- In case of high relative humidity, do not expose the unit to freezing temperatures.
- Do not place the unit in direct sunlight.
- Ensure that reverse airflow into the outlet is prevented.

5.2.1 Bolts

Each of the anchor bolts securing the unit is to withstand traction forces of 6,5 kN vertically and 2,5 kN horizontally. See also [Figure 10](#).

Recommended bolts for concrete are Hilti HDA-PF 20-M10×100/20. If expansion bolts are to be used, the concrete foundation is to be prepared according to bolt recommendations.

5.3 Duct dimensions and installation

[Figure 9](#) shows the unit installed in a typical vacuum duct system.

5.3.1 Requirements

Place a sign with the intended use of the vacuum system on every user interface (workstation). Inform all personnel of the intended use of the system. Ensure that personnel using the equipment do not collect items that may cause ignition or blocking.



WARNING! Explosion risk

- The ducting is to be built with a plain steel pipe. Plastic pipe, such as PVC, is not to be used. Almost all types of dust pick up static electricity when sucked through a plastic pipe, which significantly increases the risk for an explosion if the dust is combustible.
- Do not collect material that may cause ignition or blocking. It is strictly prohibited to collect material that may undergo dangerous chemical or thermal reactions and/or self-ignite.
- Some types of dust may cause a dust explosion and/or fire. Before installation, investigate whether the dust to be collected by the system constitutes a risk.
- The silencer outlet for exhaust air is to be directed upwards. Fit a Spiro duct to direct the exhaust into the atmosphere. The duct is to be routed to prevent any particles from falling into the unit, which could cause serious damage
- Self-ignition can occur with some types of dust. Under no circumstances may magnesium and titanium dust be sucked into the system.



All connected ducts are to be conductive and grounded.

5.3.2 Recommendations

Transport velocity

It is important to use the correct duct diameter to avoid pressure losses and dust deposits in the duct system. Ensure that the correct transport velocity is achieved. Correct velocity depends on the properties of the transported material. Some applications may require velocities up to 25 m/s (82 ft/s). Take velocity into account when choosing duct diameters. The velocity is never to decrease on the way to the unit. The transport velocity in the ducts may vary depending on how much of the vacuum system is used.

Flushing

Depending on the type of dust and fumes to be filtered by the unit, a principle called flushing may be used to keep the vacuum ducts clean. Flushing may be applied by fitting a valve at the end of the duct system. By not using the rest of the system, and opening the so-called flush valve, a high amount of air will flush the ducts clean. By flushing each branch of the vacuum system separately, the risk of dust deposits is minimized.

In larger vacuum systems with multiple units installed, the installation of Duct Isolation Valves (DIV) is recommended in order to isolate one unit for maintenance while the others remain in normal operation.

If the dust is abrasive, it may be necessary to use thick-walled (or rubber-coated) material in bends and other exposed areas.

To avoid pressure losses, the duct system is to be as short as possible and designed with two or more branches. Use larger diameters on the clean side to reduce pressure losses.

5.4 Installing the unit

⚠ WARNING! Risk of personal injury
Always stop the unit before looking into the outlet. The fan rotates at high speed and debris and particles coming out of the outlet may cause eye injury.

i For suppression units, detailed information regarding the installation of an explosion suppression system can be found in the suppression system manual. Work is only to be carried out by certified personnel.

i To minimize any secondary explosion damage and spread of fire, the proper documentation and checklists of how to handle a fire in the unit have to be developed. Such documents are to be developed in co-operation with the local fire authorities and take into account the properties of the collected material.

5.4.1 Indoor installation

⚠ CAUTION! Risk of equipment damage
If the exhaust air duct is blocked, the unit may create an overpressure, that may cause major damage to the heat exchanger.

i Never completely seal a small room with the unit installed.

i Ensure that the room where the unit is installed is well ventilated.

It is recommended that the unit is positioned indoors.

Under some conditions, the unit may draw air directly into the high-pressure fan. This may cause a dangerous underpressure in the room if air cannot enter freely. There are to be two openings for ventilation, at least 250×250 mm (10"×10") in size. One is to be placed up high and the other one down low.

The warm exhaust air is to be directed from the unit and out of the premises, see [Figure 9](#), item 4. Connect a duct that directs the exhaust air outdoors.

The air can be directed to a heat exchanger, but there are not to be any dampers that may obstruct the air flow.

5.4.2 Outdoor installation

If installed outdoors, consider the following:

- The area needs to be protected from the weather. Cover the top of the unit to protect it from snow, rain or falling debris.
- Install a lightning conductor, see [Section 5.7 General requirements](#).
- Environmental and ambient conditions. See [Section 3.5 Technical data](#).

5.4.3 Moving the unit

⚠ WARNING! Risk of personal injury

- Use proper lifting and protective equipment.
- Be careful not to let the unit tip over to avoid a crushing risk.
- The unit is to be anchored to the floor, particularly if it is located at a high level, to ensure that it does not move and fall down. The frame has four holes for anchoring. Take care during relocation and transport of the unit to avoid tipping. If the unit is to be moved, the frame is to be attached to the front of the bottom frame, see [Figure 10](#), item 1. Before moving the unit ensure that it is emptied of extracted materials.

5.5 Electrical installation

⚠ WARNING! Risk of electric shock

- Work with electric equipment is to be carried out by a qualified electrician.
- The connected wiring system is to be electrically connected to the Potential Equalizing System (PES) on the premises.

i The electrical connection is NOT to be equipped with an earth leakage circuit breaker when the frequency converter is provided with an EMC filter. The EMC filter function will make the earth leakage circuit breaker shut off the power.

i Following the European standard, the incoming 3-phase supply is to be fitted with a hand-operated disconnecting device that conforms to the demands of disconnectors. The disconnecting device is to be fitted within 2-3 m from FlexPAK DX and be clearly visible from the unit. Refer to local and national standards when located outside of Europe.

i Check the continuity of the protective current circuit before the unit is used.

i Check that the supply voltage corresponds to the data on the machine plate of the unit, see [Figure 1](#), before connecting the unit to the mains supply.

i Control that TR1, see [Figure 5](#), item 2, is connected to the correct voltage range and verify its output voltage before using the unit.

i Always replace worn, faulty or defective electrical components with new original parts.

For the power circuit, control circuit and terminal connection diagrams, see the electrical diagrams that came with the unit. The unit is not to be connected to the supply voltage via plug and socket but shall be permanently connected. Ensure that all electrical connections are secured properly.

5.6 Suppression system installation

i Information regarding installation of the active elements and control system can be found in the suppression system manual. Work is only to be carried out by personnel that are certified for installing suppression systems.

An explosion detection signal from the suppression system must be connected to FlexPAK DX terminal 42-43, see the included electrical diagrams.

Other suppression system signals must be taken into consideration and connected to suitable warnings and/or notification systems for the users.

5.7 General requirements

The following items are minimum requirements to ensure the proper function and required level of protection with regards to equipment category, the EC directives and standards listed in the Declaration of Conformity:

- Take proper measures to avoid all types of electrical stray currents to and from the duct system and electrical wiring.
- Check that the input voltage and frequency to the unit are correct.
- Operator controls shall be easily accessible.
- The need for additional emergency stop buttons and their placement shall be analyzed according to EN ISO 13850.
- A lightning conductor is to be installed if the unit is installed outdoors. The installation of the lightning conductor is to follow national and local regulations for such a protection device.

5.8 Automatic bin emptying function

See the PLC Settings Manual.

5.9 Machining chips and swarf extraction

See the PLC Settings Manual.

5.10 Pneumatic filter cleaning valve

See the PLC Settings Manual.

5.11 ATEX Duct Isolation Valve

See the PLC settings Manual.

5.12 Ground check measurement

i All metal parts of the unit are to be grounded. The system is to have two independent ground connections; one on the FlexPAK DX (GND1) and the other one on the duct system. Follow the procedure below to ensure this.

i The duct system (inlet and outlet) is NOT to be connected during the measuring.

Check that the unit is properly grounded after both the main installation and regular maintenance work. If a component is removed and refitted, the ground connection is to be verified.

See the electrical diagrams. The ground connection is measured between GND1, terminal PE, and the following components on the unit:

- 1 Spring in filter bags, see [Figure 4A](#), item 3. Measure when unassembled.
- 2 Explosion suppression device, see figures, [Figure 7](#) and [Figure 2A](#), [Figure 2B](#) and [Figure 2C](#):
 - The pipe of the explosion suppression device, [Figure 7](#) item A.
 - A screw on the explosion venting panel, [Figure 7](#) item B.
 - A screw on the quenching device.
- 3 Inlet, see [Figure 4C](#), item 21.
- 4 Collector bin, see [Figure 4A](#), item 1.
- 5 Fan, see [Figure 4A](#) and [Figure 4B](#), item 13.

To measure the ground connection:

- 1 Disconnect mains ground from GND1.
- 2 Measure between all components according to the list above and GND1. The value is to be ≤ 100 ohms.
- 3 Measure and check whether there is contact between the incoming duct system and the disconnected incoming mains ground. The value is to be ≤ 105 ohms except for the spring in filter bags, [Figure 4A](#), item 3, where the limit is 1 mega-ohm.
- 4 Connect the incoming duct system. Ensure that there is a second ground connection between the duct system and the unit and that it is properly grounded to the unit.
 - 1 Measure and check whether there is contact between GND1 and the external mains ground (≤ 100 ohms).
- 5 Reconnect mains ground to GND1.

- 6 Connect the outgoing duct system. Ensure that there is a ground connection between the duct system and the unit.

5.13 Vacuum setpoint

Performance settings with two typical running modes:

1000 m³/h at -15 kPa, max vacuum 20kPa or 800 m³/h at -20 kPa, max vacuum 35 kPa. The vacuum setpoint can be switched between -20kPa and -35kPa by altering a terminal X2:1 in the control box. The default setting is -20kPa.

See [Figure 5](#) item 4 and the wiring diagram.

5.14 Rotary valve

See the PLC Settings Manual.

5.15 Compressed air installation



WARNING! Risk of personal injury

- Use ear protection and safety goggles.
- The compressed air valve is to be locked in the closed position during maintenance.

5.15.1 Requirements



The specified air consumption of the unit is limited to the short operation of the cleaning valve.



Take measures necessary to avoid water or humidity in the compressed air when the unit is installed in cold environments.



If antifreeze additives are used, use them continuously. Once added, the removal of the antifreeze additive may cause the pneumatic components to malfunction.

For air consumption, quality and maximum and minimum pressure, see [Section 3.5 Technical data](#).

As new ducts may contain dirt, particles or debris, the compressed air pipe is to be blown clean before connecting the unit. A compressed air filter, see [Figure 9](#), item 7, is to be installed to ensure the reliable and safe operation of the unit. A compressed air valve, that vents the remaining pressure of the unit, is to be installed, see [Figure 9](#), item 6.

5.15.2 Installation



Secure the compressed air line properly.

Connect a compressed air supply to the inlet, see [Figure 5](#), item 20, and [Figure 9](#), items 6 and 7.

Air pressure hoses are to be fitted together with electrical cables with straps, alternatively in a common protective hose. Air pressure hoses are to be anchored mechanically.

6 Maintenance

Read [Chapter 3 Description](#) before carrying out any maintenance work. Maintenance work means that the equipment will have to be opened and possibly dismantled. This may constitute a risk and the maintenance personnel need to know about the risks that may occur when acting incorrectly.



WARNING! Explosion risk

Stop operation and clean the entire filter thoroughly from dust before any grinding, welding or other hot works are performed on the filter exterior or inlet.



WARNING! Risk of personal injury

- The motor, fan and air duct may become very hot during operation.
- Always use an approved breathing mask, goggles and gloves when replacing the dust sack and other work that involves exposure to dust.
- Use ear protection when the unit is in operation and work is carried out in the vicinity of the upper section of the dust collector.
- Parts may be very heavy. Always use adequate lifting equipment when handling parts and consumables.
- Always use adequate safety measures when performing work in an elevated position.



CAUTION! Risk of equipment damage

During maintenance, it may be necessary to remove the acoustic enclosure over the motor while the motor is in operation. Take care to prevent objects from falling down into the motor cooling fan.



Always disconnect the supply voltage with the maintenance switch before any service, whether mechanical or electrical. Always lock the maintenance switch in the off position and, if possible, secure it with a padlock.



Always disconnect the compressed air supply before any service, whether mechanical or electrical.



Contact Nederman if the frequency converter needs service.



The unit is CE-marked. Connections to the unit, initial start-up and maintenance are to be carried out according to the product manuals.

6.1 Service and maintenance of ATEX equipment

To ensure the required level of protection, ensure that the following is performed:

- FlexPAK DX is regularly inspected for damage or malfunction. If FlexPAK DX is damaged, it is to be shut down and any explosive atmosphere removed.
- There is to be no explosive atmosphere when servicing or inspecting FlexPAK DX.
- Only Nederman original spare parts are to be used.
- FlexPAK DX is not to be covered with thick dust layers (>5 mm). This is prevented by setting up routines for regular cleaning and including these in the explosion protection document.

6.2 Checks one month after installation and every year



WARNING! Risk of electric shock

Always disconnect the supply voltage with the maintenance switch before any service, whether mechanical or electrical. Always lock the maintenance switch in the off position. Do not use the emergency stop button as a substitute.



WARNING! Risk of personal injury

- Ensure that there is no vacuum present in the system during service.
- Always disconnect the compressed air supply before any service.



Check all power conductors and protective conductors one month after installation and tighten, if required, to ensure good contact. Service to the electrical equipment may only be carried out by a qualified electrician.

One month after installation, and then every year, perform the following checks:

- Check all power and protective conductors and ground wire connections. Tighten, if required, to ensure good contact.
- Inspect the integrity of the dust separator.
- Ensure that the inside of the unit and the connection ducts are free from deposits. A build-up of deposits inside the duct system may cause the discharge of static electricity.
- Clean the area around the unit and all areas where the collected material is stored to ensure that there are no dust deposits.
- Ensure that there is not any combustible material in the risk area.
- Check that all signs/markings regarding safe operation are in place and that the personnel knows about them.
- Verify the function of all emergency stop buttons, alarms and signalling devices.
- Inspect the explosion venting panel and verify that it is intact.

6.3 Empty the collector bin



WARNING! Risk of personal injury

- Ensure that there is no vacuum in the dust separator before removing the collector bin.
- Crush hazard. Be careful when lowering and refitting the collector bin. Use proper protective equipment.
- Wear goggles, a dust mask and gloves when emptying the collector bin.



The plastic bag is to be replaced when filled up to 2/3, see [Figure 11](#).

Do the following to replace the plastic bag:

- 1 Check that the risk area is clear.
- 2 Ensure that there is no vacuum in the dust separator.
- 3 Remove the collector bin.
- 4 Seal and remove the plastic bag. Use a cable tie or equivalent, see [Figure 12](#).
- 5 Fit a new antistatic plastic bag in the collector bin, see [Figure 13](#).
- 6 Refit the collector bin onto the dust separator.
- 7 Check that the pressure equalizer hose is attached to the collector bin, see [Figure 14](#).
- 8 Check that the collector bin seals properly once the vacuum is re-applied to the dust separator.

6.4 Replace the main filter



WARNING! Risk of personal injury

If a flameless venting device is used, FlexPAK DX is heavy so lower the unit carefully. It can fall on the individual replacing the filter or get damaged.



Fitting the steel ring correctly is important to maintain the tightness and durability of the unit. Do not forget to ground it. See [Figure 17](#).

Filter replacement is to be noted in the service protocol of the unit. Replacing individual filter bags is possible, but it is recommended that the whole filter package is replaced since it is quicker and causes less spreading of dust. The work is easy if the unit is placed so it can be tilted, see [Figure 15](#). Also, the filter may be lifted straight up, see [Figure 16](#), with a crane or other lifting device.

If the filter bags are replaced separately, the plastic holders will also have to be replaced.

[Figure 17](#), items A-C, shows how the rubber sealing rings are to be fitted. When a used sealing ring is to be re-used, the form when open may differ from the original form as shown in item A. Use a screwdriver to bring the edge of the module between the rubber lips to obtain the result shown in item C.

6.5 Change control filter



WARNING! Risk of personal injury

- The vacuum and compressed air to the unit must be turned off before commencing filter change.
- Use proper protective equipment.



Always check the main filter for damage when replacing the control filter.

The control filter should normally be replaced after 6000 hours of operation. The control filter must also be replaced if damaged or if there is a high-pressure drop over the control filter.

Follow the procedure below:

- 1 Access the filter by removing the lid and side of the FlexPAK DX.
- 2 Disconnect the top piping of the filter housing and open the top cover.
- 3 Remove and put the old filter in a large plastic bag, or wrap it in plastic foil. Avoid dust spreading.
- 4 Fit a new filter cartridge in place. Ensure that the filter cartridge is centred and that the rubber seal on the housing is intact.
- 5 Close the top cover and reconnect the pipes.
- 6 Check the earth connection between the control filter and GND1.

6.6 Check the filter cleaning function



WARNING! Risk of personal injury

Crush hazard. Pay attention when the compressed air pressure cylinder and valve disc move. Make sure that the protection hood over the filter cleaning unit is fitted after the check.

Check the automatic filter cleaning as follows:

- 1 Check the automatic cleaning equipment once a year.
- 2 Remove the top cover from the filter and inspect the valve disc.
- 3 Start the unit and press the filter cleaning button, see [Figure 8](#). The compressed air cylinder should lift the valve disc. Loud noise can be heard as air rushes into the filter bin to blow off the dust from the outside of the filter package. This will be repeated 3 times for each filter cleaning cycle.
- 4 Stop the vacuum unit and shut off the air supply.
- 5 Check the valve disc fastening, damage and wear. Replace if required.
- 6 Replace the protecting top cover.

6.7 The motor and the fan unit

Inspect and clean the motor compartment regularly.

The motor has 2 ball bearings. The bearings are to be replaced after approximately 15,000 hours of operation. If the ambient temperature often reaches 35°C (95°F), the time between replacements is to be reduced. In any case, the bearings are to be replaced every fifth year.

The bearings are a standard type. Contact Nederman or an authorized Nederman distributor for replacement of the bearings.

Old grease is to be removed and new grease used. The grease is to meet the DIN 51825-K2N 40, SKF LGHP 2 or FAG Arcanol Multitop standards.

6.8 Cooling filter for the frequency converter

The service life of the cooling filter for the frequency converter depends on the air-bound dust surrounding the vacuum unit. The expected service life is 6-48 months. Check the filter regularly through the filter holder grid. If the filter is clogged, the frequency converter will shut off due to overheating.

Ensure that the cooling filter is not exposed to any combustible materials. Running the unit without the cooling filter may cause serious damage. When changing the filter, see the label placed over the filter intake.

The unit may never be run without a cooling filter for the frequency converter.

6.9 Loading new software



This section is only for Nederman qualified service technicians. Only Nederman qualified service technicians may make changes to, or install new software.



Make notes of actual parameter settings.

6.9.1 Frequency converter control panel

To change the software or install new software for the unit, the parameters in the frequency converter have to be changed by means of the frequency converter control panel available from Nederman.

6.9.2 Firmware and software labelling



The software version is found on a label taped to the front of the PLC. LOGO 8 software is updated using an SD Card. Follow the included instructions when the software needs to be updated.



To find the firmware and software revision number in the PLC display, see [Figure 8](#), item 1. Pressing 'OK' when the PLC displays this menu will show this information. See also the PLC Settings Manual.

The firmware and software revision can be read in the PLC and also on the label on the PLC.

The number, 2155264-2-EN for example, consists of the following parts:

- 2155264 = The software number.
- 2 = The revision.
- EN = The language of the display text.

6.9.3 Upgrading the system

LOGO 8 software is updated using an SD Card. Carefully follow the included instructions when the software needs to be updated.

6.10 Spare Parts



CAUTION! Risk of equipment damage

Use only Nederman original spare parts and accessories.

Contact your nearest authorized distributor or Nederman for advice on technical service or if you require help with spare parts. See also www.nederman.com.

6.10.1 Ordering spare parts

When ordering spare parts always state the following:

- The part number and control number (see the product identification plate).
- Detail number and name of the spare part (see www.nederman.com/en/service/spare-part-search).
- Quantity of the parts required.

6.11 Recycling

The product has been designed for component materials to be recycled. Different material types must be handled according to relevant local regulations. Contact the distributor or Nederman if uncertainties arise when scrapping the product at the end of its service life.

6.11.1 Environmental information

The following environmental information is valid for FlexPAK DX:

- Cadmium-free and halogen-free relays in the control equipment.
- Solvent-free washing and lacquer.
- 93,6% recyclable.

7 Troubleshooting

For information on fuses, see [Section 3.6 Fuses](#) and the included electrical diagrams.

There is no overcurrent relay. The frequency converter parameter for maximum current is adjusted from the factory and is not to be adjusted.

If a fault occurs which cannot be adjusted according to the following descriptions, a Nederman service technician is to be called.

7.1 Tools

To carry out troubleshooting, it is necessary to have a multimeter with V DC and ohm measuring capabilities.

7.2 Remove the lid of the start and control unit

Remove the lid as follows:

- 1 Unscrew the four plastics screws in the corner of the control cabinet.
- 2 Lift of the lid.
- 3 Identify the PLC and the terminals at the bottom of the cabinet.

Table 7.1 Troubleshooting guide

Error	Possible cause	Solution										
The unit unexpectedly goes directly into Running mode when the Standby/Running button is pressed.	<ul style="list-style-type: none"> • A valve at a workstation is open and its micro switch is activated • The PS cable is damaged with its wires short-circuited 	<p>If the PS cable is damaged, press the Standby/Running button to put the unit into Off mode and investigate the fault. If necessary, loosen the PS cable from the control unit, see the electrical diagrams, and use an ohmmeter across the leads in turn to locate the fault.</p>										
Defect PT100 temperature sensor.		<p>Check whether the PT100 sensor is defective as follows:</p> <ol style="list-style-type: none"> 1 Disconnect the PT100 sensor wire from terminal 77 and measure the resistance between terminal 78 and the disconnected sensor wire. 2 Measure the resistance in the sensor using an ohmmeter. The values in the table below are standard values, so a deviation from the measured value is normal. If the averaged output (in ohm) deviates more than $\pm 2\%$ from these values, the sensor will need to be replaced. <table border="1" data-bbox="810 1480 1465 1796"> <thead> <tr> <th>Temperature (°C)</th> <th>Averaged output (ohm)</th> </tr> </thead> <tbody> <tr> <td>0</td> <td>100</td> </tr> <tr> <td>20</td> <td>110</td> </tr> <tr> <td>80</td> <td>131</td> </tr> <tr> <td>135</td> <td>150</td> </tr> </tbody> </table> <p>If the sensor has a resistance >150 ohms, there will be a high-temperature alarm. To check whether the sensor input is working correctly, disconnect the PT100 wire at terminal 77 and connect a jumper between terminals 77 and 78. Press the OK button on the PLC to reset the alert.</p> <p>If the alert disappears, the PT100 sensor input is working, and the PT100 sensor will need to be replaced.</p>	Temperature (°C)	Averaged output (ohm)	0	100	20	110	80	131	135	150
Temperature (°C)	Averaged output (ohm)											
0	100											
20	110											
80	131											
135	150											

Error	Possible cause	Solution
Defect pressure sensor.		<p>The pressure sensor is connected to PLC input 8 and an inverter input +AI1 terminal (2). The sensors measurement range is 0 to -40 kPa. The signal goes from 10 to 0 V and 0 to -40 kPa, which gives 10 V at 0 kPa and 0 V at -40 kPa.</p> <p>Measure the voltage signal at the inverter, between terminals 2 (+) and 7 (-). When the motor is off, the input signal at terminal 2 has to be 10 V, and when the motor is running, the signal is 0 to 10 V depending on the pressure level in the system.</p> <p>To check whether the sensor input is working, disconnect the pressure sensor wire at terminal 2 and connect a jumper between terminals 2 and 1. Press the OK button on the PLC to reset the alert.</p> <p>If the alert disappears, the pressure sensor input is working and you will have to replace the pressure sensor.</p>
Low vacuum or air flow.	Deposits or blockage in ducts on the way to the unit.	<ul style="list-style-type: none"> • Clean the ducts. • Check the transport velocity.
	The duct system is not properly dimensioned.	Re-dimension the duct system or add an extra suction source.
	Valves in the duct system are not working.	Check the duct system valves.
	The filter cleaning does not work or is insufficient.	Check the function of the filter cleaning.
Control filter pressure sensor is activated.	The control filter is blocked.	<ul style="list-style-type: none"> • Turn off the fan and check that the yellow fault indicator light goes out. If not, the pressure sensor is broken or the airlines blocked. • Replace the control filter. • Check the main filter for damage.
	The Ø 6 mm hoses to the pressure sensor are blocked or damaged.	Clean or replace the hoses.
	The pressure sensor and/or filter are not connected properly.	Check the connections.
	The pressure sensor is set too low.	Increase the setting (default: 4 kPa (0,58 psi)).
	The pressure sensor is broken.	Replace

Error	Possible cause	Solution
Filter cleaning does not work.	<ul style="list-style-type: none"> • Problem with (PS) cable • DIR_time settings 	If the unit does not go into Idling mode and filter cleaning does not take place after 10 seconds, break the PS cable manually by opening fuse holder F4. Wait at least 10 seconds. If switching to Idling mode occurs this time, troubleshoot the PS cable. If switching does not occur, check the time set on the display (DIR_time function).
	The compressed air pressure or flow is too low.	<ul style="list-style-type: none"> • Adjust the pressure. • Check the hose dimension
	The solenoid valve is not connected properly.	Check the valve and air pressure.
	The air lines, valve and/or cylinder are blocked.	<ul style="list-style-type: none"> • Clean or replace the air lines, valve and/or cylinder. • Filter incoming compressed air.
	The cylinder and/or valve does not work.	Replace the cylinder and/or valve.
	Dust is hard to clean, normal cleaning does not work.	Contact your nearest authorized distributor or Nederman for technical advice.
	The cleaning interval is too short.	Extend the cleaning interval.
Compressed air, (Pr/t) is <1 bar.		<p>See Section 3.5 Technical data. Too low compressed air pressure can result in premature filter clogging. If the pressure is lacking or too low, the piston cannot open the FCV and lid properly. This results in insufficient cleaning and premature filter clogging.</p> <p>The CAS is connected to terminals X1:15 and X1:16. If no CAS is installed, a jumper is linking the terminals to ensure that the CAS message is not displayed in PLC Logo!</p>
No dust is collected in the collector bin.	Filter cleaning does not work.	See Chapter 6 Maintenance .
	Insignificant flow to the unit.	See 'Low vacuum or air flow'.

8 Acronyms and abbreviations

AEB	Automatic emptying of the bin
AUX	Auxiliary
BLI	Bin level indicator
BLI-Wr	Bin Level Warning indicator
CAS	Compressed air switch
CFDPS-AI	Control Filter Differential Pressure Sensor Alarm
DIR	Duty/idle relay
DIV	Duct isolation valve

DU	Data Unit
EMC	Electromagnetic compatibility
EPROM	Electrically erasable programmable read-only memory
FC	Filter cleaning
FCR	Filter cleaning relay
FCV	Filter cleaning valve
MFDP	Main Filter Differential Pressure Sensor
MFDP-FC	Main Filter Differential Pressure Sensor Filter Cleaning
MFDP-Wr	Main Filter Differential Pressure Sensor-Warning
MI	Maintenance interval
OT	Operating total
PE	Protective earth
PLC	Programmable logic controller
PS	Pilot signal
PSIFC	Pilot signal interlock filter cleaning
PTC	Positive temperature coefficient
PES	Potential equalization system
PVC	Polyvinyl chloride
RPS	Relief Panel Sensor
SLV	Solenoid lower valve
SSR	Start/stop relay
SUV	Solenoid upper valve
TVFD	Twin valve feed-out device

9 Appendix A: Installation protocol

Copy the installation protocol, fill it in and save it as a service record.

For values, note the value in the result column, otherwise, a tick will suffice if the item has been performed or considered.



If a value is outside the limit or a result is incorrect or missing, this is to be rectified before the initial start-up and normal operation.

Correct limits or results are given within brackets.

Unit No.	Date:	
	Performed by:	

Control items	Result
Application requirements (limits)	
Material chemical/thermal reaction risk	
Radiation heat from surroundings	
Delivery checks	
Missing components	
Transport damage	
Before installation	
Foundation	
Total weight (product, accessories, and collected material)	
Anchor bolts	
Access for maintenance/filter replacement (1 m above the unit)	
Mounting (check availability)	
Maintenance switch	
Installation room, ventilation openings	
Plastic bag	
Duct system	
PS cable (optional)	
Start and control unit, terminals 3-4	
Duct system	
Duct dimensioning/transport velocity, check the performance	
Pressure resistant duct	

Control items	Result
Application requirements (limits)	
Electrical installation	
Connections - Start and control unit	
Connection - power cable, check tightness	
Compressed air	
Air lines cleaned	
Air pressure	
Clean and dry air	
Compressed air valve	
Compressed air connected to the unit	
Ground check measurement Check:	
Incoming duct - Incoming mains ground	
GND1 - External mains ground	
Accessories (if applicable)	
Signs and warnings	
Intended use marked or indicated	
Safe bag replacement described or indicated	
Initial start-up (function test)	
Maintenance switch	
Motor, the direction of rotation	
Automatic filter cleaning	
Manual filter cleaning	
Cover on the start and control unit fitted	

10 Appendix B: Service protocol

Copy the service protocol, fill it in and save it as a service record.



If the results of the checks (for example, measured values) differ significantly from previous results, investigate more carefully.

Unit No.	Date:	
	Operating hours:	
	Performed by:	

Control items	Result	Result	Result	Result
Manual Nut VV				
Previous service record				
Inspect/clean outside the unit				
Remove dust deposits, clean work area				
Remove corrosion by grinding, apply primer and touch up paint				
Vacuum, measure negative pressure				
Cooling valve				
Motor bearings				
Fan				
Cooling fan, motor				
Bearing motor/fan				
Safety switch				
Box/housing				
Main switch				
Cable harness				
Electrical connection points				
Ground (earth) connection				
Indicator lamps				
Inverter				
Cooling air filter, functional control, frequency inverter				
Cooling air filter, exchange				

Control items	Result	Result	Result	Result
Rated current				
Seals				
The clean side of the filter				
Connecting hose vacuum				
Cylinder				
Valve plate				
Automatic filter cleaning, check				
Manual filter cleaning, check				
Power conductor connections and ground wires, check				
Vacuum limiting, check				
Cleaning valve, check				
Filter bags, visual check				
Filter bags, check pressure drop/performance				
The main filter, replace				
Clean and dry air, check				
Ground measurement, check:				
GND1 - Fan				
Incoming duct - Incoming mains ground				
GND1 - External mains ground				
Gaskets, check for leakage and replace, if necessary				
Plastic bag, replace				
Bearings, motor, replace				
Bearings, fan, replace				
Check that the ventilation of the room is clear (if placed indoors)				
Start and control unit cover, check				
Signs and warnings, present and legible				

Nederman

www.nederman.com