

SiloSafe Filter

SiloSafe Feature

SiloSafe 24 and SiloSafe 24F are compact, reverse jet cartridge filters designed particularly for ventilation pneumatically filled storage silos.

Nederman serves virtually all industries including:

- *Cement*
- *Minerals & quarry*
- *Agriculture*
- *Food & Feed*
- *Woodworking*
- *Metal*
- *Foundry & Aluminium*
- *Chemical*
- *Plastics*
- *Rubber*
- *Asphalt*
- *Pharmaceuticals*
- *Paint*
- *Paper & Printing*
- *and other...*



Silo Venting: 1,500-2,300 m³/h

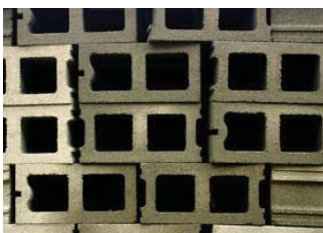

SiloSafe Dimensions

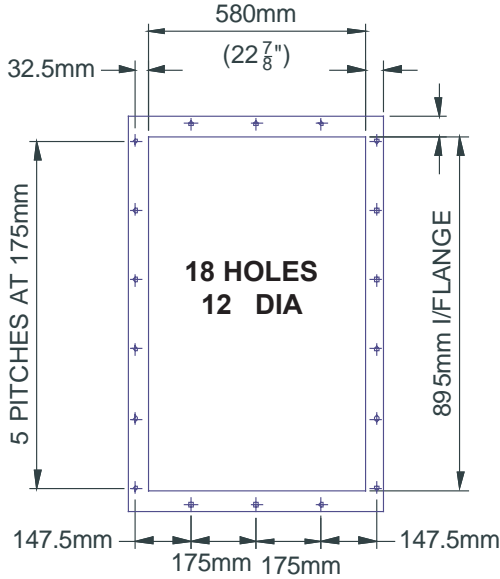

FILTER MAINTAINING FLANGE DETAILS

SiloSafe 24

3/4" BSP female connection for air supply.

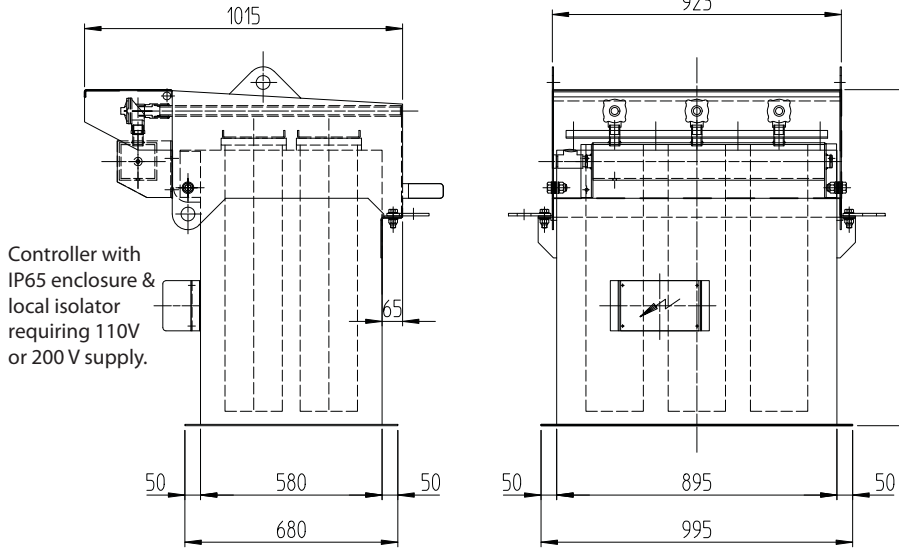

SiloSafe 24 F

3/4" BSP female connection for air supply.

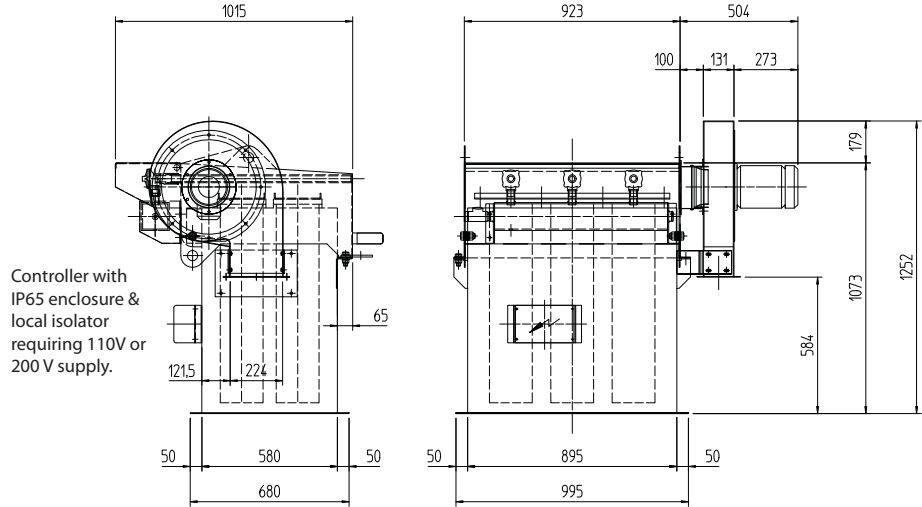

Feature



The SiloSafe 24 design is based upon years of experience manufacturing, selling and servicing silo venting filters, extensive discussions with silo manufacturers, purchasers and batching plant operators.

Advantages:

- Low profile for neat, unobtrusive appearance
- Galvanised finish for long, corrosion free service
- Heavy gauge fully-welded steel construction
- Generous 24m² filter area to handle virtually all materials delivered pneumatically to silos
- Easy access to top-removal cartridges for safe maintenance
- Patented UniClean cartridges offer enhanced cleaning, higher efficiency and longer life

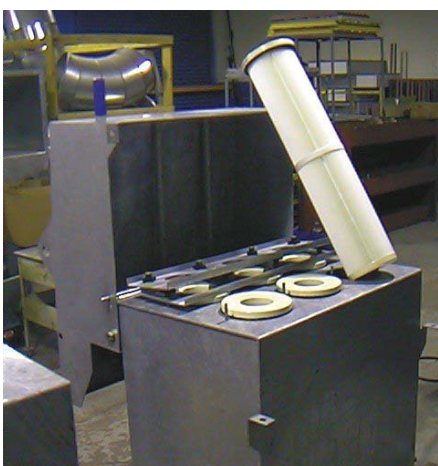

Options:

- Fan (SiloSafe 24F): high efficiency backward curved radial fan with up to 2.2 kW, 3 phase induction motor.
- Four cartridge materials.

Technical parameters:

- Filter body in 4mm-thick steel, fully welded and hot-dip galvanised,
- Internal explosion pressure rated at 0.75 bar (test pressure 1.35 bar)
- Airflow volume typically up to 2000 m³/h
- Six cartridges; filter area 24m²
- Cartridges replaced from clean air side
- Normal cartridge cleaning pressure: 5.5 bar compressed air supply
- Compressed air consumption - typically 60 normal litres per pulse
- Reverse jet controller in IP65 box; power supply 220 V – 50 Hz
- Three 1" diaphragm valves with directly coupled solenoid valves, 110v AC
- Unit weight:
SiloSafe 24 - approx. 210kg
SiloSafe 24 F approx. 245kg

Accessoires:

- Pressure alarm switch



How the SiloSafe 24 works

...during normal operation

1. The dust laden air enters the silo via the product delivery pipe.
2. The displaced air/dust travels through the cartridges in the SiloSafe 24.
3. As the SiloSafe 24 filters this air, dust collects on the outside of the cartridges.
4. Clean air is then exhausted from the top of the unit.

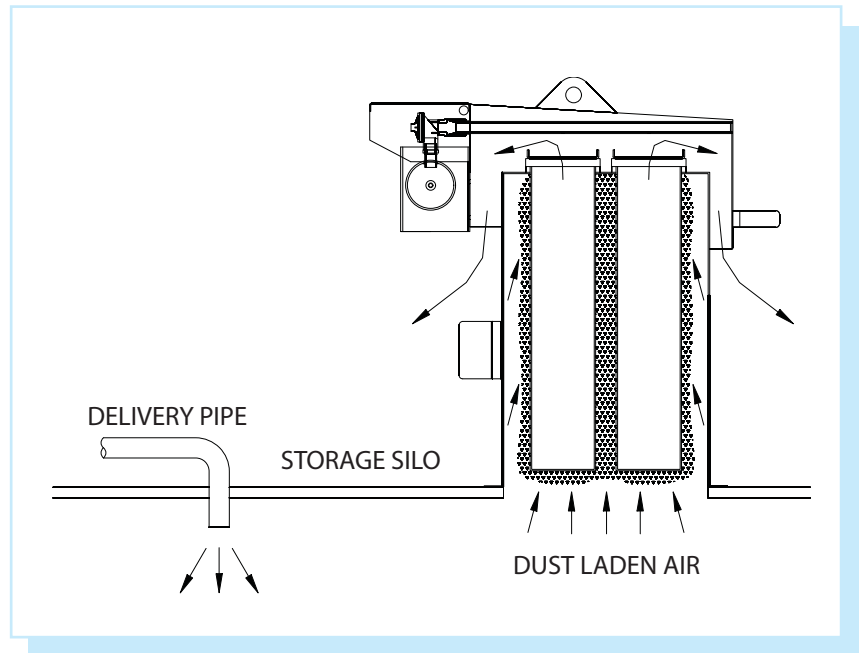

...whilst off-line cleaning

1. The SiloSafe 24 F utilizes a compressed air cleaning system.
2. A compressed air line must be connected to one end of the compressed air manifold.
3. Once the fan is turned off, a solenoid valve opens to allow a pulse of compressed air into the jet tube. The jet tubes are aligned above each cartridge.
4. The downward blast blows the dust off the cartridges (from the inside out) where it falls back into the silo.

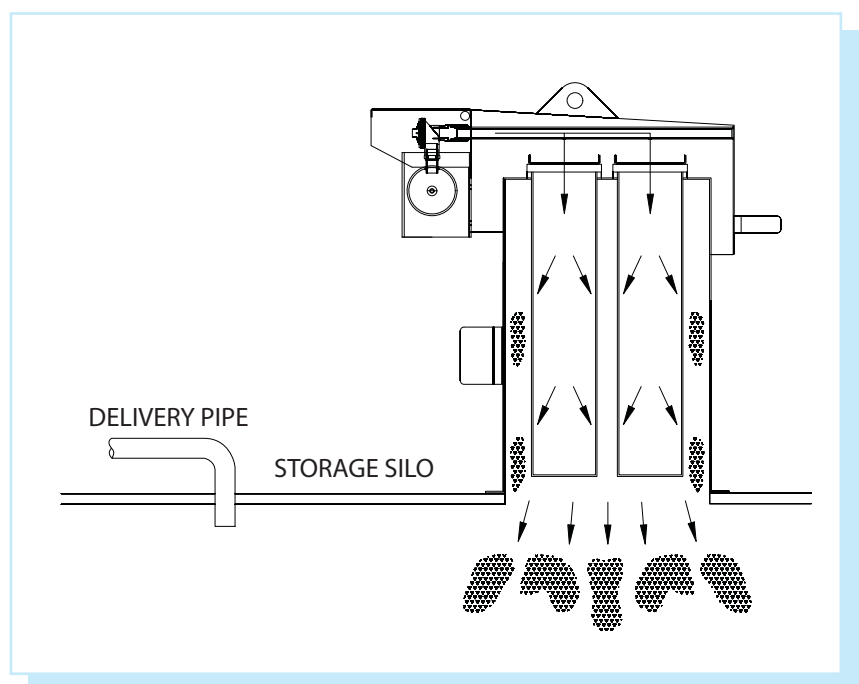



How the SiloSafe 24F Works

...during normal operation

1. The dust laden air enters the silo via the product delivery pipe.
2. The fan (shown dotted) draws the dust laden air through the cartridges of the SiloSafe 24 F.
3. As the SiloSafe 24 F filters this air, the dust collects on the outside of the cartridges.
4. Clean air is then exhausted via the SiloSafe 24 F.

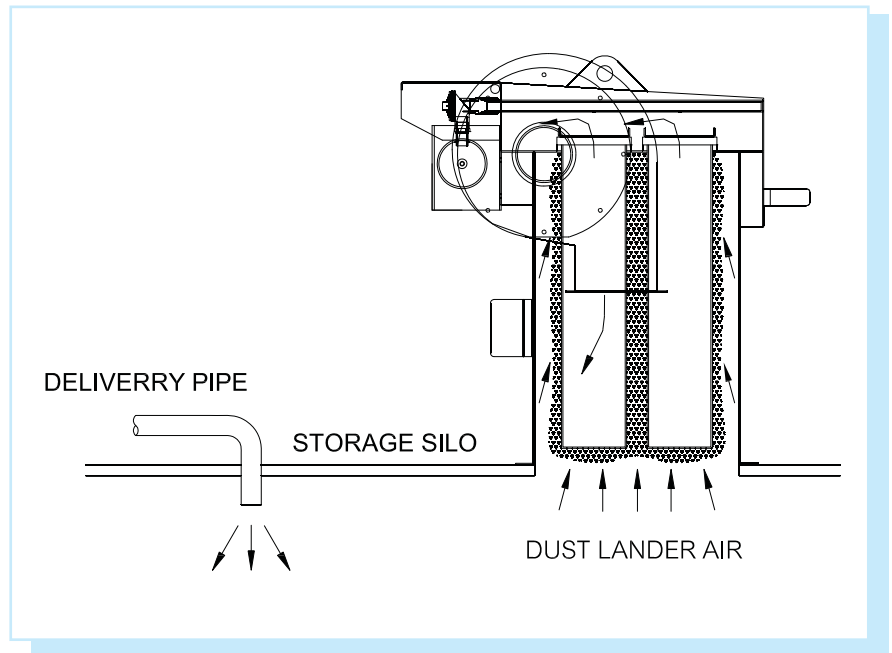

...whilst off-line cleaning

1. The SiloSafe 24 F utilizes a compressed air cleaning system.
2. A compressed air line must be connected to one end of the compressed air manifold.
3. Once the fan is turned off, a solenoid valve opens to allow a pulse of compressed air into the jet tube. The jet tubes are aligned above each cartridge.
4. The downward blast blows the dust off the cartridges (from the inside out) where it falls back into the silo.

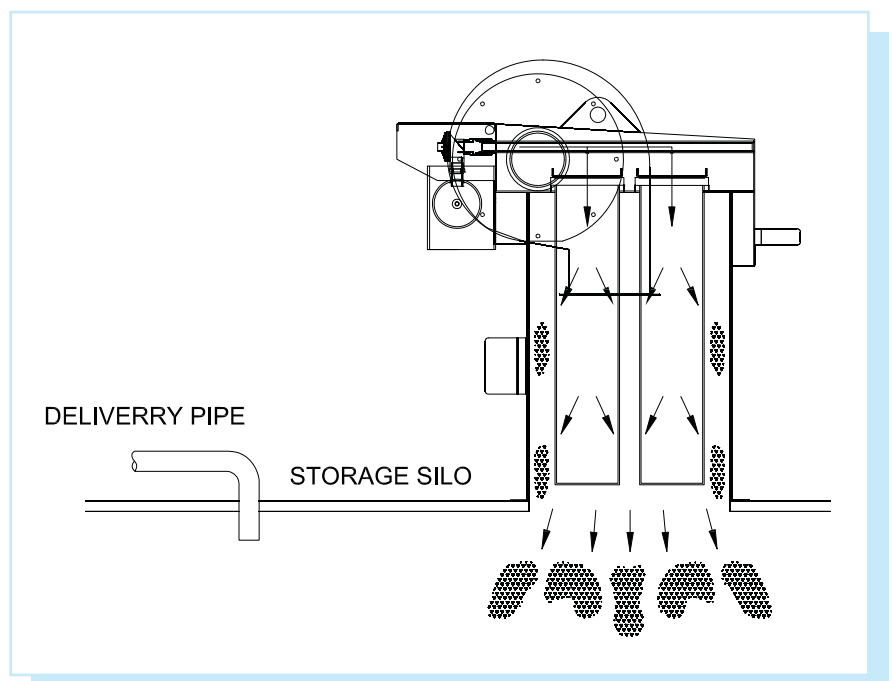

Cartridge Material

At the heart of every SiloSafe cartridge filter is the UniClean Patent pleated cartridge element.



The overall dimensions, including pleat depth and spacing were designed uniquely for SiloSafe.

Years of experience in many applications and the more recent introduction of the UniClean feature ensure maximum performance and long life.

Surface filtration

The filter media is typically around 1.7mm thick but contains many layers of random fibres. Filtration occurs at or very near the surface of the materials and its efficiency (BIA class L, M) is further enhanced by a surface layer of dust.

Filter materials are:

CA100

high quality thermal bonded polyester pleated fabric fitted as standard.

CA140

as CA100 but with metalized antistatic treatment.

CA190

as CA100 but with PTFE treatment for ease of dust release (sticky dust).

Customer Reference



Silo venting system for dust silo, *Foundry Industry*



Pneumatic conveying of cocoa powder, *Food and Beverage Industry*



Silo venting system for additive silo, *Foundry Industry*



Industry we served:

- Aluminium
- Agriculture
- Casting
- Cement
- Chemicals
- Electronics
- Food processing
- Foundry
- Metal & Casting
- Machinery
- Packaging
- Painting
- Paper
- Plastic
- Pharmaceutical
- Rubber
- Shot blast
- Steel
- Tobacco
- Wood production
- Wood processing
- ... and many more



FACTS ABOUT NEDERMAN

The Nederman Group is one of the world's leading suppliers of products and solutions within the environmental technology sector, focusing on industrial air filtration and recycling.

Nederman products and solutions contribute to reducing environmental impacts from industrial production and to creating safe and clean working environments whilst boosting production efficiency.

The group's offering covers everything from the design stage through to installation, commissioning and servicing. Nederman has subsidiaries in 29 countries and agents and distributors in over 30 countries.

Nederman is ISO 9001 and 14001 certified. The group develops and produces in its own manufacturing and assembly units in Europe, North America and Asia.

In 2010 Nederman acquired Dantherm Filtration, thereby forming the world's leading group within industrial air filtration.

Nederman

www.nederman.com

Nederman S.E.A. Co., Ltd.

66/1 Moo 11 Bangkruay-Sainoi Road, T. Bangbuathong, A. Bangbuathong, Nonthaburi 11110, Thailand.

Phone: +66 2715 1300 Fax: +66 2715 1301 Email: info.th@nederman.com

Vietnam Representative Office in Ho Chi Minh City: Phone: +84 835 265 541 Fax: +84 835 265 541 Email: info.vn@nederman.com

Nederman (Malaysia) Sdn. Bhd. (892768-T): Phone: +603 8940 1192 Fax: +603 8940 1196 Email: info.my@nederman.com

Indonesia Representative Office: Phone: +62 815 1499 7996 Fax: +62 815 1499 7996 Email: info.id@nederman.com

Nederman Sales companies in: Australia, Austria, Belgium, Brazil, Canada, China, Czech Rep. Denmark, France, Germany, Hungary, India, Ireland, Malaysia, Northern Ireland, Norway, Poland, Portugal, Romania, Russia, Slovak Republic, Spain, Sweden, Thailand, Turkey, United Kingdom, USA, Vietnam

Nederman Agents in: Bulgaria, Cyprus, Egypt, Estonia, Finland, Greece, Holland, Hongkong, Iceland, Iran, Ireland, Italy, Japan, Korea, Latvia, Lithuania, Malaysia, New Zealand, Philippines, Saudi Arabia, Serbia, Singapore, Slovenia, South Africa, Switzerland, Taiwan R.O.C, Thailand, Turkey, United Arab Emirates