

MHVF Filter

High vacuum filter used in application with a working vacuum of max. 40.000 Pa.



MHVF-1800-C-L

The MHVF filter is a high vacuum filter used in applications with a working vacuum of max. 40.000 Pa.

The MHVF filter can be used in applications where there is a high content of dry dust particles.

Description

The filter is made in galvanised steel sheet and modular elements which makes it a very competitive alternative to other high vacuum filters.

The filter can be supplied with either cartridges or cassettes depending on the air flow, the dust type and the dust concentration. Many of the sizes are available in two different heights.

The cartridges/cassettes are cleaned automatically by a high-efficiency, low energy consuming compressed air valve system activated by an integral electronic controller.

The MHVF filter is easy to maintain due to the following features:

- inspection and change of the filter elements can take place within a few minutes
- easy access for service of the cleaning valves, the controller, the compressed air tank and the filter elements

MHVF - XXX - Y - Z

Mecanova High Vacuum filter

Filter house diameter mm

C: Cartridge; K:Cassette

Height of filter element L or A

| Filter type | Filter area (m ²) cartridge* | Filter Cartridge | Height (H) of filter with bin (mm) | Bin size (liter) | Inlet/outlet diameter (d) |
|---------------|---|---------------------|--|---------------------|------------------------------|
| MHVF-1300-C-L | 32 | 8 UniClean type 40 | 3085 | 50 | Ø250 |
| MHVF-1300-C-A | 53 | 8 UniClean type 66 | 3600 | 50 | Ø315 |
| MHVF-1800-C-L | 64 | 16 UniClean type 40 | 3430 | 50 | Ø315 |
| MHVF-1800-C-A | 106 | 16 UniClean type 66 | 3950 | 50 | Ø400 |

* UniClean cartridge type CA 175 : Filter area approx 2,2 x the table area.

| Filter type | Filter area (m ²) | Filter element | Height (H) of filter with bin (mm) | Bin size (liter) | Inlet/outlet diameter (d) |
|-----------------|-------------------------------|-----------------------|------------------------------------|------------------|---------------------------|
| MHVF-1300-K-L-4 | 15 | 2 cassettes 4 rows | 3085 | 50 | Ø250 |
| MHVF-1300-K-L-6 | 22 | 2 cassettes 6 rows | 3600 | 50 | Ø250 |
| MHVF-1800-K-L-4 | 30 | 4 cassettes 4 rows | 3430 | 50 | Ø315 |
| MHVF-1800-K-L-6 | 44 | 4 cassettes 6 rows | 3950 | 50 | Ø315 |

Specifications

By ordering, please specify filter type and

- filter version
 - Non-explosive dust
 - Explosive dust#
- hopper type
 - bin, standard or large
 - hopper w. outlet type FM (295x295 mm²)
- filter element type
 - UniClean cartridge#
 - Cassette#
- controller type DFC-08M# or no controller

Accessories

- Mecanova high vacuum unit MHVS#
- Large bin, 1300/1800 = 100 litre
- Rotary valve
- Double flap out feeding device#
- Support structure (please specify dimensions)

Please consult separate technical leaflet.

Dimensions

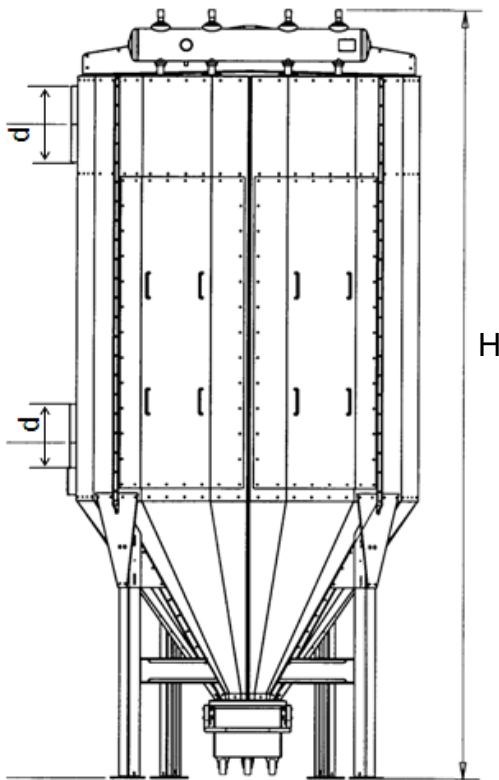

MHVF-1300 or 1800.

Inlet-outlet tangential above each other to the left side seen from door front.

Alternative positions:

MHVF-1300: 6 steps each 60 dgr.

MHVF-1800: 7 steps each 51,4 dgr.

(Front door(s) cannot be used for inlet / outlet)

Material: Galvanized steel 4 mm

