

MHVZ Filter

The MHVZ filter is a high vacuum filter used in applications with a working vacuum of max. 40.000 Pa. The filter can be used in applications where there is a high content of explosive dust particles.

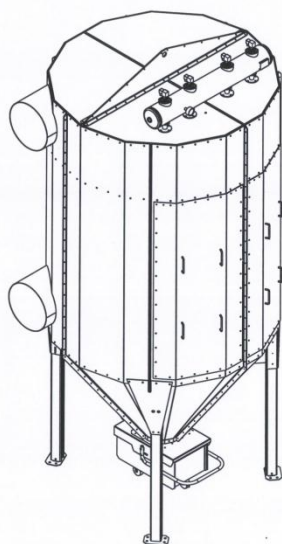

Marking

MHVZ filter body in the St2 version is marked:

Ex II 1(3)/- D St2

The St1 version is marked II 1(3)/- D St1

The St3 version is marked

II 1(3)/- D St3 Kst max 600

The marking is based on evaluation and tests by Nederman.

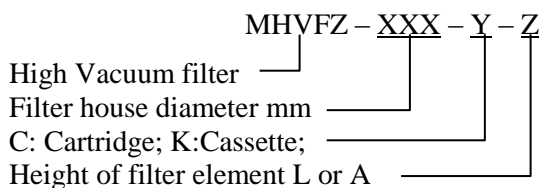

The MHVZ filter is a high vacuum filter used in applications with a working vacuum of max. 40.000 Pa.

The filter is made in galvanized steel sheet which makes it a very competitive alternative to other high vacuum filters.

The MHVZ filter can be used in applications where there is a high content of explosive dust particles.

The filter can be supplied with either antistatic cartridges (UniClean) or antistatic cassettes depending on the air flow, the dust type and the dust concentration. The MHVZ filters can be delivered in two different heights – type L and A.

The Ex-vents are supported on the back side to allow vacuum max 0,3 bar.

The cartridges/cassettes are cleaned automatically by a high-efficiency, low energy consuming compressed air system activated by an integral electronic controller. The MHVZ filter is easy to maintain due to the following features:

- Quick release waste bin
- Inspection and change of the filter elements can take place within a few minutes
- Front service of the cleaning valves, the controller, the compressed air tank and the filter elements.

Ordering

At ordering please specify:

- Dust characteristics Kst and P-Max
- Zone-rating of place for installat. (Nonzone)

Filter type (Bin or rotary valve)	Ex-vent membrane	EX vent St1 Pcs	EX vent St2 Pcs	St3 max bar*m/s	Pred bar	Remark
MHVZ-1300-C/K-L	410x410 mm	1	2	Max 600	0,50	
MHVZ-1300-C-A	410x410 mm	2	2	Max 600	0,50	
MHVZ-1800-C/K-L	410x410 mm	2	2	Max 600	0,50	
MHVZ-1800-C-A	410x410 mm	2	3	Max 600	0,50	

Ex. calculations: according to EN 14491; At one ex-panel: Mounted middle; at 2 or more: One ex-panel mounted at top and at least one at the low position at types 450-800 and at middle position at 1300-1800 types.

St1: Kst 200 bar m/s, Pmax = 9 bar; St2: Kst 300 bar m/s, Pmax = 9 bar; St3: Pmax = 10,5 bar.

Position of ex-panels

MHVZ-450-1300

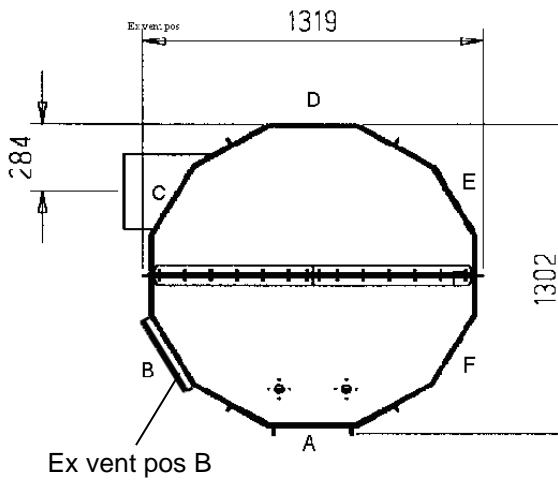

All dimensions are in mm.

MHVZ-1800

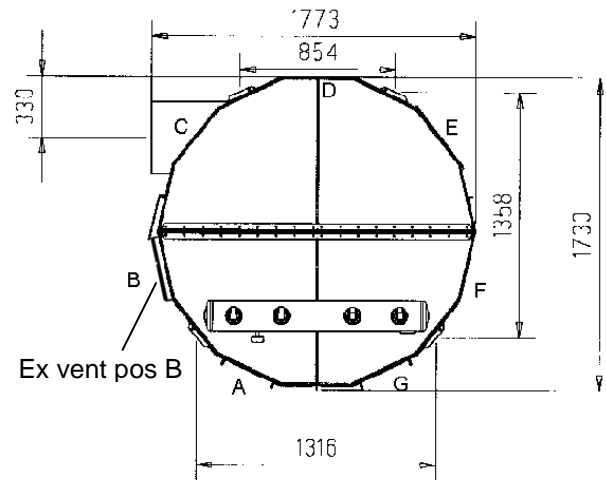

Type	Door position	Standard Ex-vent position	Max Ex-vent above each other	Max number of EX-vents possible
MHVZ-1300-C/K-L	A	B	2*	8
MHVZ-1300-C-A	A	B	3*	12
MHVZ-1800-C/K-L	A+G	B	2*	8
MHVZ-1800-C-A	A+G	B	3*	12

* Lowest ex-panel in inlet level. Not recommended at abrasive dust types