

## FMKZ cassette filter, EX

Modular cassette dust collector, built for continuous use in industrial process filtration and dust collection applications

---

## FMKZ cassette filter, EX



The FMK25 range is a reverse jet cassette dust collector. It was built for continuous use in industrial process filtration and dust collection applications. The FMK dust collector uses our long established fabric pocket cassette that is easily maintained through the front hinged doors. The cassette offers ample filter area and lasts longer than a cartridge.

Air Volume Range: 1.700 to 10.000 m<sup>3</sup>/hr (1,000 to 6,000 CFM)

Independently tested (FMKZ) with ATEX compliant features for explosive dusts  
 Tough galvanised steel construction.  
 Weatherproof for exposed locations.  
 Integral pre-separation chamber  
 All maintenance from unit front  
 Efficient cross flow / down flow inlet air pattern  
 Wide range of integral or remote fans

- The FMK25 range is a reverse jet cassette dust collector. It was built for continuous use in industrial process filtration and dust collection applications. The FMK dust collector uses our long established fabric pocket cassette that is easily maintained through the front hinged doors. The cassette offers ample filter area and lasts longer than a cartridge.

Air Volume Range: 1.700 to 10.000 m<sup>3</sup>/hr (1,000 to 6,000 CFM)

- Independently tested (FMKZ) with ATEX compliant features for explosive dusts  
 Tough galvanised steel construction.  
 Weatherproof for exposed locations.  
 Integral pre-separation chamber  
 All maintenance from unit front  
 Efficient cross flow / down flow inlet air pattern  
 Wide range of integral or remote fans
- Building materials manufacture and distribution
  - Building materials manufacture and distribution
  - Processes with light or medium dust loading

Product name	FMKZ cassette filter, EX
Installation	[Indoor], [Outdoor]
Material	Housing in galvanised sheet steel (2 mm)
Suitable for combustible dust	True
Application	[dust], [fumes]
Dustbin volume (gal)	50 or 100 l or whitout
Operating Temperature	-4 to 158 F (-20 to 70 C)
Filter type	[cassette]
Number of filter elements	6
Filter material	Polyester

## FMKZ cassette filter, EX

Control Voltage (V)	230V / 110V
Weight (lbs)	860 (incl. 50l bin excl. fan)



Fumes



Dust



## FMKZ cassette filter, EX

Description	[model]
FMKZ25 - 8E with bin for discharge	FMKZ25-8Eb(6)

## FMKZ cassette filter, EX

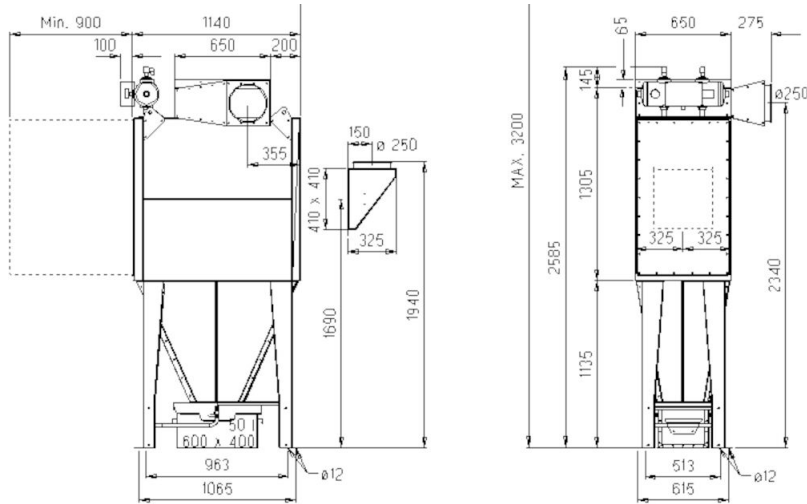

FMK(Z)25-2E Bin

All dimensions in mm.

If 50 liter bin with rollers, add 90 mm.

\* 65 mm to be included at top mounted fan

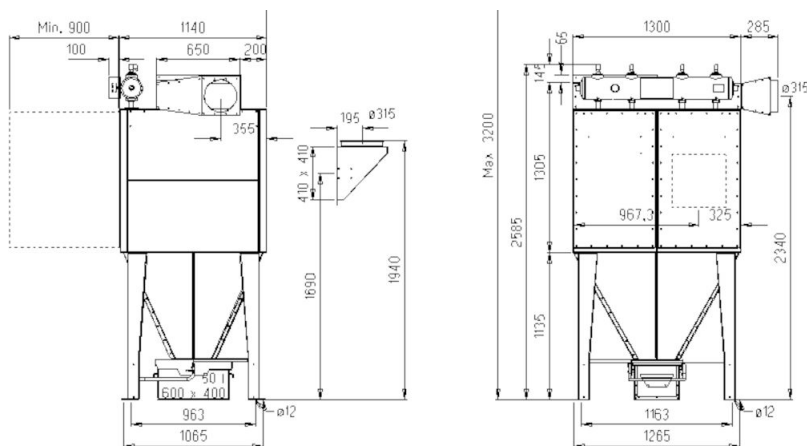

FMK(Z)25-4E Bin

All dimensions in mm.

If 50 liter bin with rollers, add 90 mm.

\* 65 mm to be included at top mounted fan

## FMKZ cassette filter, EX

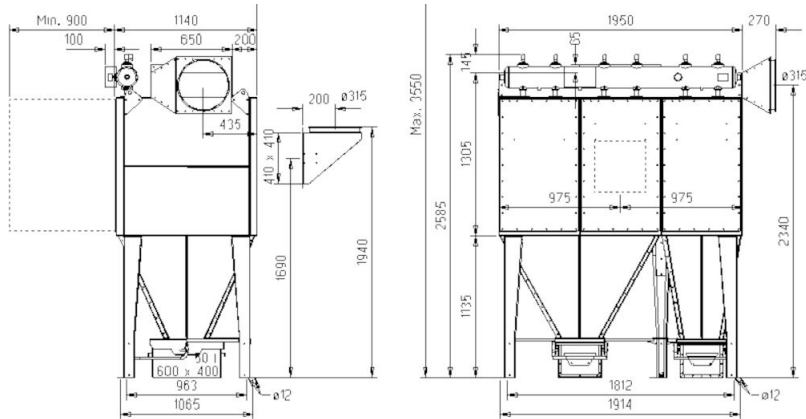

FMK(Z)25-6E Bin

All dimensions in mm.

If 50 liter bin with rollers, add 90 mm.

\* 65 mm to be included at top mounted fan

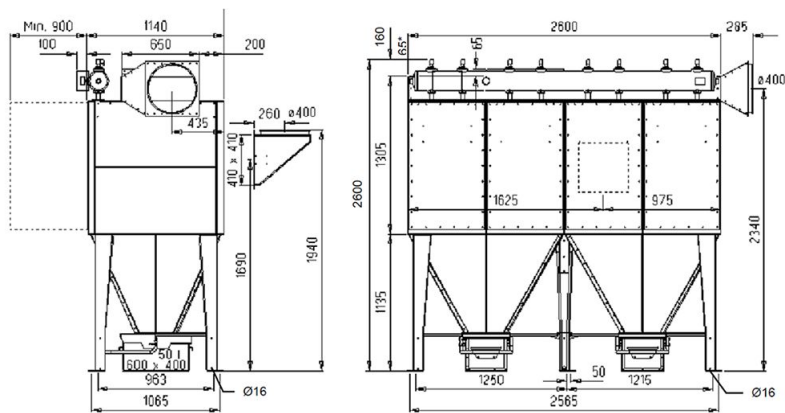

MK(Z)25-8E Bin

All dimensions in mm.

If 50 liter bin with rollers, add 90 mm.

\* 65 mm to be included at top mounted fan

## FMKZ cassette filter, EX

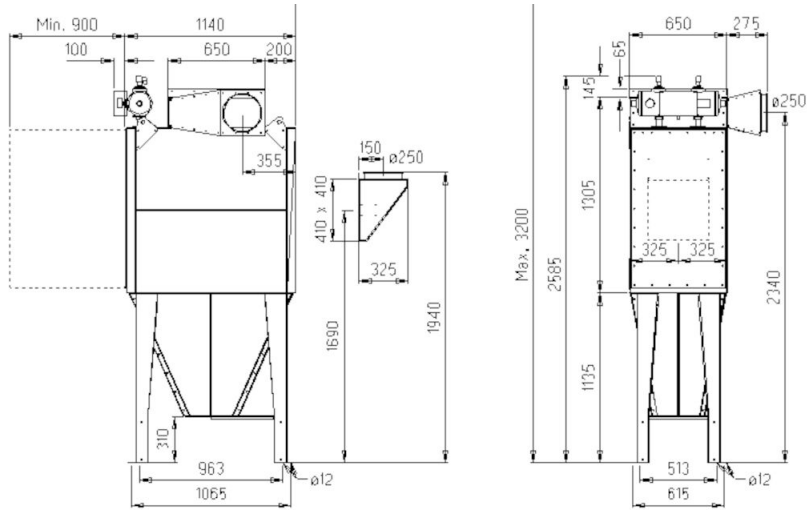

FMK(Z)25-2E Flange

All dimensions in mm.

\* 65 mm to be included at top mounted fan.

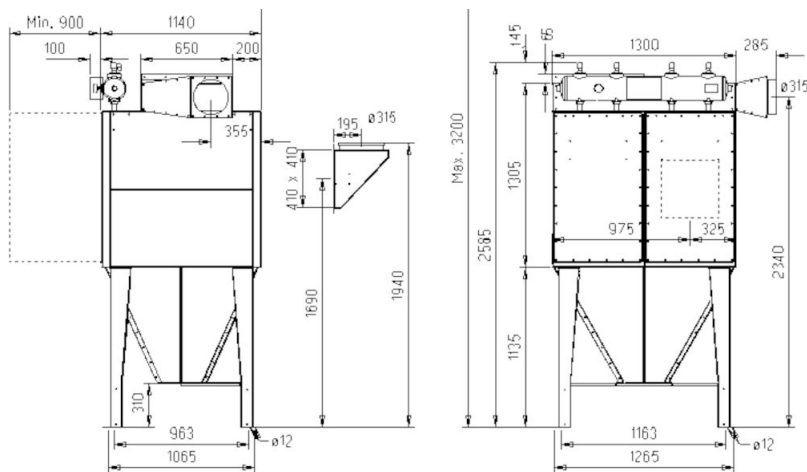

MK(Z)25-4E Flange

All dimensions in mm.

\* 65 mm to be included at top mounted fan.

## FMKZ cassette filter, EX

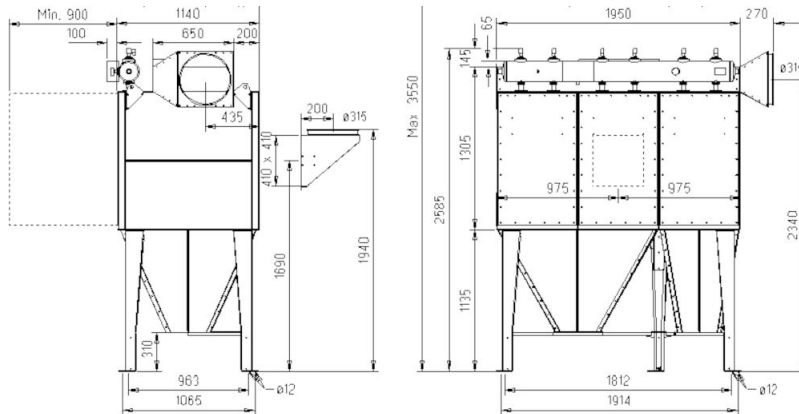

FMK(Z)25-6E Flange

All dimensions in mm.

\* 65 mm to be included at top mounted fan.

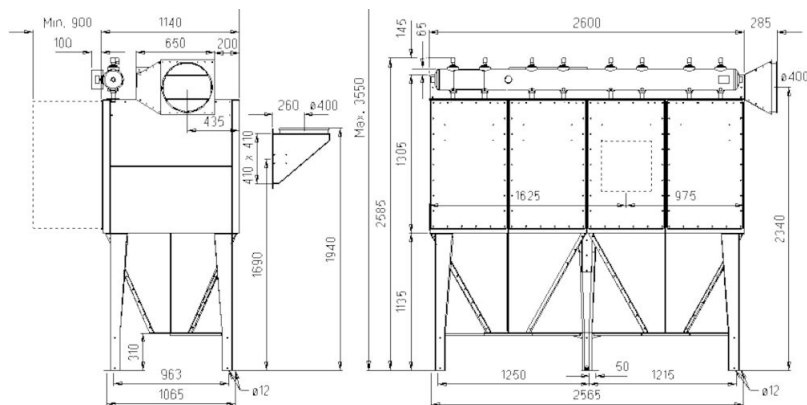

MK(Z)25-8E Flange

All dimensions in mm.

\* 65 mm to be included at top mounted fan.