

NRS 3 rotary valves

Continuous emptying of the dust collector hopper.

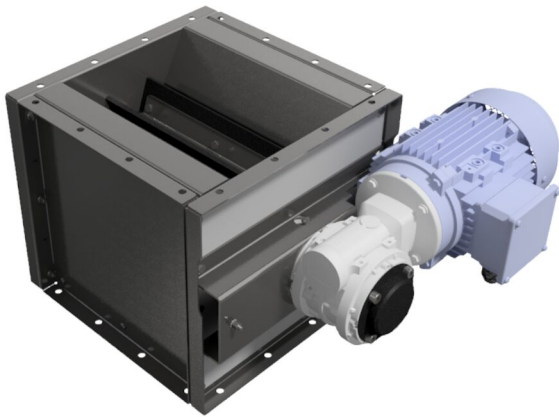

The NRS type rotary valve is used to transfer material between two separate systems. In pneumatic conveying systems, discharge is usually required from the filter or cyclone to the silo, at atmospheric pressure. This is an ideal application for the NRS type rotary valve.

The rotary valve can be used for emptying of several non-adhesive material types. Max. particle size for the NRS3 is 3 x 3 x 10 mm (.1 x .1 x .4 in.).

The rotary valve should not work with highly abrasive dust.

- Robust construction
- Effective air lock between the inlet and outlet provided due to the special rubber blades.

Product name	NRS 3 rotary valves
Noise level (dB(A))	< 70
Installation	Indoor, Outdoor
Material	Galvanised steel plate
Suitable for combustible dust	False
Application	Dust
Operating Temperature	Max. 70°C



Dust

NRS 3 rotary valves

Weight (kg)	Power (kW)	Model
		73009042*
32	0,18	73008861**
40	0,25	73009031**
32	0,18	73009228**

*Without motor

**Capacity at 100% filling - 2,3 m³/h

NRS 3 rotary valves

	Accessory	Part No
	Speed sensor NRS/Z/-3	5507220

NRS 3 rotary valves

Leakage

The leakage of the rotary valve during shutdown (S) and during operation (R) depends on the pressure drop over the rotor. See the diagramme.

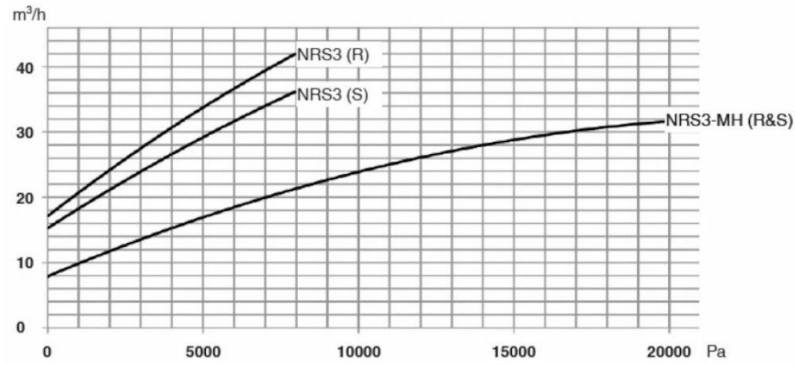

Dimensions NRS 3 / NRSZ 3

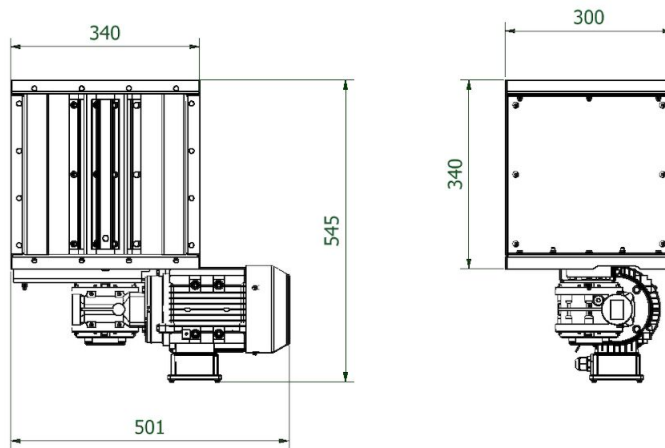

Dimensions NRS 3

NRS 3 rotary valves

Dimension inlet NRS 3 / NRSZ 3

