

BenchTop Extraction Arm FX2 100 ESD/EX

The best and most cost-efficient solution for extraction of hazardous airborne contaminants, in applications where small, flexible and easy-to-use arms are required.









Nederman FX2-armer er laget av lette, anodiserte aluminiumsprofiler med to eller tre justerbare friksjonsledd i kompositt. Styrke og holdbarhet i kombinasjon med lett justering gjør de velegnet i mange miljøer. Spesielt egnet for bruksområder hvor små, fleksible og brukervennlige armer er ønskelig. Armen er utviklet for bruk i elektroniske miljøer der det er fare for elektrostatiske utladninger. ESD/EX-modellen kan også brukes for visse applikasjoner i eksplosjonsfarlige områder. Anbefales for bruk i sone 1,2, 21 og 22

- Optimal efficiency and low noise provides safe and quiet working environment
- Ceilings, walls and floors or fixed to worktops mountings and cut2fit extension profile gives maximum installation flexibility
- The two outermost arm joints can rotate and swivel through 360°, which gives the unique maneuverability
- The lean, smooth and aesthetic design allows arms to fit in well in any environment without compromising its durability and reliability
- Highly integrated products that save customers' time and costs, as well as providing the reliability and functionality to deliver a better performance

Produktnavn	BenchTop Extraction Arm FX2 100 ESD/EX
Støynivå (dB(A))	62 dB(A) at 450 m ³ /h
Installasjon	Innendørs
Materiale	Rør i eloksert aluminium. Leddene i ledende PP plast Kanal tilkobling i ledende EPDM gummi Minihette i ledene PP plast
Damptemperatur	max 70°C
Ekstraheringsarm, diameter (mm)	100
Luftstrøm (m ³ /t)	200 - 450



BenchTop Extraction Arm FX2 100 ESD/EX

Bilde	Navn på datablad	Armlengde (m)	Farge	Vekt (kg)	Model
	FX2-ESD/EX-D100-L1200- Up/Down-Low	1,2	Aluminum and black	4,8	70606544*
	FX2-ESD/EX-D100-L1200- Up/Down-Through	1,2	Aluminum and black	4,1	70606744*
	FX2-ESD/EX-D100-L1800- Up-Low	1,8	aluminum adn black	5,9	70606844**
	FX2-ESD/EX-D100-L1800- Down-Low	1,8	Aluminum and black	5,9	70607044***
	FX2-ESD/EX-D100-L1800- Down-Through	1,8	Aluminum and black	5,2	70607144****
	FX2-ESD/EX-D100-L2400- Up-Low	2,4	Aluminum and black	6,9	70607244**



*Up/Down-Low

**Up-Low

***Down-Low

****Down-Through

BenchTop Extraction Arm FX2 100 ESD/EX

	Tilbehør	Artikkelnummer
	FX-Brakett kit-D50 / 75/100-L190.	70501144
	FX2-Brakettsett-D50/75/100-L500	70377042
	FX2-Bench brakett kit-D50 / 75/100	70501444
	FX-Classic brakett-D50 / 75/100	70501244
	FX-Cut2fit extension-L1100.	70501344
	FX-Cut2fit extension-L2200.	70374600
	FX-Tak dekkplate	70502644
	FX2-Tak dekkplate-PLUS	70377045
	FX2-Vegg BRKT-sett-Flat-L190-Svart	70377044
	FX-Dome hette-ESD / EX-D50 / 75/100.	70376983
	FX-Combi hette-ESD / EX-D50 / 75/100.	70500244
	X-Metal hette-ESD / EX-D50 / 75/100	70500544
	FX-Flenshette-ESD/EX-D50/75/100	70502944
	FX2-Duct connector-ESD/EX-D100	70377041
	FX2-Al kanal-L1000-D75/100 til D100	70377058
	FX2-Al kanal-L2000-D75/100 til D100	70377059
	FX-Slange-ESD-D100-L3000-Svart- Fleksibel slange i svart, elektrisk ledende PE-plast med en diameter på 100 mm og en lengde på 3000 mm. Den skal brukes med støtteing for å koble slangen til armen.	70377102
	FX-Hose-ESD-D125-L5000-Black- Flexible hose in black conductive PE with 125 mm (5 inch) diameter and 5000 mm (195.85 inch) length. It shall be used with hose support ring to connect hose to arm.	70377103
	FX2-Hose support ring-D100	70377068
	FX2-Hose support ring-D125	70377069

BenchTop Extraction Arm FX2 100 ESD/EX

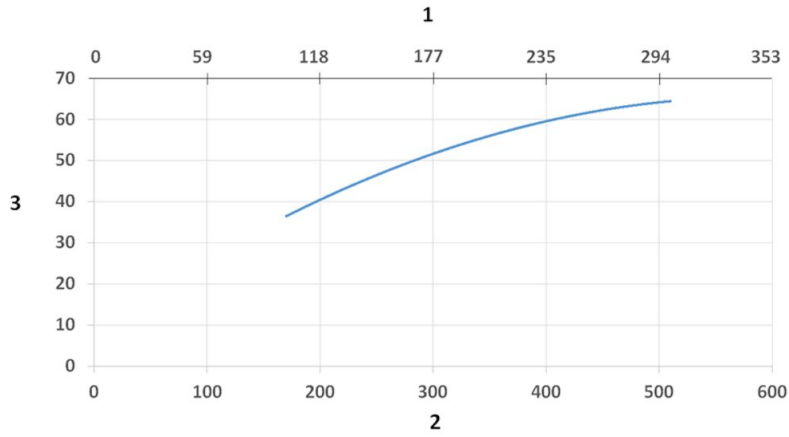

Sound Level diagram:

1) X- Axis: Air Flow Rate (cfm)

2) X- Axis: Air Flow Rate (m/h)

3) Y-Axis: Sound Pressure Level (dB) (A)

BenchTop Extraction Arm FX2 100 ESD/EX

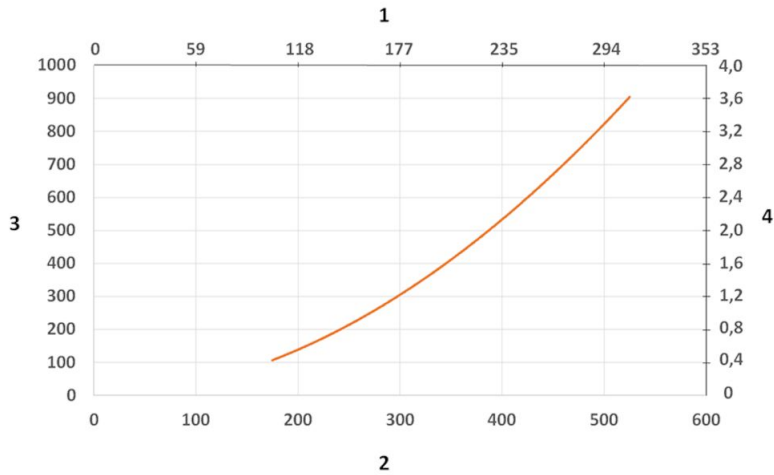

Pressure Drop diagram:

- 1) X- Axis: Air Flow Rate (cfm)
- 2) X- Axis: Air Flow Rate (m/h)

- 3) Y- Axis: Static Pressure Drop (Pa)
- 4) Y- Axis: Static Pressure Drop (in. wg.)

BenchTop Extraction Arm FX2 100 ESD/EX

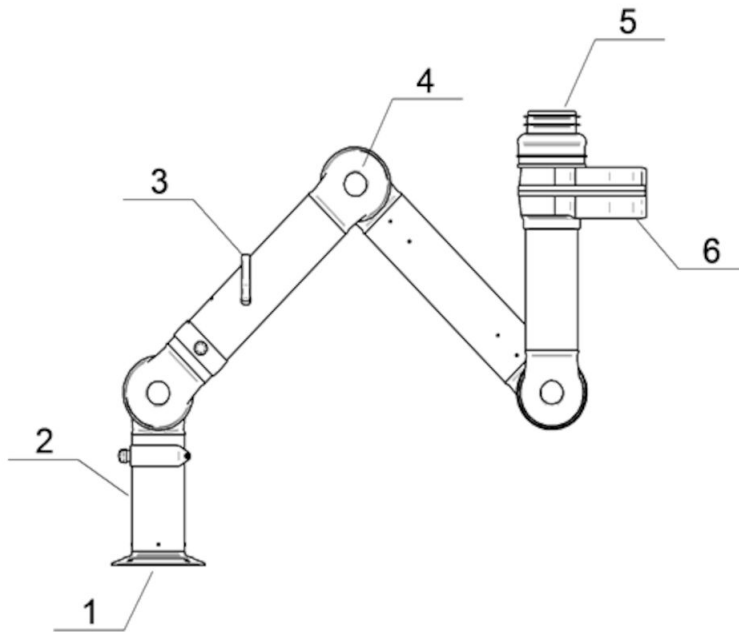

Material:

1) Flange: Conductive PP plastic

2) Tubes: Aluminum, anodized 10 µm

3) Damper adjustment handle: Aluminum: anodized 10 µm
Internal spring: Stainless steel
Damper blade: Conductive TP & PP plastic

4) Joints conductive: PP plastic with glass fibre reinforcement
Plastic rings conductive: PP plastic with glass fibre reinforcement
Axial locking rings conductive: PP plastic with glass fibre reinforcement
Adjustment knobs: PA & EDS plastic
Threaded shaft inside joints: Stainless Steel

5) Duct connector: conductive EPDM Rubber

6) Swivel: Aluminum, conductive powder coating
Rivets: Aluminum
Bearings swivel conductive: PP plastic with glass fibre reinforcement

BenchTop Extraction Arm FX2 100 ESD/EX

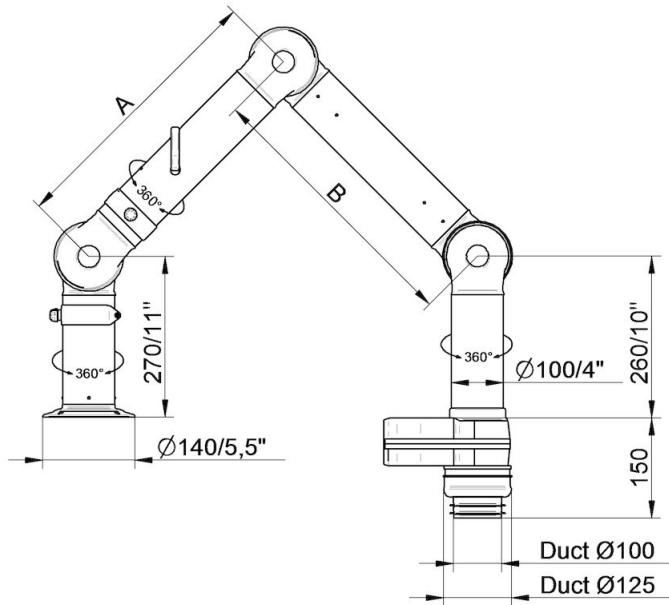

- FX2-ESD/EX-D100-L1200-Up/Down-Low
Delenummer: 70606544
Maks. arbeidsradius: 1170 mm (46,1 in)
A: 450 mm (17,7 in)
B: 450 mm (17,7 in)

- FX2-ESD/EX-D100-L1800-Down-Low
Delenummer: 70607044
Maks. arbeidsradius: 1770 mm (69,7 in)
A: 750 mm (29,5 in)
B: 750 mm (29,5 in)

BenchTop Extraction Arm FX2 100 ESD/EX

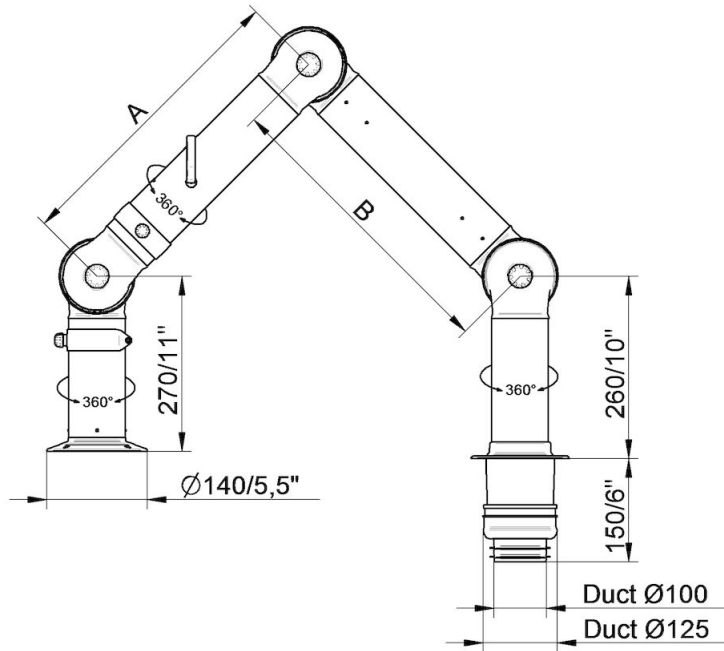

- FX2-ESD/EX-D100-L1200-Up/Down-Thru
 Delenummer: 70606744
 Maks. arbeitsradius: 1170 mm (46,1 in)
 A: 450 mm (17,7 in)
 B: 450 mm (17,7 in)

- FX2-ESD/EX-D100-L1800-Down-Through
 Delenummer: 70607144
 Maks. arbeitsradius: 1770 mm (69,7 in)
 A: 750 mm (29,5 in)
 B: 750 mm (29,5 in)

BenchTop Extraction Arm FX2 100 ESD/EX

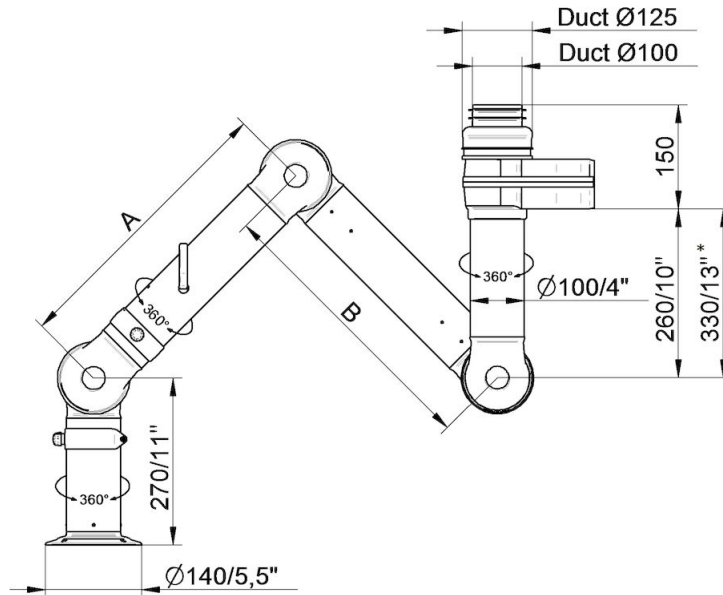

- FX2-ESD/EX-D100-L1200-Up/Down-Low
 Delenummer: 70606544
 Maks. arbeidsradius: 1170 mm (46,1 in)
 A: 450 mm (17,7 in)
 B: 450 mm (17,7 in)

- FX2-ESD/EX-D100-L1800-Up-Low
 Delenummer: 70606844
 Maks. arbeidsradius: 1770 mm (69,7 in)
 A: 750 mm (29,5 in)
 B: 750 mm (29,5 in)

- * • FX2-ESD/EX-D100-L2400-Up-Low
 Delenummer: 70607244
 Maks. arbeidsradius: 2290 (90,16 in)
 A: 1010 mm (39,7 in)
 B: 1010 mm (39,7 in)

BenchTop Extraction Arm FX2 100 ESD/EX

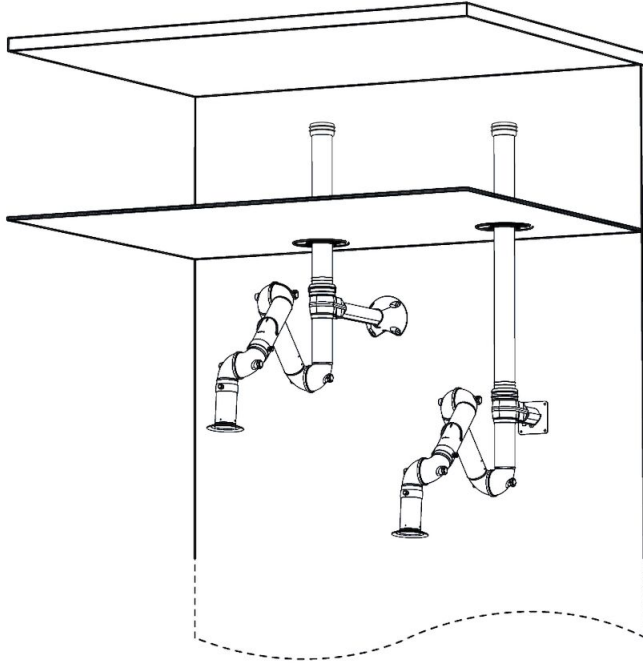

Wall mounting examples:

Left: FX2-Up-Low arm with following accessories:

- FX2-Bracket kit-D50/75/100-L500
- FX2-Ceiling cover plate-PLUS
- FX2-Alu duct
- FX2-Duct connector-ESD/EX-D100

Right: FX2-Up-Low arm with following accessories:

- FX2-Wall BRKT kit-Flat-L190-Black
- FX2-Ceiling cover plate-PLUS
- FX2-Alu duct
- FX2-Duct connector-ESD/EX-D100

BenchTop Extraction Arm FX2 100 ESD/EX

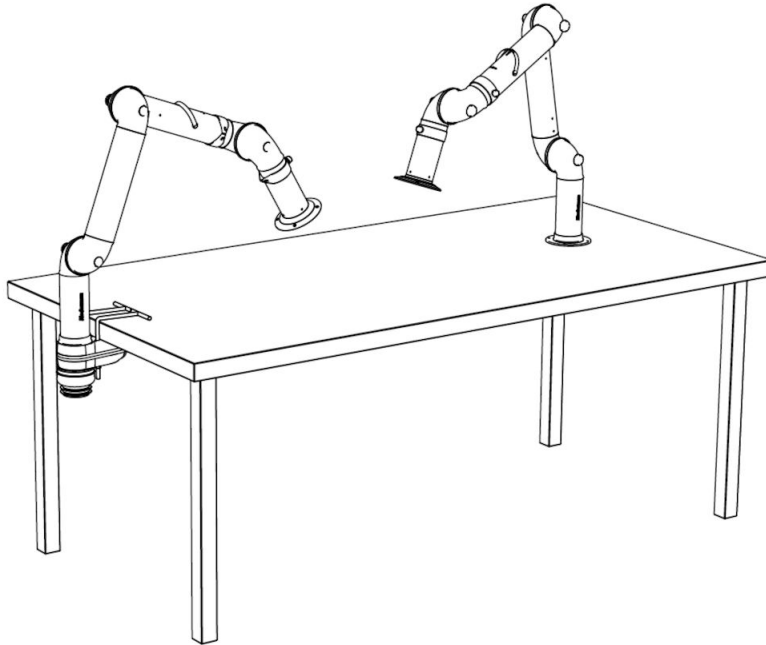

Bench mounting examples:

Left: FX2-Down-Low arm with following accessories:

-FX2-Bench bracket kit-D50/75/100

Right: FX2-Down-Through arm

BenchTop Extraction Arm FX2 100 ESD/EX

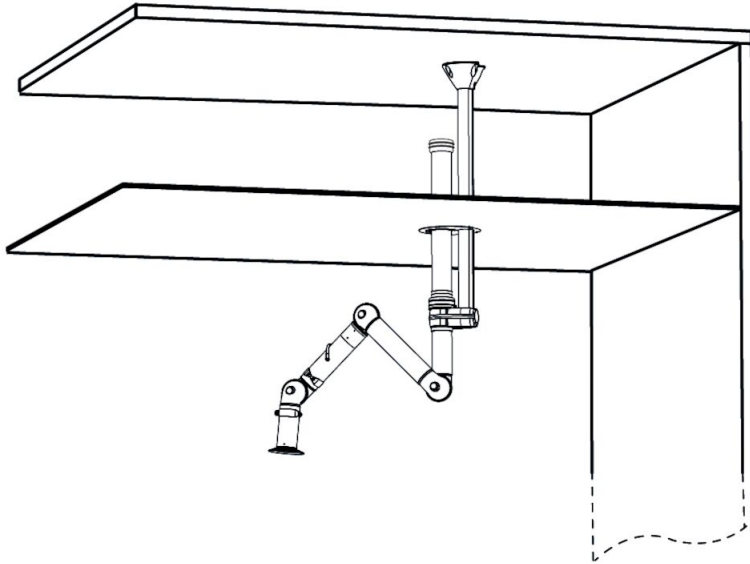

- Ceiling mounting example:
FX2-Up-Low arm with following accessories:
- FX-Classic bracket
 - FX-Cut2fit extension-L1100
 - FX2-Alu duct
 - FX2-Duct connector-ESD/EX-D100
 - FX-Ceiling cover plate

BenchTop Extraction Arm FX2 100 ESD/EX

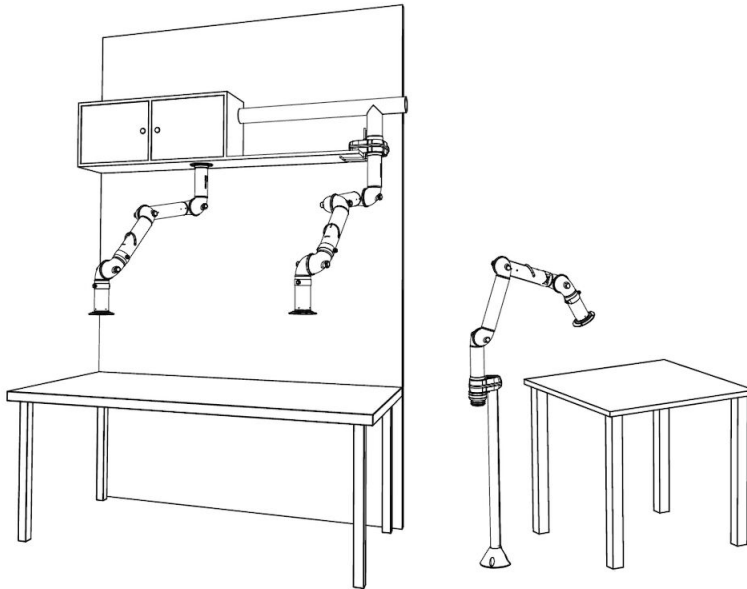

Other mounting examples:

Left: Overbench cabinet mounting with FX2-Up/Down-Through arm

Middle: Shelf mounting with FX2-Up-Low arm and following accessories:

-FX2-Bench bracket kit

Right: Floor mounting with FX2-Up-Low arm and following accessories:

-FX-Classic bracket

-FX-Cut2fit extension-L1100