

Drum filler inlet/outlet d51

Suitable for emptying of oil sumps, oil drums and liquid suction from floors after spillage.

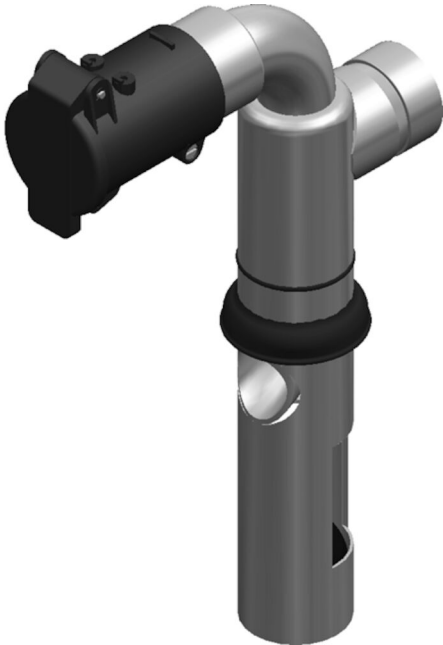

Handy pre-separator for liquids for collection into oil drums. It should be placed in the bung hole (R2") of an empty but suitable oil drum. By connecting the unit to suction hoses, it is ready to use. The built-in float ball stops the suction when the drum is full.

- No filter is needed
- Easy handling
- Drum is not included

Product name	Drum filler inlet/outlet d51
Weight (lbs)	2.9 lbs



Drum filler inlet/outlet d51

Image	Description	Model
	Drum filler inlet/outlet d51	43590001

Drum filler inlet/outlet d51

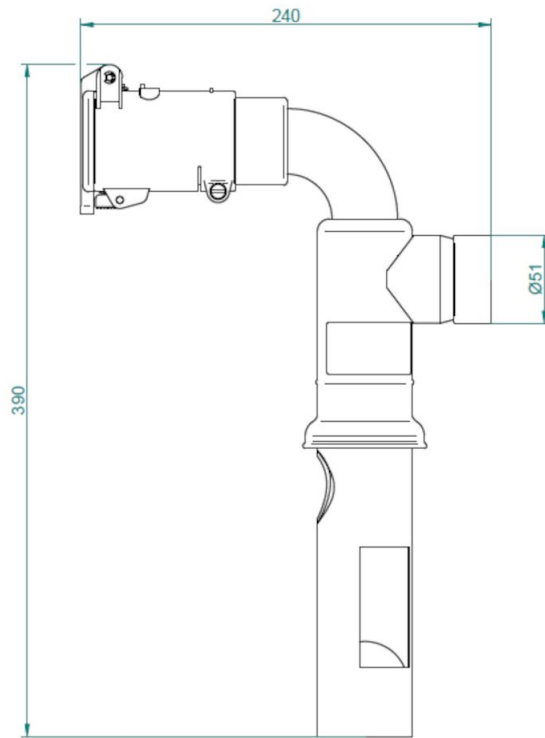

Length x Width x Height: 390 x 240 x 70 mm