

## FE 24/7 2.5

Mobile unit for continuous welding application and for one or two users. Fumes extracted directly at the torch.



The FE 24/7 2.5 is a mobile high vacuum unit designed to extract welding fumes in a continuous basis. Connected to a welding torch with integrated extraction, the FE 24/7 2.5 unit extracts the fumes directly at source for one or two welders. There are two connection points / hose inlets. Automatic filter cleaning, side channel fans with high capacity and all special values that a Nederman product offers. Upgrade with automatic start/stop function is available for user-friendly operation and improved energy efficiency. The unit comes with 5m electric cable with CEE plug.





- Fumes are extracted efficiently during long shifts of welding thanks to the continuous run, efficient and maintenance-free side channel blower.
- Easy adjustment of air flow depending on application improves productivity and energy efficiency.
- Efficient and automatic filter cleaning assures long filter life for low operating cost.
- Integrated spark trap protects the FE 24/7 from sparks and minimizes the risk of damages to the filter cartridge.
- Filtered air can be re-circulated even when particulates are from high alloy steel. The unit is W3 approved (EN 15012).

Nom du produit	FE 24/7 2.5
Niveau sonore (dB(A))	73
Efficacité de filtration (%)	99
Installation	Intérieur
Matériel	Sheet metal
Méthode de décolmatage	[CompressedAir]
Application	Fumée
Pression de fonctionnement (kPa)	37,5
Débit max (m <sup>3</sup> /h)	270
Surface filtrante (m <sup>2</sup> )	5

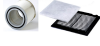

FE 24/7 2.5

## FE 24/7 2.5

	[accessory]	[partno]
	Silencieux de buse CWN-S 105/50L, raccord D=50 mm, débit d'air 250 m³/h	55999414*
	Coupleur de ligne BC50-50-50 pour deux utilisateurs	55999420
	Replacement filter cartridge (incl. small filter and plastic bag)	55999430
	Filter for bypass cooling air (set of 5 pcs)	55999431
	Plastic bag for dust bin, 10 pcs	55999432
	Blanking plates FE24/7	55999436

\*Buse amortisseur de bruit avec extension en acier flexible. Pour montage sur bras articulés, base aimant ou aspiration.

## FE 24/7 2.5



Accessories configuration for one user, 45mm welding machine connection.

- (1) Hose Coupler M50-44P, art.no. 55999418
- (2) Hose Superflex Ø45mm Black 5m, art.no. 55999411
- (3) Nozzle TM-200 Funnel, art.no. 55999413
- (13) Sensor Clamp with plug for automatic start/stop, art.no. 55999410

## FE 24/7 2.5

Accessories configuration for one user, 50 mm connection:

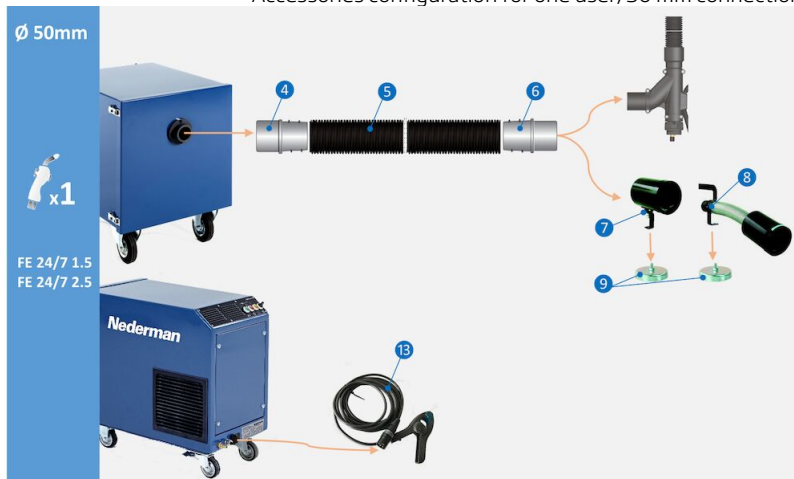

Accessories configuration for one user, 50mm welding machine connection.

- (4) Hose Coupler M50-50P, art.no. 55999416
- (5) Hose PE-51 L=5m, art.no. 55999412
- (6) Hose Coupler F50-50P, art.no. 55999417
- (7) Nozzle CWN-S 105/50 Silencer, art.no. 55999415
- (8) Nozzle CWN-S 105/50L Silencer, art.no. 55999414
- (9) Magnetic foot for nozzle CWN-S, art.no. 55999419
- (13) Sensor Clamp with plug for automatic start/stop, art.no. 55999410

Accessories configuration for two users, 45 mm connection:

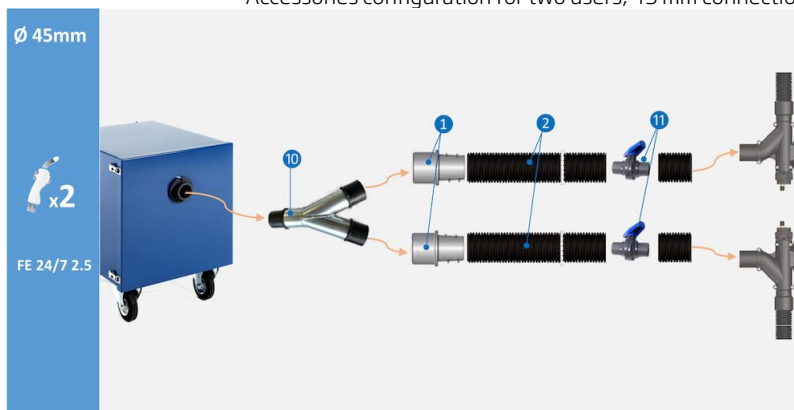

Accessories configuration for two users, 45mm welding machine connection.

- (10) Branch 50/50/50, art.no. 55999420
- (1) Hose Coupler M50-44P, art.no. 55999418
- (2) Hose Superflex Ø45mm Black 5m, art.no. 55999411
- (11) Ball valve 44mm, art.no. 55999422

## FE 24/7 2.5

Accessories configuration for two users, 50 mm connection:

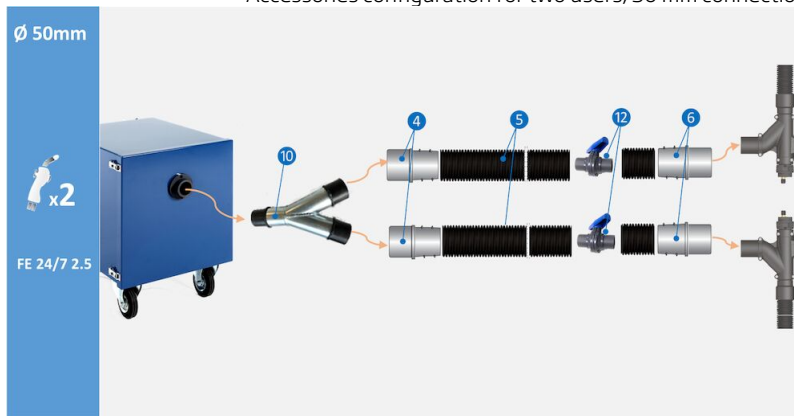

Accessories configuration for two users, 50mm welding machine connection.

- (10) Branch 50/50/50, art.no. 55999420
- (4) Hose Coupler M50-50P, art.no. 55999416
- (5) Hose PE-51 L=5m, art.no. 55999412
- (12) Ball valve 51mm, art.no. 55999421
- (6) Hose Coupler F50-50P, art.no. 55999417

