

FA 7 Pre-separator

For separating liquids and objects.



The Nederman FA7 unit separates liquids and objects to prevent them from going into a stationary piping system. The FA7 pre-separator is idealic in vehicle repair shops, metal fabrication industries and wherever scraps of glass, metal and other coarse materials need to be removed. FA7 is also perfect for picking up water and cutting fluids.

- Captures coarse materials preventing clogs in the piping system.
- Less wear on piping system.
- Cyclone inlet for efficient pre-separation

Product name	FA 7 Pre-separator
Dustbin volume (gal)	70
Capacity (max airflow m ³ /h)	400 (m ³ /h)
Inlet	2" female (KV50)
Weight (lbs)	88
Outlet	2" male alt. 4"



FA 7 Pre-separator

[model]
40110140

FA 7 Pre-separator

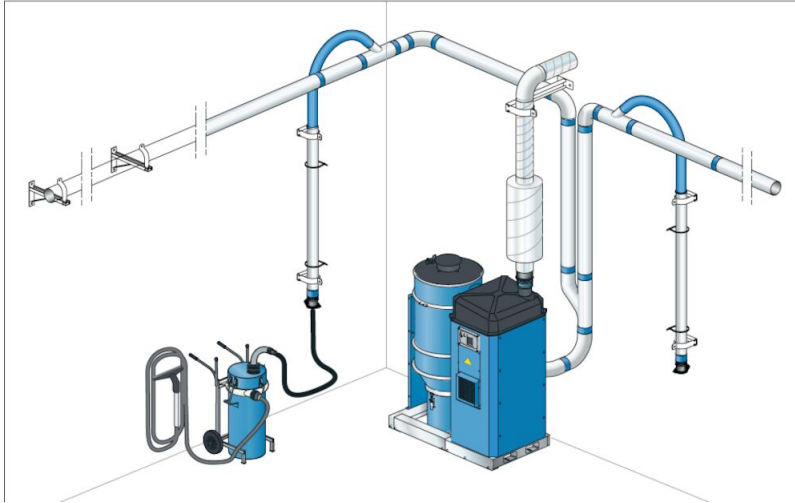

The Pre-separator FA7 can be connected to a Nederman stationary vacuum units FlexPAK or E-PAK.

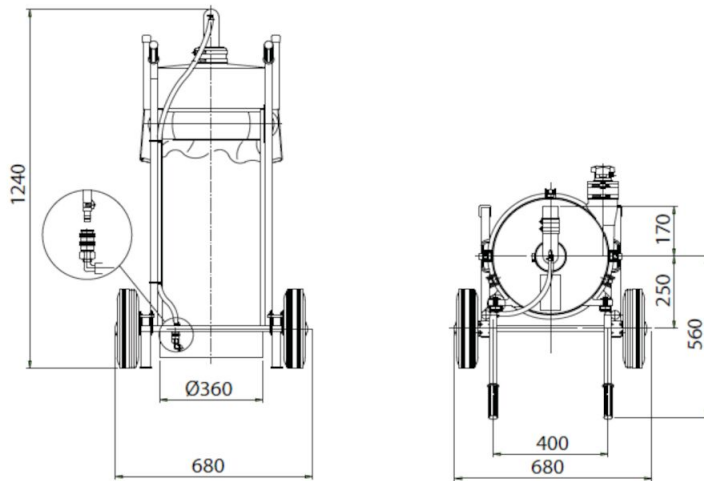

Dimensions FA7 70 liter.