

Klapventil til eksplosionsisolering type CARZ

Klapventil til eksplosionsisolering CARZ - dit beskyttelsessystem til brændbare støvapplikationer



Klapventil til eksplosionsisolering type CARZ forhindrer transmission af eksplosionstrykbølge og flammer fra filteret i at sprede sig til dit arbejdsområde. Ved at anvende CARZ klapventil til eksplosionsisolering reducerer du risikoen for en støvekspllosion til gavn for både mennesker og udstyr.

Funktion

Under normal drift holdes klappen åben. Den store åbningsvinkel på klappen sikrer et lavt trykfald. I tilfælde af en eksplosion i filteret tvinger trykbølgen klappen til at lukke og og fastlåse denne. Når klapppladen er lukket, udgør den en effektiv barriere for evt. flammer. Dette forhindrer eksplosionen overføres fra filteret til dit arbejdsområde.

Uanset hvilken branche du arbejder i eller hvilken støvtype, der genereres, kan vi levere komplette løsninger til beskyttelse mod støvekspllosioner i filtre og klapventiler til eksplosionsisolering.

- Testet i henhold til gældende standarder og foreskrifter
- I overensstemmelse med de fleste internationale støveksplotionsbeskyttelseskoder (ATEX og NFPA68)
- Det største udvalg af størrelser, applikationer og forskellige filter applikationer på markedet (inkl. godkendelse af systemer med over- eller undertryk)
- Fremstillet af Nederman i overensstemmelse med certificeret kvalitetssikringssystem, for at sikre det højeste kvalitetsniveau og pålidelighed

Produkt navn	Klapventil til eksplosionsisolering type CARZ
Materiale	Welded carbon steel, painted RAL5009
Driftstemperatur	-20°C - +70°C (Min 0 F Max 160 F)
Omgivelsernes temperatur	-20°C - +60°C (Min 0 F Max 140 F)
Afklaring af tekniske data	LEL = Lower Explosion Limit = MEC Minimum Explosion Concentration
Eksplosionsklasse ATEX	St1
Max. hastighed i rør (m/s)	30
Min. hastighed i rør	0
Install type	Push and Pull
Støv type	Organisk
Kst (bar m/s)	200
Maximum reduced pressure, Pred (bar)	0,45























Klapventil til eksplosionsisolering type CARZ

Diameter (mm)	Tilslutning	Vægt (kg)	Støvkonzentration i rør	Minimum beholder/filter størrelse, Push (m ³)	Minimum vessel size, pull (m ³)	Model
160	FL	23	Any	0,4	0,4	73001200
180	FL	26	< LEL	0,9	0,9	73001201*
200	FL	29	< LEL	0,9	0,9	73001202*
250	FL	36	< LEL	0,9	0,9	73001204*
315	FL	45	< LEL	0,9	0,9	73001207*
350	FL	50	< LEL	0,9	0,9	73001209*
400	FL	57	< LEL	0,9	0,9	73001211*
160	NW	23	Any	0,4	0,4	73001212
180	NW	26	< LEL	0,9	0,9	73001213*
200	NW	29	< LEL	0,9	0,9	73001214*
250	NW	36	< LEL	0,9	0,9	73001216*
315	NW	45	< LEL	0,9	0,9	73001219*
355	NW	50	< LEL	0,9	0,9	73001221*
400	NW	57	< LEL	0,9	0,9	73001223*
160	QF	23	Any	0,4	0,4	73001224
180	QF	26	< LEL	0,9	0,9	73001225*
200	QF		< LEL	0,9	0,9	73001226*
250	QF	29	< LEL	0,9	0,9	73001228*
315	QF	36	< LEL	0,9	0,9	73001231*
350	QF	45	< LEL	0,9	0,9	73001233*
400	QF	57	< LEL	0,9	0,9	73001235*
160	FL	23	Any	0,4	0,4	73000301
180	FL	26	< LEL	0,9	0,9	73000302*
200	FL	29	< LEL	0,9	0,9	73000303*
250	FL	36	< LEL	0,9	0,9	73000304*
315	FL	45	< LEL	0,9	0,9	73000305*
350	FL	50	< LEL	0,9	0,9	73000306*
400	FL	57	< LEL	0,9	0,9	73000307*
160	NW	36	Any	0,4	0,4	73000308
180	NW	26	< LEL	0,9	0,9	73000309*
200	NW	29	< LEL	0,9	0,9	73000310*
315	NW	45	< LEL	0,9	0,9	73000312*
355	NW	50	< LEL	0,9	0,9	73000313*
400	NW	57	< LEL	0,9	0,9	73000314*
160	QF	23	Any	0,4	0,4	73000315
180	QF	26	< LEL	0,9	0,9	73000316*
200	QF	29	< LEL	0,9	0,9	73000317*
250	QF	29	< LEL	0,9	0,9	73000318*
315	QF	36	< LEL	0,9	0,9	73000319*
350	QF	45	< LEL	0,9	0,9	73000320*
400	QF	57	< LEL	0,9	0,9	73000321*
250	NW		< LEL	0,9	0,9	73000311*

*LEL = Lower Explosion Limit = MEC Minimum Explosion Concentration

Klapventil til eksplosionsisolering type CARZ

	Tilbehør	Artikelnummer
	CARZ låse sensor sæt	73001236
	CARZ support frame suspended 160	73001558
	CARZ support frame suspended 180	73001559
	CARZ support frame suspended 200	73001560
	CARZ support frame suspended 315	73001562
	CARZ support frame suspended 500	73001566
	CARZ support frame suspended 710	73001569
	Carz support frame suspended 900	73001571
	CARZ support frame suspended 1000	73001572
	CARZ stativ vægophæng 160	73001573
	CARZ stativ vægophæng 180	73001574
	CARZ stativ vægophæng 200	73001575
	CARZ stativ vægophæng 250	73001576
	CARZ stativ vægophæng 315	73001577
	CARZ stativ vægophæng 350	73001578
	CARZ stativ vægophæng 400	73001579
	CARZ stativ vægophæng 450	73001580
	CARZ stativ vægophæng 500	73001581
	CARZ stativ vægophæng 560	73001582
	CARZ stativ vægophæng 900	73001586
	CARZ stativ vægophæng 1000	73001587

Klapventil til eksplosionsisolering type CARZ

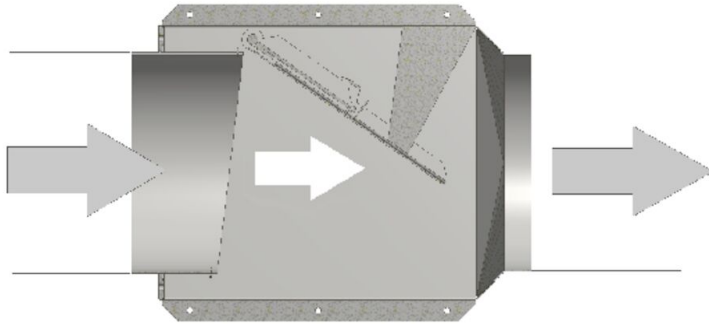

Suction direction

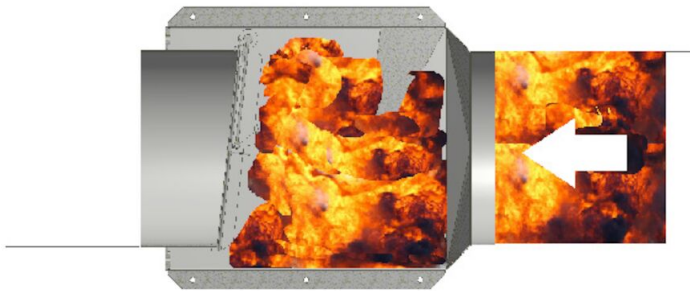

Explosion direction

Klapventil til eksplosionsisolering type CARZ

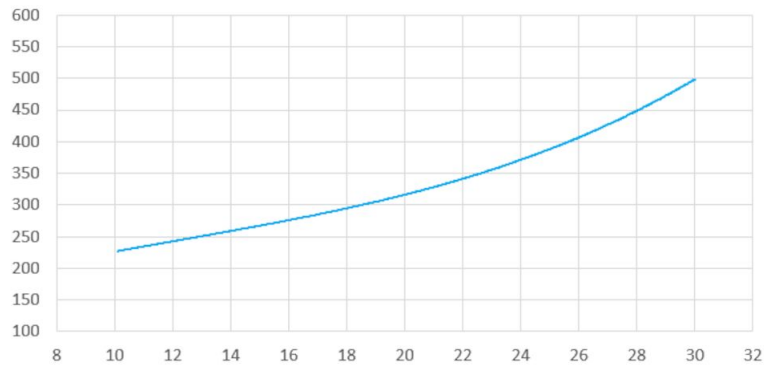
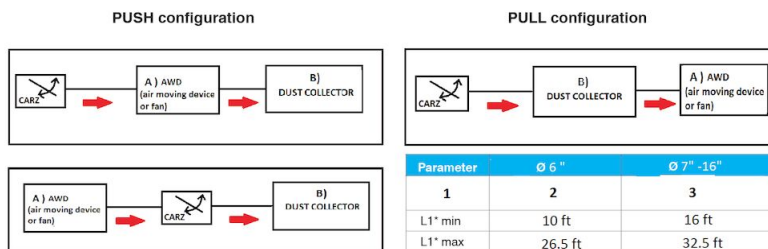

Chart of pressure drop vs. air velocity in duct

Pressure drop CARZ, sizes 160 -400

X- Axis: Air velocity in duct (m/s)

Y-Axis: Pressure drop (Pa)



Push/ Pull configuration, imperial

A) AWD (air moving device or fan)
B) Dust Collector

- 1) Elbows
- 2) Straight duct and max. 2 elbows 90°
- 3) Straight duct and max. 2 elbows 90°

L1 - Installation distance from the vessel, where the explosion could occur, to the CARZ.

Klapventil til eksplosionsisolering type CARZ

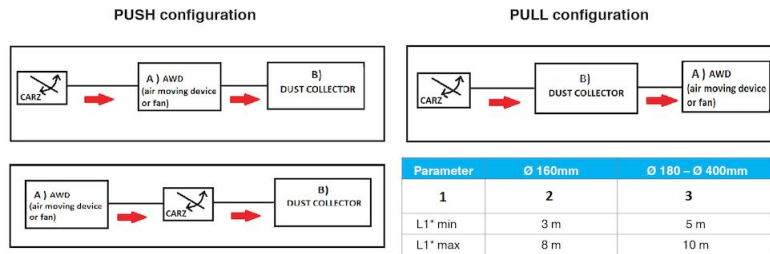

Push/ Pull configuration, metric

A) AWD (air moving device or fan)
B) Dust Collector

- 1) Elbows
- 2) Straight duct and max. 2 elbows 90°
- 3) Straight duct and max. 2 elbows 90°

L1 - Installation distance from the vessel, where the explosion could occur, to the CARZ.

Flap valve size ØD	Dimensions								Weight (lbs)	Part number	
	A (inch)	B (inch)	C (inch)	D (inch)	E (inch)	F (inch)	G (inch)	H (inch)		QuickFit	Flanged
(6")	19.5	18.5	17.1	22.9	7.7	12.2	5.1	6.1	51	73001273	73001261
(7")	20.3		17.9		8.1	11.9	5.5	6.5	57	73001274	73001262
(8")	21.1		18.7	8.5	11.4	5.9	6.9	64	73001275	73001263	
(10")	23.0		20.7	23.0	9.5	10.5	6.9	7.9	79	73001277	73001265
(12,5")	26.0	19.9	24.2	26.0	10.8	9.1	8.4	9.9	104	73001281	73001269
(14")	27.0	20.9	25.2	27.0	11.5	8.5	8.9	10.4	110	73001282	73001270
(16")	28.9	22.8	27.2	28.9	12.4	7.8	9.8	11.5	126	73001284	73001272

Dimension table, Imperial

Flap valve size ØD	Dimensions [mm]								Weight [kg]	Part number					
	A	B	C	D	E	F	G	H		Stainless steel version					
	FL	QF	NW**	FL	QF	NW**	FL	QF		NW**					
160mm	495	470	435	196	310	130	155	23	73001200	73001224	73001212	73000301	73000315	73000308	
180mm	515		455	581	206	301	140	165	26	73001201	73001225	73001213	73000302	73000316	
200mm	535		475	216	291	150	175	29	73001202	73001216	73001214	73000303	73000317	73000310	
250mm	585		525	585	241	266	175	200	36	73001204	73001228	73001216	73000304	73000318	
315mm	650	495	605	650	273	230	213	253	45	73001207	73001231	73001219	73000305	73000319	
350mm*	685	530	640	685	291	217	225	265	50	73001209	73001233	73001221	73000306	73000320	
400mm	735	580	690	735	316	198	250	290	57	73001211	73001235	73001223	73000307	73000321	

Dimensions table, metric

Klapventil til eksplosionsisolering type CARZ

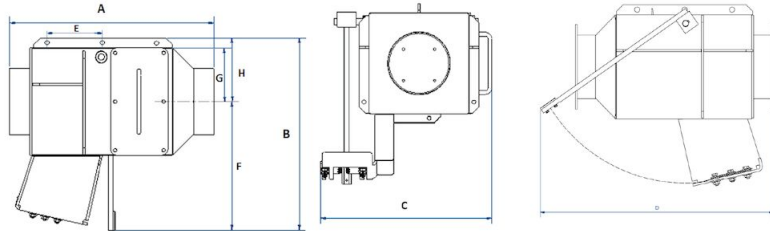

Dimensions