

MEP SmartFilter Ex

MEP SmartFilter Ex er et multifunktions-filtreringssystem. Det kan tilpasses, så det passer perfekt til kundespecifikke krav med en luftstrøm på op til 10.500 m³/time.



MEP SmartFilter EX er et multifunktions-kuvertfiltreringssystem. Det kan tilpasses, så det passer perfekt til kundespecifikke krav. Velegnet til håndtering af forskellige støvtyper og kan anvendes til flere forskellige applikationer som slibning, blæsning og generelt støv. Det modulære design giver mulighed for fritstående løsninger såvel som sammenbygning af filtre til udvidede krav. MEP Ex filteret benytter vores velkendte og velafprøvede stof kuvertfiltre, som let vedligeholdes gennem de fronthængte servicedøre. Kuvertfiltermaterialer for de fleste applikationer forefindes, afhængig af støvtype, støvbelastning og krav til effektivitet. Filteret er konstrueret i 2 mm galvaniseret stålplade, er let at montere, omkostningseffektivt ved forsendelse samt korrosionsbeskyttet. Filteret har lang levetid, hvilket betyder "low cost of ownership". Styling, som er IoT forberedt, med avanceret rensesystem giver optimal systemdrift inklusiv overvågning og kontrol af filteranlægget. Gateway-funktionalitet til "Cloud" kommunikation. MEP SmartFilter Ex har et stort tilbehørsprogram såsom ventilatorer, indløb, affaldsspande, spjæld osv.









- Opnå kontrol over filtreringsydelse med "Insight Analytics", Nederman's unikke overvågningsteknologi.
- Optimeret fodaftryk gennem innovativ kuvertdesign med medium luftgennemstrømning.
- Reduceret TCO ved hjælp af intelligent rensesystem. Lang filterlevetid og optimeret fodaftryk.
- Fremtidssikret system, som er IoT forberedt - "Insight Ready".

Produkt navn	MEP SmartFilter Ex
Tryklufteforbrug	58 liter per rensespol ved 5,5 bar trykløft
Installation	Indendørs, Udendørs
Materiale	2 mm galvaniseret plade
Egnet til eksplosivt støv	True
Metode for filterrensning	Puls Jet
Applikation	Røg, Støv
Arbejdsdruk (kPa)	Vakuüm max. 6 kPa. Overtryk max. 0 Pa. (1,5 kPa for silotop version)
Volumen affaldsbeholder (l)	50 eller 100 liter affaldsspande
Filterareal (m ²)	15 - 88
Kapacitet (max luftvolumen m ³ /h)	1800 - 10500
Driftstemperatur	-20°C til +70°C
Type af filter	Kassettefilter
Filtermateriale	













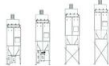

Røg Støv

MEP SmartFilter Ex

Billede	Beskrivelse	Antal filter	Model
	MEP-4-4-Ex Smartfilter	4	MEP-4-4-Ex
	MEP-6-4-Ex Smartfilter	6	MEP-6-4-Ex
	MEP-8-4-Ex Smartfilter	8	MEP-8-4-Ex
	MEP-2-6-Ex Smartfilter	2	MEP-2-6-Ex
	MEP-4-6-Ex Smartfilter	4	MEP-4-6-Ex
	MEP-6-6-Ex Smartfilter	6	MEP-6-6-Ex
	MEP-8-6-Ex Smartfilter	8	MEP-8-6-Ex
	MEP-2-4-Ex SmartFilter	2	MEP-2-4-Ex

MEP SmartFilter Ex

Accessories

Figure	Description	Figure	Description
	Top mounted FM-fans 50 Hz or 60 Hz up to 14000 m ³ /h		Leg height extensions from 0 mm to 2000 mm to fit larger bins/containers, rotary valves and big bags
	Combifab remote fans 50 Hz or 60 Hz		Leg width extension 300 mm to left, right or both sides to fit larger bins/containers, rotary valves and big bags
	Noise enclosure to reduce fan and motor break-out-noise of FM-fans		Suspension below rotary valve for big bag
	Dual silencer to reduce air flow, fan noise and motor break-out-noise of FM-fans (available with grid (indoor use), grid and rain cover (outdoor use) or flange for duct connection)		Isolation box for pressure tank incl. clearing valves
	Regulation (iris) damper at fan inlet for FM-fans		Access platform with ladder for maintenance
	Dust bins (50 l, 50 l with wheels and 100 l with wheels)		Lime feeder NFKG-70
	Plastic bag in the dust bin with pressure compensation set 'bin balancing'		Several sensors available for extraction, filtration and discharge process
	Rotary valves NRS3 and NRSZ3		Water separator and pressure regulator
	Dust discharge valve NFUS3		QF-duct system

Envelope material

- NF100 – Polyester needlefelt, singed, 500 g/m²
- NF130 – Polyester needlefelt, glazed, 500 g/m²
- NF141 – Polyester needlefelt, glazed, 400 g/m², antistatic
- NF142 – Polyester needlefelt, glazed, 500 g/m², antistatic
- NF143 – Polyester needlefelt, PTFE coating, 550 g/m², antistatic
- NF180 – Polyester needlefelt, glazed, 550 g/m²
- NF181 – Polyester needlefelt, PTFE coating, 550 g/m²

MCP Envelope material

MEP SmartFilter Ex

A – Height of Clean Air Chamber (mm)			
200	350	500	650
Shown in drawings	Add 150 mm in height	Add 300 mm in height	Add 450 mm in height

MEP A - height of clean air chamber

Product Marking of MEP SmartFilter Ex

  II 1D/3D/- c Ex h IIC 120°C Da/Dc/-

MEP SmartFilter Ex marking

Pred.max	KST	Zone Placement
0,3 bar	S11 (0 to 200 bar m s ⁻¹) S12 (> 200 to 300 bar m s ⁻¹) S13 (> 300 bar m s ⁻¹)*	None-zone Zone 22*

*Not available as standard, available by request

MEP SmartFilter Ex specifications

Filter area

Filter type	Quantity of envelopes	Filter area (m ²)	Max. airflow (m ³ /h)*
MEP-2-4 MEP-2-4-Ex	2	15	1800
MEP-4-4 MEP-4-4-Ex	4	29	3400
MEP-6-4 MEP-6-4-Ex	6	44	5200
MEP-8-4 MEP-8-4-Ex	8	58	7000
MEP-2-6 MEP-2-6-Ex	2	22	2600
MEP-4-6 MEP-4-6-Ex	4	44	5200
MEP-6-6 MEP-6-6-Ex	6	66	8000
MEP-8-6 MEP-8-6-Ex	8	88	10500

*Max. air flow is dependent on the dust type, etc.

MEP Filter area

MEP SmartFilter Ex

MEP-2.4 / MEP-2.4-Ex
MEP-2.6 / MEP-2.6-Ex

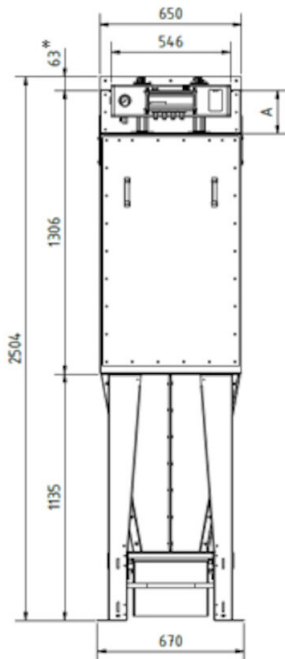

All dimensions in mm.

If 50 liter bin with wheels 90 mm must be added to the height.

* to be included only if a top mounted FM fan is used (transition for fan).

MEP SmartFilter Ex

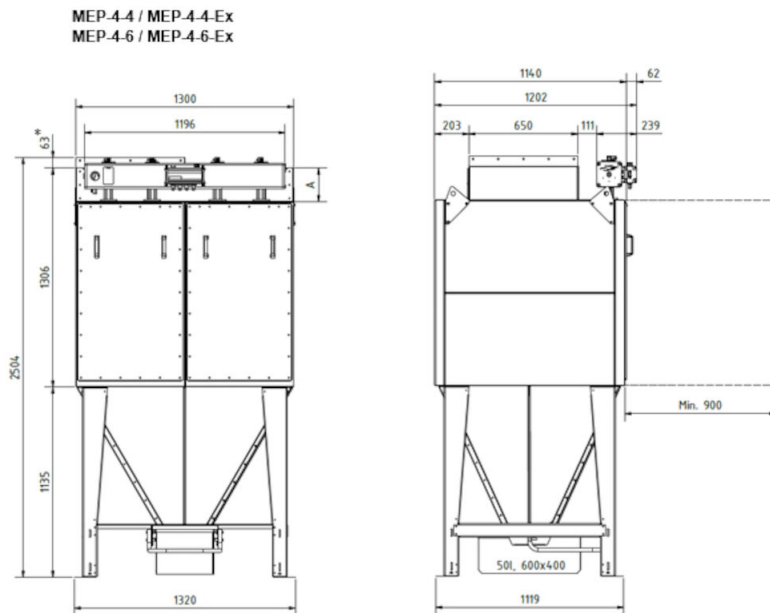

All dimensions in mm.

If 50 liter bin with wheels 90 mm must be added to the height.

* to be included only if a top mounted FM fan is used (transition for fan).

MEP SmartFilter Ex

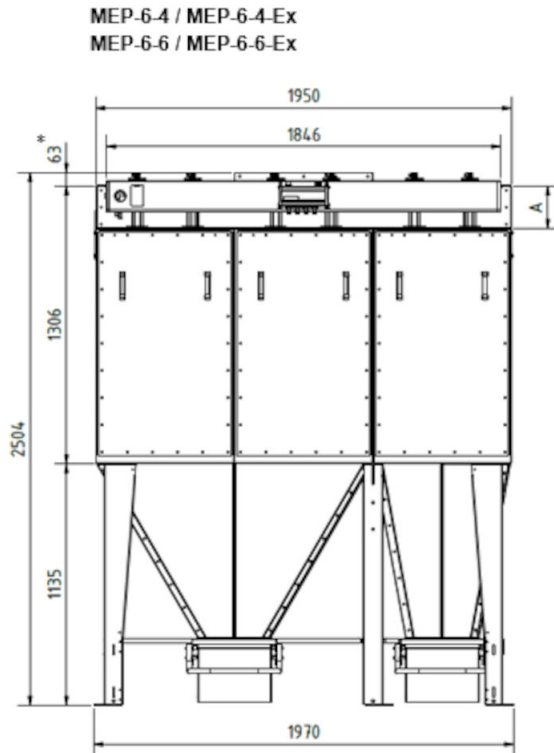

All dimensions in mm.

If 50 liter bin with wheels 90 mm must be added to the height.

* to be included only if a top mounted FM fan is used (transition for fan).

MEP SmartFilter Ex

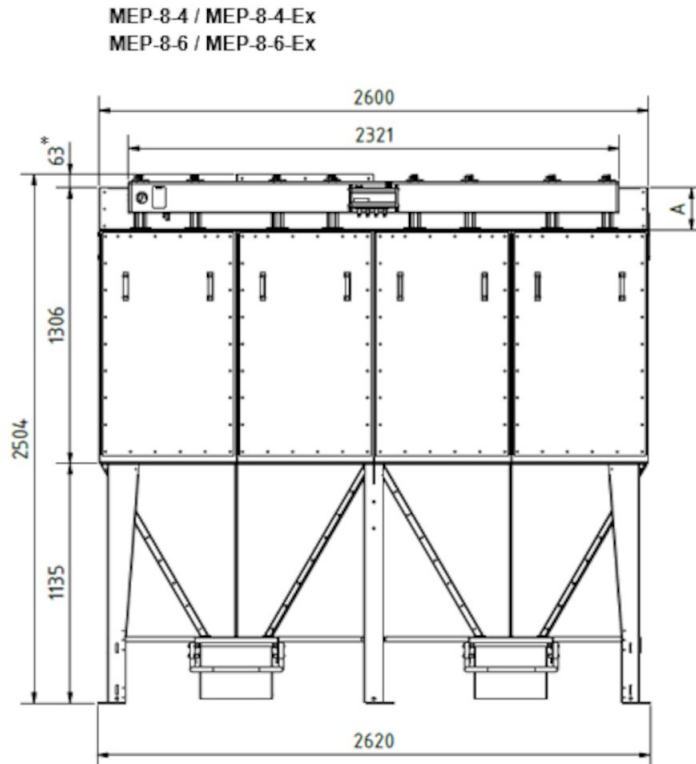

All dimensions in mm.

If 50 liter bin with wheels 90 mm must be added to the height.

* to be included only if a top mounted FM fan is used (transition for fan).