

## MEP SmartFilter Ex

MEP Smartfilter Ex er et flerbruksfilter. Det er skalerbart til å passe de fleste kundespesifike krav med luftmengder opp til 10 500 m<sup>3</sup>/t.

---

## MEP SmartFilter Ex



MEP SmartFilter EX er et flerbruks-filtreringssystem. Det kan tilpasses for å passe perfekt til kundespesifikke krav. Egnet for røyk og støv og kan brukes i flere forskjellige bruksområder som sliping, sandblåsing og generelt støv.

Den modulære utformingen gir mulighet for frittstående løsninger og multifilterløsninger for utvidede krav. MEP Smartfilter benytter gjennomprøvd høykvalitets filtermateriale som er lett å vedlikeholde. Filtermateriale for de fleste bruksområder er tilgjengelige avhengig av støvtype, støvmengde og effektivitetskrav.

Konstruert med 2 mm galvaniserte stålplater. Det er enkelt å montere, kostnadseffektivt å frakte og gir korrosjonsbeskyttelse. Designet er optimalisert for lang filterlevetid og gir lave eierkostnader.

Insight med avansert pulsrengjøringslogikk gir full systemoversikt inkludert kontroll og overvåking, samt gateway-funksjonalitet for skykommunikasjon.

MEP SmartFilter har et stort tilbehørsprogram inkludert; vifter, innløp, kasser osv. og patronfilterene er tilgjengelige i et bredt utvalg av materialer.

- Få kontroll over filtreringssystemet med Insight Analytics. Nedermans unike overvåkingsteknologi
- Optimalisert fotavtrykk gjennom innovativ patrondesign med høy luftstrøm
- Redusert livstidskostnad gjennom intelligent rengjøringsystem, lang levetid for filterkassetter og optimalisert fotavtrykk
- Fremtidsrettet system som er IoT forberedt - Insight Ready









Produktnavn	MEP SmartFilter Ex
Trykkluftforbruk	58 liter per rengjøringspuls ved 5,5 bar trykkluft
Installasjon	Innendørs, Utendørs
Materiale	2 mm galvanisert stål
Egnet for brennbart støv	True
Rengjøringsmetode, filter	Trykkluftrensing
Bruksområde	Røyk, Støv
Arbeidstrykk (kPa)	Vacuum max. 6 kPa. Overpressure max. 0 Pa. (1,5 kPa for silotop solution)
Volum, støvbeholder (L)	50 eller 100 liters beholder
Filterområdet (m <sup>2</sup> )	15 - 88
Kapasitet (maks. luftstrøm m <sup>3</sup> /t)	1800 - 10500
Driftstemperatur	-20°C - +70°C.
Filtertype	Posefilter
Filtermateriale	



# MEP SmartFilter Ex















Reyk Stav

## MEP SmartFilter Ex

Bilde	Navn på datablad	Antall filterelementer	Model
	MEP-4-4-Ex Smartfilter	4	MEP-4-4-Ex
	MEP-6-4-Ex Smartfilter	6	MEP-6-4-Ex
	MEP-8-4-Ex Smartfilter	8	MEP-8-4-Ex
	MEP-2-6-Ex Smartfilter	2	MEP-2-6-Ex
	MEP-4-6-Ex Smartfilter	4	MEP-4-6-Ex
	MEP-6-6-Ex Smartfilter	6	MEP-6-6-Ex
	MEP-8-6-Ex Smartfilter	8	MEP-8-6-Ex
	MEP-2-4-Ex SmartFilter	2	MEP-2-4-Ex

## MEP SmartFilter Ex

### Accessories

Figure	Description	Figure	Description
	Top mounted FM-fans 50 Hz or 60 Hz up to 14000 m <sup>3</sup> /h		Leg height extensions from 0 mm to 2000 mm to fit larger bins/containers, rotary valves and big bags
	Combifab remote fans 50 Hz or 60 Hz		Leg width extension 300 mm to left, right or both sides to fit larger bins/containers, rotary valves and big bags
	Noise enclosure to reduce fan and motor break-out-noise of FM-fans		Suspension below rotary valve for big bag
	Dual silencer to reduce air flow, fan noise and motor break-out-noise of FM-fans (available with grid (indoor use), grid and rain cover (outdoor use) or flange for duct connection)		Isolation box for pressure tank incl. clearing valves
	Regulation (iris) damper at fan inlet for FM-fans		Access platform with ladder for maintenance
	Dust bins (50 l, 50 l with wheels and 100 l with wheels)		Lime feeder NFKG-70
	Plastic bag in the dust bin with pressure compensation set 'bin balancing'		Several sensors available for extraction, filtration and discharge process
	Rotary valves NRS3 and NRSZ3		Water separator and pressure regulator
	Dust discharge valve NFUS3		QF-duct system

### Envelope material

- NF100 – Polyester needlefelt, singed, 500 g/m<sup>2</sup>
- NF130 – Polyester needlefelt, glazed, 500 g/m<sup>2</sup>
- NF141 – Polyester needlefelt, glazed, 400 g/m<sup>2</sup>, antistatic
- NF142 – Polyester needlefelt, glazed, 500 g/m<sup>2</sup>, antistatic
- NF143 – Polyester needlefelt, PTFE coating, 550 g/m<sup>2</sup>, antistatic
- NF180 – Polyester needlefelt, glazed, 550 g/m<sup>2</sup>
- NF181 – Polyester needlefelt, PTFE coating, 550 g/m<sup>2</sup>

MCP Envelope material

## MEP SmartFilter Ex

A – Height of Clean Air Chamber (mm)			
200	350	500	650
Shown in drawings	Add 150 mm in height	Add 300 mm in height	Add 450 mm in height

MEP A - height of clean air chamber

### Product Marking of MEP SmartFilter Ex

CE  II 1D/3D/- c Ex h IIIC 120°C Da/Dc/-

MEP SmartFilter Ex marking

Pred.max	KST	Zone Placement
0,3 bar	S11 (0 to 200 bar m s <sup>-1</sup> ) S12 (> 200 to 300 bar m s <sup>-1</sup> ) S13 (> 300 bar m s <sup>-1</sup> )*	None-zone Zone 22*

\*Not available as standard, available by request

MEP SmartFilter Ex specifications

#### Filter area

Filter type	Quantity of envelopes	Filter area (m <sup>2</sup> )	Max. airflow (m <sup>3</sup> /h)*
MEP-2-4 MEP-2-4-Ex	2	15	1800
MEP-4-4 MEP-4-4-Ex	4	29	3400
MEP-6-4 MEP-6-4-Ex	6	44	5200
MEP-8-4 MEP-8-4-Ex	8	58	7000
MEP-2-6 MEP-2-6-Ex	2	22	2600
MEP-4-6 MEP-4-6-Ex	4	44	5200
MEP-6-6 MEP-6-6-Ex	6	66	8000
MEP-8-6 MEP-8-6-Ex	8	88	10500

\*Max. air flow is dependent on the dust type, etc.

MEP Filter area

## MEP SmartFilter Ex

MEP-2.4 / MEP-2.4-Ex  
MEP-2.6 / MEP-2.6-Ex

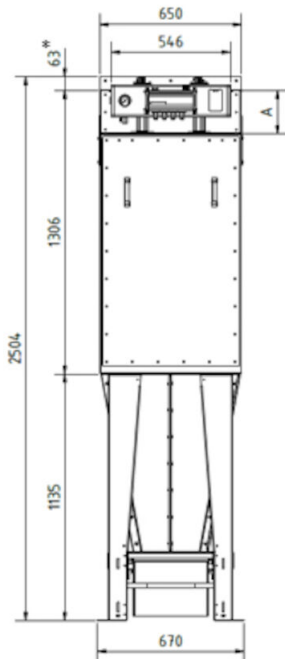

All dimensions in mm.

If 50 liter bin with wheels 90 mm must be added to the height.

\* to be included only if a top mounted FM fan is used (transition for fan).

## MEP SmartFilter Ex

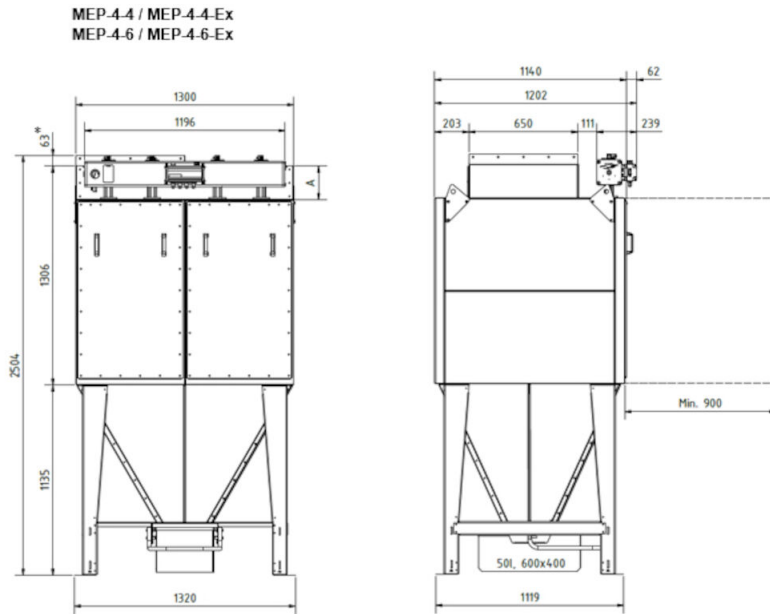

All dimensions in mm.

If 50 liter bin with wheels 90 mm must be added to the height.

\* to be included only if a top mounted FM fan is used (transition for fan).



## MEP SmartFilter Ex

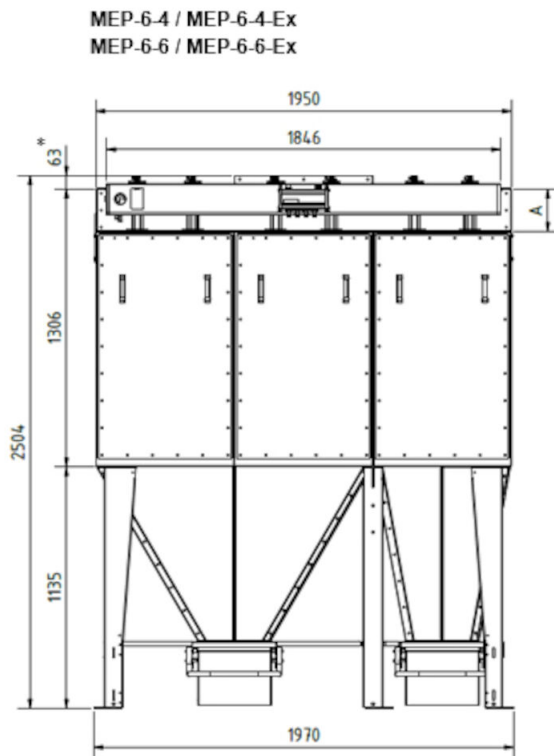

All dimensions in mm.

If 50 liter bin with wheels 90 mm must be added to the height.

\* to be included only if a top mounted FM fan is used (transition for fan).

## MEP SmartFilter Ex

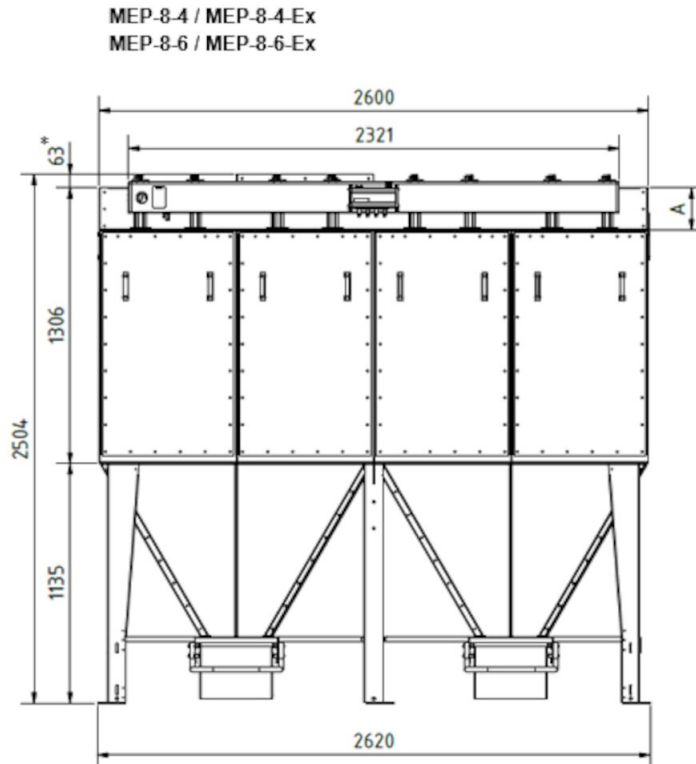

All dimensions in mm.

If 50 liter bin with wheels 90 mm must be added to the height.

\* to be included only if a top mounted FM fan is used (transition for fan).