

MEP SmartFilter Ex

MEP SmartFilter Ex is a multi-purpose filtration system. It is customizable to perfectly fit customer specific demands with airflow up to 10 500 m³/h.

MEP SmartFilter Ex



O MEP SmartFilter EX é um sistema de filtragem multifuncional. É personalizável para atender perfeitamente às exigências específicas de cada cliente. Adequado para diferentes tipos de poeira, pode ser usado em várias aplicações diferentes como polimentos, decapagem e poeira de um modo geral.

O design modular permite tanto soluções independentes como agrupamentos de vários filtros para maiores capacidades. O coletor de poeiras MEP utiliza o nosso bem sucedido filtro de tecido em bolsas, facilmente substituíveis pelas portas de dobradiças frontais. As bolsas estão disponíveis em vários tipos de materiais dependendo do tipo de poeira, carga e requisitos de eficiência. Construído com painéis de aço galvanizado de 2 mm, é fácil de instalar, transportar e fornece proteção contra corrosão. O design é otimizado para uma longa vida útil dos elementos filtrantes, proporcionando baixo custo de manutenção.

O controle pronto para Insight, com lógica avançada para comando dos pulsos de limpeza, fornece operação completa do sistema, incluindo controle e monitorização, além da funcionalidade de um gateway para comunicação via nuvem.

Totalmente compatível com as directivas globais ATEX, especialmente importantes para lidar com poeiras combustíveis. O MEP SmartFilter possui um vasto programa de acessórios, incluindo ventiladores, entradas, descargas etc. e as bolsa estão disponíveis numa ampla variedade de meios filtrantes.

- Obtenha controle total sobre o desempenho da filtragem com o Insight Analytics. A tecnologia de monitorização exclusiva da Nederman
- Espaço de implementação otimizado graças ao desenho inovador das bolsas de filtragem
- Custos de exploração reduzidos devido ao sistema de limpeza inteligente, longa vida útil dos elementos filtrantes e espaço de implementação otimizado.
- Sistema à prova de obsolescência preparado para IoT e pronto para Insight

Produto	MEP SmartFilter Ex
Consumo de ar comprimido	58 litros por pulso de limpeza a 5,5 bar de ar comprimido
Instalação	Interior, Exterior
Material	Chapa galvanizada de 2 mm de espessura
Adequado para poeiras combustíveis	True
Método de limpeza do filtro	Pulso de ar
Aplicações	Fumos, Poeira
Pressão de serviço (kPa)	Vácuo máx. 6 kPa. (1,5 kPa para solução com silo superior)
Volume do balde (l)	Balde poeiras com 50 ou 100 litros
Área Filtrante (m ²)	15 - 88

MEP SmartFilter Ex

Capacidade (máx. caudal m ³ /h)	1800 - 10500
Operating Temperature	-20°C a +70°C
Tipo de filtro	Cartucho
Material Filtrante	











Fumos



Poeira











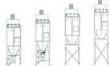





MEP SmartFilter Ex

Imagem	Descrição	Número de elementos filtrantes	Modelo
	MEP-4-4-Ex Smartfilter	4	MEP-4-4-Ex
	MEP-6-4-Ex Smartfilter	6	MEP-6-4-Ex
	MEP-8-4-Ex Smartfilter	8	MEP-8-4-Ex
	MEP-2-6-Ex Smartfilter	2	MEP-2-6-Ex
	MEP-4-6-Ex Smartfilter	4	MEP-4-6-Ex
	MEP-6-6-Ex Smartfilter	6	MEP-6-6-Ex
	MEP-8-6-Ex Smartfilter	8	MEP-8-6-Ex
	MEP-2-4-Ex SmartFilter	2	MEP-2-4-Ex

MEP SmartFilter Ex

Accessories

Figure	Description	Figure	Description
	Top mounted FM-fans 50 Hz or 60 Hz up to 14000 m ³ /h		Leg height extensions from 0 mm to 2000 mm to fit larger bins/containers, rotary valves and big bags
	Combifab remote fans 50 Hz or 60 Hz		Leg width extension 300 mm to left, right or both sides to fit larger bins/containers, rotary valves and big bags
	Noise enclosure to reduce fan and motor break-out-noise of FM-fans		Suspension below rotary valve for big bag
	Dual silencer to reduce air flow, fan noise and motor break-out-noise of FM-fans (available with grid (indoor use), grid and rain cover (outdoor use) or flange for duct connection)		Isolation box for pressure tank incl. clearing valves
	Regulation (iris) damper at fan inlet for FM-fans		Access platform with ladder for maintenance
	Dust bins (50 l, 50 l with wheels and 100 l with wheels)		Lime feeder NFKG-70
	Plastic bag in the dust bin with pressure compensation set 'bin balancing'		Several sensors available for extraction, filtration and discharge process
	Rotary valves NRS3 and NRSZ3		Water separator and pressure regulator
	Dust discharge valve NFUS3		QF-duct system

Envelope material

- NF100 – Polyester needlefelt, singed, 500 g/m²
- NF130 – Polyester needlefelt, glazed, 500 g/m²
- NF141 – Polyester needlefelt, glazed, 400 g/m², antistatic
- NF142 – Polyester needlefelt, glazed, 500 g/m², antistatic
- NF143 – Polyester needlefelt, PTFE coating, 550 g/m², antistatic
- NF180 – Polyester needlefelt, glazed, 550 g/m²
- NF181 – Polyester needlefelt, PTFE coating, 550 g/m²

MCP Envelope material

MEP SmartFilter Ex

A – Height of Clean Air Chamber (mm)			
200	350	500	650
Shown in drawings	Add 150 mm in height	Add 300 mm in height	Add 450 mm in height

MEP A - height of clean air chamber

Product Marking of MEP SmartFilter Ex

  II 1D/3D/- c Ex h IIIC 120°C Da/Dc/-

MEP SmartFilter Ex marking

Pred.max	KST	Zone Placement
0,3 bar	S11 (0 to 200 bar m s ⁻¹) S12 (> 200 to 300 bar m s ⁻¹) S13 (> 300 bar m s ⁻¹)*	None-zone Zone 22*

*Not available as standard, available by request

MEP SmartFilter Ex specifications

Filter area

Filter type	Quantity of envelopes	Filter area (m ²)	Max. airflow (m ³ /h)*
MEP-2-4 MEP-2-4-Ex	2	15	1800
MEP-4-4 MEP-4-4-Ex	4	29	3400
MEP-6-4 MEP-6-4-Ex	6	44	5200
MEP-8-4 MEP-8-4-Ex	8	58	7000
MEP-2-6 MEP-2-6-Ex	2	22	2600
MEP-4-6 MEP-4-6-Ex	4	44	5200
MEP-6-6 MEP-6-6-Ex	6	66	8000
MEP-8-6 MEP-8-6-Ex	8	88	10500

*Max. air flow is dependent on the dust type, etc.

MEP Filter area

MEP SmartFilter Ex

MEP-2.4 / MEP-2.4-Ex
MEP-2.6 / MEP-2.6-Ex

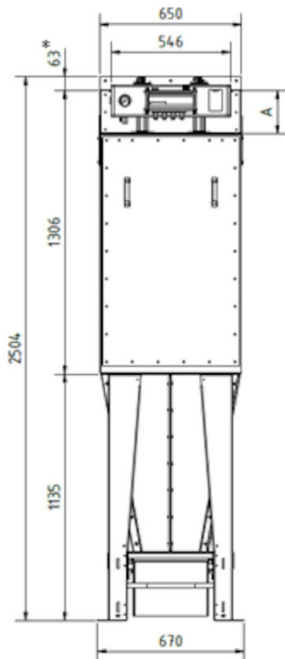

All dimensions in mm.

If 50 liter bin with wheels 90 mm must be added to the height.

* to be included only if a top mounted FM fan is used (transition for fan).

MEP SmartFilter Ex

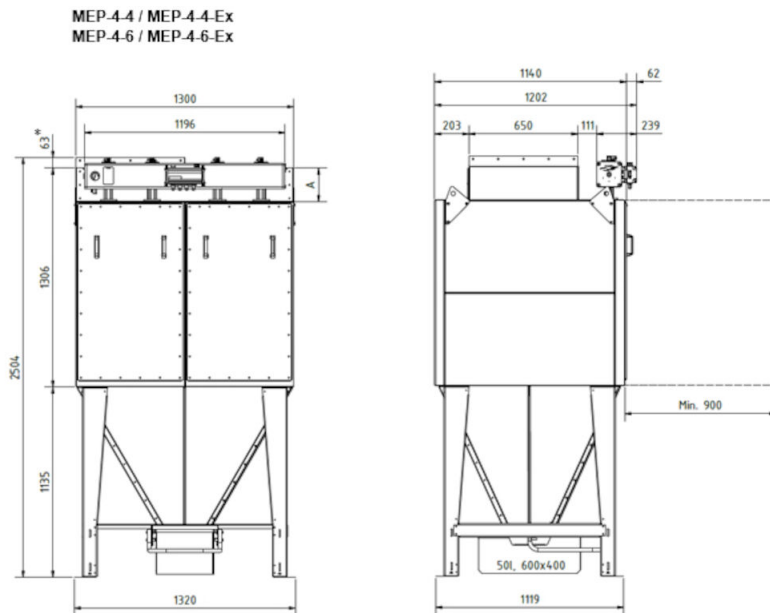

All dimensions in mm.

If 50 liter bin with wheels 90 mm must be added to the height.

* to be included only if a top mounted FM fan is used (transition for fan).

MEP SmartFilter Ex

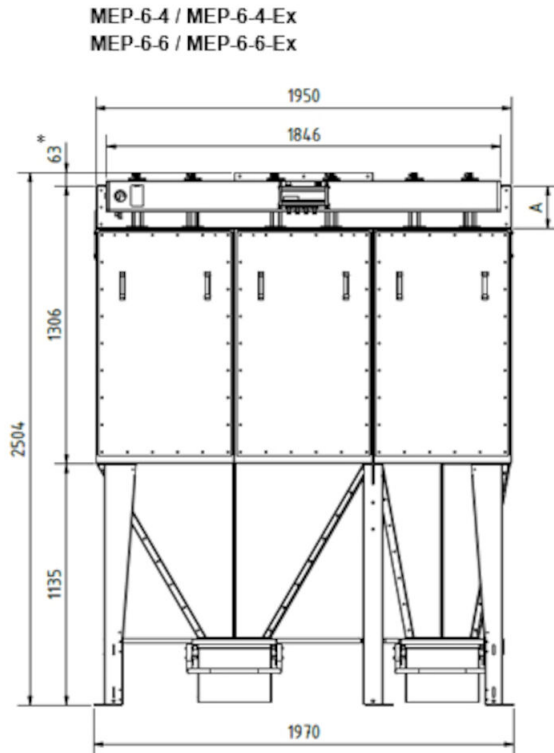

All dimensions in mm.

If 50 liter bin with wheels 90 mm must be added to the height.

* to be included only if a top mounted FM fan is used (transition for fan).

MEP SmartFilter Ex

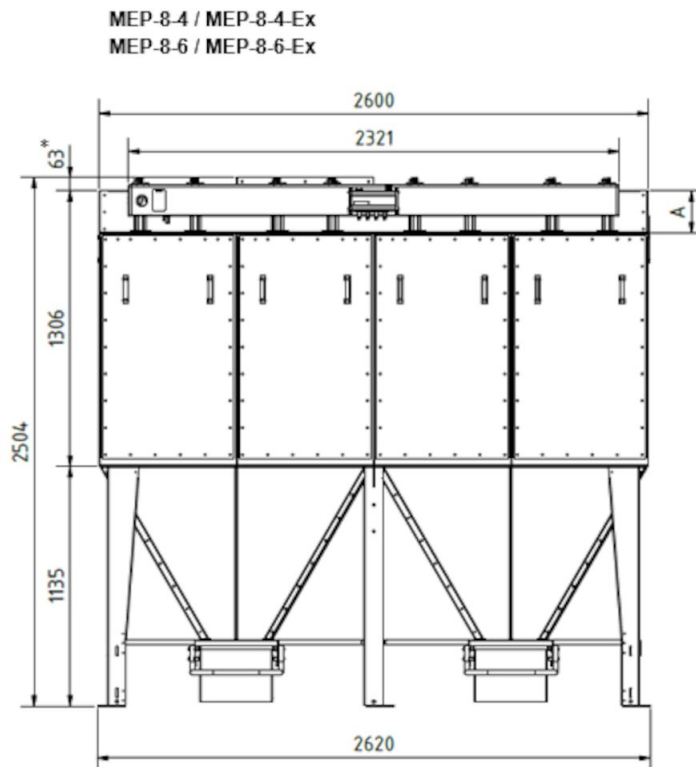

All dimensions in mm.

If 50 liter bin with wheels 90 mm must be added to the height.

* to be included only if a top mounted FM fan is used (transition for fan).