

## KSA 70 Pre-separator

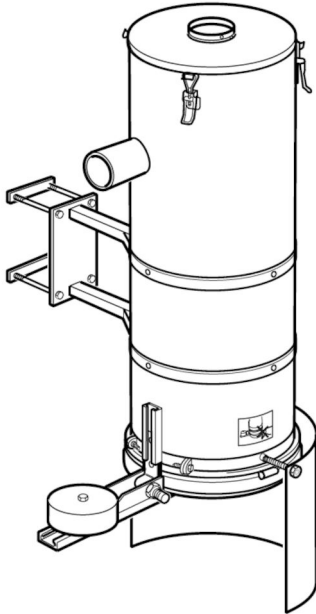

Pre-separation of metal chips and cutting fluids or similar materials near the work station to prevent wear on the pipe system. The KSA 70 has a cyclone inlet with an insert for the highest separation efficiency and wear protection. The outlet has a mechanical protection for over-filling, preventing material from being sucked into the pipework in large quantities. The balanced bottom lid opens downwards and is kept shut by the vacuum during normal operation. The installation normally requires a vacuum valve at the top of the separator, allowing emptying when the work station is not in use.

- Hassle free functionality
- None or very simple control equipment needed
- Easy to install
- Flexible mounting bracket
- Big bottom valve

|                                 |                        |
|---------------------------------|------------------------|
| Product name                    | KSA 70 Pre-separator   |
| Installation                    | Indoor                 |
| Application                     | Granulate, Grit, Swarf |
| Dustbin volume (l)              | 70                     |
| Max Airflow (m <sup>3</sup> /h) | 600                    |
| Weight (kg)                     | 50                     |



# KSA 70 Pre-separator

| Description                | Model    |
|----------------------------|----------|
| KSA 70 Preseparator Ø100mm | 40110180 |

## KSA 70 Pre-separator

| Accessory   |                        | Part No  |
|---|------------------------|----------|
|   | Column 3000 for KSA 70 | 40170460 |
|  | Splashguard KSA 70 kit | 40110190 |

## KSA 70 Pre-separator

