

# FilterBox Wall

Manually or Automatically cleaned for dust & fume applications.

---

## FilterBox Wall



FilterBox WALL can come with or without a fan attached. The models without a fan are suitable for installations with an external fan and fan contactor, and can be used with multiple FilterBox units. The unit is delivered with a wall bracket for easy installation.

FilterBox WALL M delivered with a manually cleaned polyester filter and an alarm that indicates when the air flow is too low.

FilterBox WALL A delivered with a automatically cleaned polyester filter. There is an advanced filter control system indicating the pressure drop with a series of LED's as well as on the LCD display. When the air flow is too low an auidial alarm precedes the automatic, motorized cleaning sequence.

Both WALL M and WALL A are cleaned mechanically for dust applications. For welding fumes a combination of mechanical and compressed air cleaning is used.

FilterBox WALL A+ is delivered with an extra-large, automatically cleaned nanofiber filter, ideal for frequent welding. The nanofiber media technology utilized in the WALL A+ offers significant performance advantages like higher efficiency and surface loading properties which results in more effective filter cleaning and longer cleaning intervals. Advantages that will impose benefits in terms of filter life, productivity and lower cost of ownership. There is an advanced filter control system indicating the pressure drop with a series of LED's as well as on the LCD display. An auidial alarm precedes the automatic, motorized compressed air cleaning sequence.

An integrated silencer reduces noise from the fan and outlet air. Additional protection from harmful particles is provided if a HEPA filter is installed (optional).

Note! FilterBox is not for use in environments where combustible dust or gases are present, and it is not for use in filtering combustible dust or gases.

- Several filter alternatives with Manual or Automatically operated filter cleaning for long filter life.
- On WALL A+ there is a LCD panel with operating status and menu system for parameter setup and settings.
- Automatic damper preventing dust from leaking out while cleaning.
- Dust free filter replacement and emptying of dust bin.
- Approved for welding fumes category W3 according to EN 15012-1, third party tested.

Product name	FilterBox Wall
Noise level (dB(A))	60 (without fan)

# FilterBox Wall

	66 (N24 fan) 74 (N27 fan)
Protection class	IP 54
Filter efficiency (%)	99
Compressed air requirement	DIN ISO 8573-1, class 5/5/4 (7 bar)
Installation	Indoor
Material	Casing in rotomoulded plastic
Dustbin volume (l)	15
Extraction arm diameter (mm)	160
Airflow (m <sup>3</sup> /h)	1300
Filter Area (m <sup>2</sup> )	13
Arm length (m)	Without
Filter type	Cartridge
Number of filter elements	1
Electric plug	Without
Max airflow (m <sup>3</sup> /h)	1300



# FilterBox Wall

Image	Description	Power Voltage (V)	Frequency (Hz)	No of phases	Filter material	Weight (kg)	Filter cleaning method	Power (kW)	Filter Area (m <sup>2</sup> )	Model
	FilterBox Wall, manual filter cleaning	400	50	3	Polyester PW13	54	Mechanical ,Compressed air	0,9		12650263*
	FilterBox Wall, automatic filter cleaning	230	50	1	Polyester PW13	54	Mechanical ,Compressed air			12682063**
	FilterBox Wall, automatic filter cleaning	110	50	1	Polyester PW13	54	Mechanical ,Compressed air			12682163**
	FilterBox Wall, automatic filter cleaning	110	60	1	Polyester PW13	54	Mechanical ,Compressed air	1,5		12684063**
	FilterBox Wall, manual filter cleaning	200	60	3	Polyester PW13	54	Mechanical ,Compressed air	0,9		12651063*
	FilterBox Wall, manual filter cleaning	200	60	3	Polyester PW13	54	Mechanical ,Compressed air	2,2		12651163*
	FilterBox Wall, manual filter cleaning	230	50	3	Polyester PW13	54	Mechanical ,Compressed air	0,9		12650063*
	FilterBox Wall, manual filter cleaning	230	50	3	Polyester PW13	54	Mechanical ,Compressed air	2,2		12650163*
	FilterBox Wall, manual filter cleaning	400	50	3	Polyester PW13	54	Mechanical ,Compressed air	2,2		12650363*
	FilterBox Wall, manual filter cleaning	460	60	3	Polyester PW13	54	Mechanical ,Compressed air	0,9		12650763*
	FilterBox Wall, automatic filter cleaning with N29 fan	400	50	3	Polyester PW13	90	Mechanical ,Compressed air	2,2		12684863
	FilterBox Wall, manual filter cleaning with N24 fan	400	50	3	Polyester PW13	90	Mechanical ,Compressed air	0,9		12684563***
	FilterBox Wall, manual filter cleaning with N29 fan	400	50	3	Polyester PW13	90	Mechanical ,Compressed air	2,2		12684763***
	FilterBox Wall, automatic filter cleaning with N24 fan	400	50	3	Polyester PW13	90	Mechanical ,Compressed air	0,9		12684663
	FilterBox Wall, automatic filter cleaning with N27 fan	115	60	1	Polyester PW13	90	Mechanical ,Compressed air	1,5		12688463

# FilterBox Wall

Image	Description	Power Voltage (V)	Frequency (Hz)	No of phases	Filter material	Weight (kg)	Filter cleaning method	Power (kW)	Filter Area (m <sup>2</sup> )	Model
	FilterBox Wall, automatic filter cleaning with N27 fan	230	60	3	Polyester PW13	90	Mechanical ,Compressed air	2		12688563
	FilterBox Wall, automatic filter cleaning with N27 fan	460	60	3	Polyester PW13	90	Mechanical ,Compressed air			12688663
	FilterBox Wall, automatic filter cleaning with N29 fan	230	60	3	Polyester PW13	90	Mechanical ,Compressed air	3		12688863
	FilterBox Wall, automatic filter cleaning with N29 fan	460	60	3	Polyester PW13	90	Mechanical ,Compressed air	3		12688963
	FilterBox Wall A+, Automatic Cleaning	230	50	1	Nanofiber	54	Compressed air		17	12697563****
	FilterBox Wall A+, Automatic cleaning	110	50	1	Nanofiber	54	Compressed air		17	12697663****
	FilterBox Wall A+, Automatic cleaning	230	60	1	Nanofiber	54	Compressed air	1,5	17	12697763****
	FilterBox Wall A+, Automatic cleaning	110	60	1	Nanofiber	54	Compressed air	1,5	17	12697863****
	FilterBox Wall A+, Automatic cleaning	400	50	3	Nanofiber	90	Compressed air	2,2	17	12698063***
	FilterBox Wall A+, Automatic cleaning	115	60	1	Nanofiber	90	Compressed air	1,5	17	12698163****
	FilterBox Wall A+, Automatic cleaning	230	60	3	Nanofiber	90	Compressed air	2	17	12698263****
	FilterBox Wall A+, Automatic cleaning	460	60	3	Nanofiber	90	Compressed air		17	12698363****
	FilterBox Wall A+, Automatic cleaning	230	60	3	Nanofiber	90	Compressed air	3	17	12698563****
	FilterBox Wall A+, Automatic cleaning	460	60	3	Nanofiber	90	Compressed air	3	17	12698663***
	FilterBox Wall A+, Automatic cleaning	575	60	3	Nanofiber	90	Compressed air	3	17	12698763****

## FilterBox Wall

Image	Description	Power Voltage (V)	Frequency (Hz)	No of phases	Filter material	Weight (kg)	Filter cleaning method	Power (kW)	Filter Area (m <sup>2</sup> )	Model
	FilterBox Wall A+, Automatic cleaning	400	50	3	Nanofiber	90	Compressed air	0,9	17	12697963****

\*Without Fan. Not possible to use with sensor clamp, HEPA filter or Special Top Outlet square to round Ø 200.









\*\*Without Fan. Not possible to use with HEPA filter or Special Top Outlet square to round Ø 200.

\*\*\*Not possible to use with sensor clamp.

\*\*\*\*Without Fan. Not possible to use with HEPA filter or Special Top Outlet square to round Ø 200. Filter class F9 (EN779), MERV 15 (ASHRAE 52.2)

\*\*\*\*\*Filter class F9 (EN779), MERV 15 (ASHRAE 52.2)

## FilterBox Wall

Accessory		Part No
	Outlet with duct connection D=200mm	12376749
	Sensor Clamp	14372199
	Filter-PW-FB-13	12332672
	Filter-PW HE-FB-15	12371106
	Filter PWA-FB-15	12371412
	HEPA filter H14 10m2 Filterbox	12376756
	HEPA filter H13 10m2 Filterbox	12376615
	Bags for Filterbox dust bin, 10pcs	12376618
	Twin Module blue	12376801
	Filter NANO-FB-17	12377251
	Filter PTFE-FB-13	12377252

## FilterBox Wall

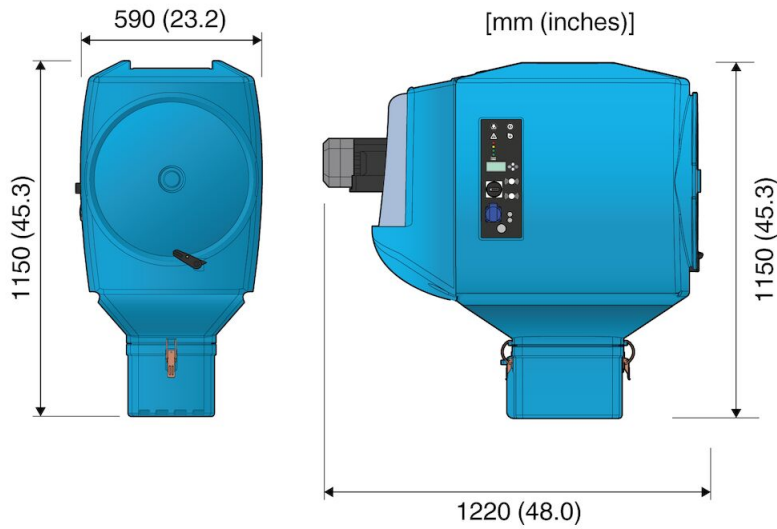

FilterBox Wall with N24 fan included

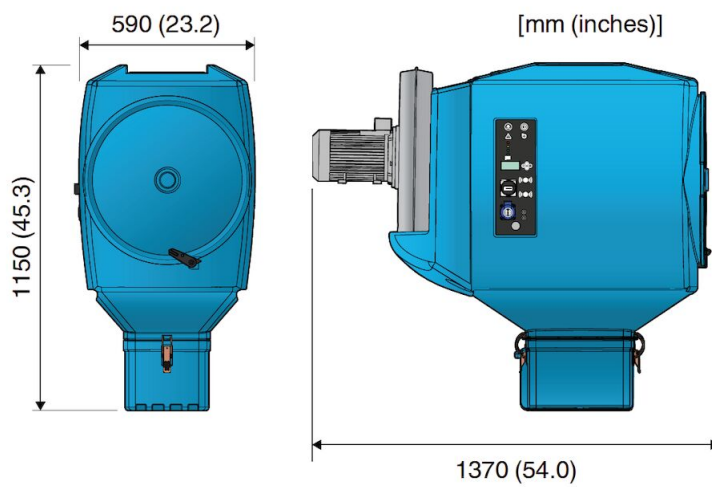

FilterBox Wall with N29 fan included



## FilterBox Wall

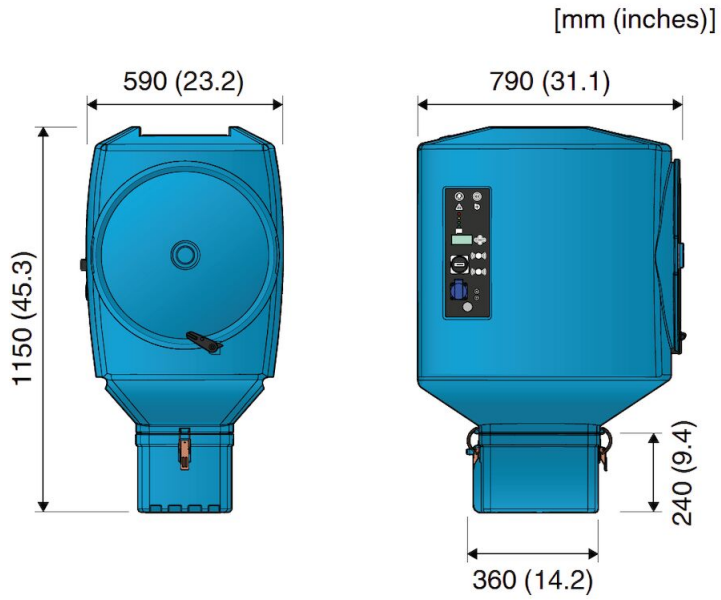

FilterBox wall without fan