

Electric powered series

Bb216 - NEL3R, S50, 2.5/2.4kW 230V 50/60Hz

42421629



Original instruction manual

EN INSTRUCTION MANUAL

Translation of original instruction manual

CS NÁVOD K OBSLUZE

DA BETJENINGSVEJLEDNING

DE BEDIENUNGSANLEITUNG

ES MANUAL DE INSTRUCCIONES

FI KÄYTTÖOHJEET

FR MANUEL D'INSTRUCTION

HU FELHASZNÁLÓI KÉZIKÖNYV

IT MANUALE D'ISTRUZIONE

NL HANDLEIDING

NO BRUKSANVISNING

PL INSTRUKCJA UŻYTKOWANIA

RO MANUAL DE UTILIZARE

RU РУКОВОДСТВО ПО ЭКСПЛУАТАЦИИ

SV ANVÄNDARMANUAL

Declaration of conformity

EN English

Declaration of conformity

We, AB Ph. Nederman & Co., declare under our sole responsibility that the Nederman product:

Bb units: Bb104, Bb115, Bb116, Bb181, Bb206, Bb216, Bb218, Bb221, Bb306, Bb420, Bb426 and Bb515 with accessories to which this declaration relates, are in conformity with the following:

Directives

2006/42/EC, 2004/108/EC, 2006/95/EC.

Standards

EN ISO 12100, EN 60335-2-69, EN60335-1, EN55014-1 and 2, EN61000-3-2 and-3-3.

Warning

110V units can affect other electrical equipment.

DA Dansk

Overensstemmelseserklæring

Vi, AB Ph. Nederman & Co. erklærer som eneansvarlige, at produkterne fra Nederman:

Bb-enhederne: Bb104, Bb115, Bb116, Bb181, Bb206, Bb216, Bb218, Bb221, Bb306, Bb420, Bb426 og Bb515 og tilbehør dertil, som denne erklæring vedrører, er i overensstemmelse med bestemmelserne i følgende direktiver og standarder:

Direktiver

2006/42/EC, 2004/108/EC, 2006/95/EC.

Standarder

EN ISO 12100, EN 60335-2-69, EN60335-1, EN55014-1 og 2, EN61000-3-2 og-3-3.

Advarsel

110V-enheder kan påvirke andre elektriske apparater.

ES Español

Declaración de Conformidad

Nosotros, AB Ph. Nederman & Co., declaramos bajo nuestra única responsabilidad que el producto Nederman:

Unidades Bb: Bb104, Bb115, Bb116, Bb181, Bb206, Bb216, Bb218, Bb221, Bb306, Bb420, Bb426 y Bb515 con accesorios, a los que se refiere esta declaración, cumplen con las disposiciones de las siguientes:

Directivas

2006/42/EC, 2004/108/EC, 2006/95/EC.

Normas

EN ISO 12100, EN 60335-2-69, EN60335-1, EN55014-1 y 2, EN61000-3-2 y-3-3.

Advertencia

110 unidades puede afectar a otros equipos eléctricos.

SV Svenska

Försäkran om överensstämmelse

Vi, AB Ph. Nederman & Co. försäkrar under eget ansvar att Nederman-produkten:

Bb-enheter: Bb104, Bb115, Bb116, Bb181, Bb206, Bb216, Bb218, Bb221, Bb306, Bb420, Bb426 och Bb515 med tillbehör som omfattas av denna försäkran är i överensstämmelse med följande:

Direktiv

2006/42/EC, 2004/108/EC, 2006/95/EC.

Standarder

EN ISO 12100, EN 60335-2-69, EN60335-1, EN55014-1 och 2, EN61000-3-2 och-3-3.

Varning

Enheter med 110V kan påverka annan elektrisk utrustning.

CS Český

Prohlášení o shodě

My, společnost AB Ph. Společnost Nederman & Co. prohlašuje na svou zodpovědnost, že výrobek Nederman:

jednotky Bb: Bb104, Bb115, Bb116, Bb181, Bb206, Bb216, Bb218, Bb221, Bb306, Bb420, Bb426 a Bb515 s příslušenstvími, kterých se toto prohlášení týká, jsou v souladu s těmito předpisy:

Směrnice

2006/42/EC, 2004/108/EC, 2006/95/EC.

Normy

EN ISO 12100, EN 60335-2-69, EN60335-1, EN55014-1 a 2, EN61000-3-2 a-3-3.

Upozornění

110 jednotek může ovlivnit ostatní elektrická zařízení.

DE Deutsch

Konformitätserklärung

Wir, AB Ph. Nederman & Co., erklären in alleiniger Verantwortung, dass das Nederman Produkt:

Bb-Einheiten: Bb104, Bb115, Bb116, Bb181, Bb206, Bb216, Bb218, Bb221, Bb306, Bb420, Bb426 und Bb515 mit dem Zubehör, auf das sich diese Erklärung bezieht, den folgenden Normen entspricht:

Richtlinien

2006/42/EC, 2004/108/EC, 2006/95/EC.

Standards

EN ISO 12100, EN 60335-2-69, EN60335-1, EN55014-1 und 2, EN61000-3-2 und-3-3.

Warnung

110V-Einheiten können auf andere elektrische Geräte.

FI Suomi

Vaatimustenmukaisuusvakuutus

Me, AB Ph. Nederman & Co., vakuutamme yksinomaan omalla vastuullamme, että Nederman-tuote

Bb-yksiköt: Bb104, Bb115, Bb116, Bb181, Bb206, Bb216, Bb218, Bb221, Bb306, Bb420, Bb426 ja Bb515 sekä niiden lisävarusteet, joihin tämä vakuutus liittyy, täyttävät seuraavat vaatimukset:

Direktiivit

2006/42/EC, 2004/108/EC, 2006/95/EC.

Standardit

EN ISO 12100, EN 60335-2-69, EN60335-1, EN55014-1 ja 2, EN61000-3-2 ja-3-3.

Varoitus

110V yksiköt voivat vaikuttaa muita sähkölaitteita.

FR Français

Déclaration de conformité

Nous, AB Ph. Nederman & Co., déclarons sous notre seule responsabilité, que les produits Nederman : Unités Bb : Bb104, Bb115, Bb116, Bb181, Bb206, Bb216, Bb218, Bb221, Bb306, Bb420, Bb426 et Bb515 et accessoires auxquels cette déclaration s'applique, sont conformes aux directives et normes suivantes :

Directives

2006/42/EC, 2004/108/EC, 2006/95/EC.

Normes

EN ISO 12100, EN 60335-2-69, EN60335-1, EN55014-1 et 2, EN61000-3-2 et-3-3.

Avertissement

Unités de 110V peut affecter d'autres équipements électriques.

HU Magyar

Megfelelőségi Nyilatkozat

Mi, az AB Ph. Nederman & Co. nevében, felelősségünk tudatában kijelentjük hogy a(z)

Bb egységek: Bb104, Bb115, Bb116, Bb181, Bb206, Bb216, Bb218, Bb221, Bb306, Bb420, Bb426 és Bb515, valamint azon kellékek, amelyekre ez a nyilatkozat vonatkozik, megfelelnek az alábbiaknak:

Direktíváknak

2006/42/EC, 2004/108/EC, 2006/95/EC.

Szabványoknak

EN ISO 12100, EN 60335-2-69, EN60335-1, EN55014-1 és 2, EN61000-3-2 és-3-3.

Figyelem

110V egységek befolyásolhatják más elektromos berendezéseket.

NL Nederlands

Conformiteitsverklaring

Wij, AB Ph. Nederman & Co, verklaren in uitsluitende aansprakelijkheid dat het product van Nederman:

Bb-eenheden: Bb104, Bb115, Bb116, Bb181, Bb206, Bb216, Bb218, Bb221, Bb306, Bb420, Bb426 en Bb515 met toebehoren waarop deze verklaring van toepassing is, in overeenstemming zijn met de volgende:

Richtlijnen

2006/42/EC, 2004/108/EC, 2006/95/EC.

Normen

EN ISO 12100, EN 60335-2-69, EN60335-1, EN55014-1 en 2, EN61000-3-2 en -3-3.

Waarschuwing

110V-eenheden kunnen gevolgen hebben voor andere elektrische apparatuur.

PL Polski

Deklaracja zgodności

My, AB Ph. Nederman & Co., niniejszym oświadczamy na naszą własną odpowiedzialność, że produkty:

jednostki Bb: Bb104, Bb115, Bb116, Bb181, Bb206, Bb216, Bb218, Bb221, Bb306, Bb420, Bb426 i Bb515 wraz z akcesoriami, których dotyczy niniejsza deklaracja, są zgodne z następującymi:

Dyrektywy

2006/42/EC, 2004/108/EC, 2006/95/EC.

Normy

EN ISO 12100, EN 60335-2-69, EN60335-1, EN55014-1 i 2, EN61000-3-2 i -3-3.

Ostrzeżenie

110V Jednostki mogą mieć wpływ innych urządzeń elektrycznych.

RU Русский

Заявление о соответствии

Мы, AB Ph. Nederman & Co., заявляем об исключительной ответственности, что оборудование Nederman:

Устройства Bb: Bb104, Bb115, Bb116, Bb181, Bb206, Bb216, Bb218, Bb221, Bb306, Bb420, Bb426 и Bb515 с дополнительным оборудованием, к которому относится эта декларация, соответствует следующим требованиям:

Директивы

2006/42/EC, 2004/108/EC, 2006/95/EC.

Стандарты

EN ISO 12100, EN 60335-2-69, EN60335-1, EN55014-1 и 2, EN61000-3-2 и -3-3.

Предупреждение

110 единиц может повлиять на другого электрического оборудования.

IT Italiano

Dichiarazione di conformità

Noi, AB Ph. Nederman & Co., dichiariamo sotto la nostra esclusiva responsabilità che il prodotto Nederman:

Unità Bb: Bb104, Bb115, Bb116, Bb181, Bb206, Bb216, Bb218, Bb221, Bb306, Bb420, Bb426 e Bb515 e relativi accessori, oggetto di questa dichiarazione, sono conformi alle seguenti:

Direttive

2006/42/EC, 2004/108/EC, 2006/95/EC.

Norme

EN ISO 12100, EN 60335-2-69, EN60335-1, EN55014-1 ed 2, EN61000-3-2 ed-3-3.

Attenzione

Unità 110V può influire su altri apparecchi elettrici.

NO Norsk

Samsvarserklæring

Vi, AB Ph. Nederman & Co, erklærer på eget ansvar at Nedermans produkt:

Bb-enhetene: Bb104, Bb115, Bb116, Bb181, Bb206, Bb216, Bb218, Bb221, Bb306, Bb420, Bb426 og Bb515 med tilbehør som denne erklæring gjelder for, er i overensstemmelse med følgende:

Direktiver

2006/42/EC, 2004/108/EC, 2006/95/EC.

Standarder

EN ISO 12100, EN 60335-2-69, EN60335-1, EN55014-1 og 2, EN61000-3-2 og-3-3.

Advarsel

110V enheter kan påvirke annet elektrisk utstyr.

RO Română

Declarație de conformitate

Firma AB Ph. Nederman & Co. declară pe proprie răspundere că produsele Nederman:

unitățile Bb: Bb104, Bb115, Bb116, Bb181, Bb206, Bb216, Bb218, Bb221, Bb306, Bb420, Bb426 și Bb515 cu accesoriile la care se referă prezenta declarație respectă:

Directivele

2006/42/EC, 2004/108/EC, 2006/95/EC.

Standardele

EN ISO 12100, EN 60335-2-69, EN60335-1, EN55014-1 și 2, EN61000-3-2 și-3-3.

Avertizare

Unități de 110V poate afecta alte echipamente electrice.







AB Ph. Nederman & Co.
P.O. Box 602
SE-251 06 Helsingborg
Sweden









Christian Norman
Technical Manager



Warnings and prohibitions

	 Max 8 bar	 230VAC				
EN	Compressed air, max 8 bar	Alternating current	Moving pneumatic cylinder	Unstable	Noise	Crush risk
SV	Tryckluft, max 8 bar	Växelström	Rörlig luftcylinder	Instabil	Oljud	Klämrisk
FI	Paineilma, maks. 8 bar	Vaihtovirta	Liikkuva paineilmasylinteri	Epävaka	Melua	Puristumisvaara
DE	Druckluft, max. 8 Bar	Wechselstrom	Beweglicher Druckluftzylinder	Instabil	Geräusch	Klemm- gefahr
DA	Trykluft, maks. 8 bar	Vekselstrøm	Bevægelig trykluftscylinder	Ustabil	Støj	Klemfare
NO	Trykkluft, maks. 8 bar	Vekselstrøm	Bevegelig pneumatisk sylinder	Ustabil	Støy	Klemfare
NL	Perslucht, max. 8 bar	Wisselstroom	Bewegende pneumatische cilinder	Onstabiel	Geluid	Beknellingsge- vaar
HU	Sűrített levegő, max. 8 bar	Váltóáram	Mozgó pneumatikus munkahenger	Ingatag	Zaj	Becsípődés veszélye
PL	Powietrze sprężone, maks. 8 bar	Prąd zmienny	Przesuwający się siłownik pneumatyczny	Niestabilność	Hałas	Niebezpieczeń- stwo wciągnięcia
ES	Aire comprimido, máx. 8 bar	Corriente alterna	Cilindro neumático en movimiento	Inestable	Ruido	Riesgo de pel- lizcamiento
RO	Aer comprimat, maximum 8 bari	Curent alternativ	Cilindru pneumatic mobil	Instabil	Zgomot	Risc de prindere
IT	Aria compressa, max 8 bar	Corrente alternata	Cilindro pneumatico in movimento	Instabile	Rumore	Rischio di schiac- ciamento
FR	Air comprimé, max. 8 bars	Courant alternatif	Vérin pneumatique mobile	Instable	Bruit	Risque de pincement
CS	Stlačený vzduch, max. 8 barů	Střídavý proud	Pohybující se pneumatický válec	Nestabilní	Hluk	Nebezpečí přimáčknutí
RU	Сжатый воздух, макс. 8 бар	Переменный ток	Движущийся пневматический цилиндр	Неустойчивое положение	Шум	Опасность за- щемления

				 Max 8 bar		
EN	Do not use caustics	Do not use explosive materials	Do not use hazardous materials	Do not use compressed air over 8 bar	Do not use crane	Do not place unstable
SV	Använd ej frätande material	Använd ej explosiva material	Använd ej giftiga material	Använd ej tryckluft över 8 bar	Använd ej kran	Placeras ej instabilt
FI	Ei emäksisille aineille	Ei räjähtäville aineille	Ei vaarallisille aineille	Ei yli 8 baarin paineilmalle	Nosturin käyttö kielletty	Sijoitettava vakaasti paikalleen
DE	Keine ätzenden Substanzen verwenden.	Keine explosiven Materialien verwenden	Keine gefährlichen Materialien verwenden	Keinen Luftdruck über 8 Bar nutzen.	Keinen Kran verwenden.	Einheit stabil aufstellen.
DA	Der må ikke anvendes ætsende midler	Der må ikke anvendes sprængfarlige materialer	Der må ikke anvendes sundhedsfarlige materialer	Der må ikke anvendes trykluft over 8 bar	Der må ikke anvendes kran	Må ikke placeres ustabilt
NO	Forbudt å bruke etsende middel	Forbudt å bruke eksplosive materialer	Forbudt å bruke farlige materialer	Forbudt å bruke trykkluft over 8 bar	Forbudt å bruke kran	Forbudt å plassere ustabilt
NL	Geen bijtend materiaal gebruiken	Geen explosief materiaal gebruiken	Geen gevaarlijk materiaal gebruiken	Geen perslucht van meer dan 8 bar gebruiken	Geen kraan gebruiken	Niet onstabiel plaatsen
HU	Ne használjon maró anyagokat	Ne használjon robbanásveszélyes anyagokat	Ne használjon veszélyes anyagokat	Ne használjon 8 bar-nál nagyobb nyomású levegőt	Ne használjon darut	Ne helyezze ingatag felületre
PL	Nie używaj substancji żrących	Nie używaj materiałów wybuchowych	Nie używaj materiałów niebezpiecznych	Nie używaj ciśnienia sprężonego o wartości wyższej niż 8 bar	Nie używaj suwnicy	Nie ustawiaj w położeniu niestabilnym
ES	No utilizar cáusticas	No utilizar materiales explosivos	No utilizar materiales peligrosos	No utilizar aire comprimido de más de 8 bar	No utilizar grúa	No colocar en posición inestable
RO	Nu utilizați substanțe caustice	Nu utilizați materiale explozive	Nu utilizați materiale periculoase	Nu utilizați aer comprimat cu presiune de peste 8 bari	Nu utilizați macara	Nu așezați în poziție instabilă
IT	Non utilizzare materiali caustici	Non utilizzare materiali esplosivi	Non utilizzare materiali pericolosi	Pressione max dell'aria compressa: 8 bar	Non utilizzare una gru	Non collocare in luoghi instabili
FR	Ne pas utiliser de matériaux caustiques	Ne pas utiliser de matériaux explosifs	Ne pas utiliser de matériaux dangereux	Ne pas utiliser d'air comprimé supérieur à 8 bars	Ne pas utiliser de grue	Ne pas placer de manière instable
CS	Nepoužívejte žraviny	Nepoužívejte výbušné materiály	Nepoužívejte nebezpečné materiály	Nepoužívejte stlačený vzduch o tlaku nad 8 barů	Nepoužívejte jeřáb	Nepokládejte nestabilně
RU	Не используйте едкие вещества	Не используйте взрывоопасные материалы	Не используйте опасные материалы	Не используйте сжатый воздух давлением выше 8 бар	Не используйте кран	Не размещайте в неустойчивом положении



Safety

Study this manual carefully before using the vacuum cleaner for the first time.

Only authorized personnel are allowed to carry out electrical installation.

Get appropriate medical care immediately if in case of a personal injury.

Only connect a vacuum cleaner with a 1-phase motor to an earthed power socket that has the same voltage as that listed on the vacuum cleaner's nameplate.

Do not use the vacuum cleaner to collect material that is hot, explosive, highly flammable, chemically unstable, spontaneously ignitable, or which can release sparks. The vacuum cleaner must be ATEX approved for the appropriate zone if it is located near this type of material.

Always disable the control system before disconnecting power to the vacuum cleaner.

Completely disconnect the vacuum cleaner from all power sources before any type of service or transportation.

Replace all damaged components with original spare parts.

Do not remove the cover of the vacuum cleaner once it is started.

Do not put the vacuum hose inlet near a person's head.

Wear an approved breathing mask, and be careful not to spread dust when changing filters. Empty the dust into a container or plastic bag.

Do not use the vacuum cleaner if there is restricted or no airflow. The fan motor can become overheated.

Turn off the vacuum cleaner if liquid or foam escapes from it.

Store the vacuum cleaner in standing position.

Operating instructions

Generally, all the vacuum cleaners are delivered for use with dry material. For use with wet material, vacuum cleaners are delivered with a filter basket and float ball. For more information, please contact the distributor or manufacturer.

Bulk-bags

Certain Ex products should be equipped with conductive bulk-bags for collecting material. Other collection methods may be used if the system risk analysis finds them to be safe.

Vacuum cleaner use, dry material:

1. Connect power supply.
2. Turn on switch to start the vacuum cleaner.
3. When the filter is clogged, the suction power is reduced.
4. Switch off the vacuum cleaner before filter cleaning and emptying the container.
 - a. Clean the cartridge filter by tapping it slightly on the floor.
 - b. Shake or wash the filter bag.
 - c. Replace the dust bag.

NOTE! Ab/Bb 216, 221, and 426 have an outside cleaning handle. See the filter cleaning section.

Vacuum cleaner use, wet material:

1. Connect power supply.
2. Turn on switch to start the vacuum cleaner.
3. When the container is full, the suction flow is shut off by the float ball.
4. Switch off the vacuum cleaner before emptying the container.

Vacuum cleaner use, NCF filter:

1. Connect power supply.
2. Turn on switch to start the vacuum cleaner.
3. When the filter is clogged, the suction power is reduced.
4. Switch off the vacuum cleaner before emptying or cleaning the filter.
5. Connect the compressed air line to the compressed air feeding hose to start filter cleaning.
 - a. Repeated filter cleaning is done by a new connection for 15 seconds.
6. Disconnect the compressed air when done.

Vacuum cleaner use, pre-separator:

1. Connect power supply.
2. Turn on switch to start the vacuum cleaner.
3. When the filter is clogged or the pre-separator is full, the suction power is reduced.
4. Switch off the vacuum cleaner before emptying the pre-separator or cleaning the filter.
5. Clean the filter as described in *Vacuum cleaner use, NCF filter*.

Service



WARNING! Risk of personal injury.

Completely disconnect the vacuum cleaner from all power sources before any type of service.

External control, unit off:

- Control and replace cables and plugs if damaged.
- Replace leaking suction hoses and couplings

Internal control, unit off:

- Check regularly that the rubber pad on the wear plate in the silo is not damaged or frayed.

Internal control, unit on:

- Replace worn out and leaking gaskets.
- Repair or replace worn out filters to avoid wear and tear of the turbine rotor or blow through of dust.
- Replace torn or full dust bag.
- Repair or replace reusable dust bag. Clean the dust bag if it becomes dirty.

Control with top cover attached, unit on:

- Start the motors in sequence using the main switch. If the main switch does not function properly or is damaged, replace it.
- If specified vacuum is not reached, check all gaskets and connections. Execute the vacuum test with suction inlet(s) closed.
- If the noise level is higher than the maximum specified, dismantle the silencer hood and check the silencing material. Replace it if it is damaged.

Control with top cover removed, unit on:

- Start the vacuum with the top cover removed.
- Control that the motors are running clockwise as seen from above.



WARNING! Risk of Personal injury.

Do not touch the motor with any tool during this operation.

- Control the thermal function by clogging the cooling air inlets with sheets of paper. The vacuum should soon stop without getting overheated (about 75°C/167 °F).

Control with top and secondary covers removed, unit off:

- Control that all cable connections are properly secured and screws tightened.
- Control that the carbon brushes are not worn out. Replace them if necessary.
- Control wear of commutator. Replace motor if commutator is grooved.
- Turn motor. If there is resistance in the bearings or turbo fan, replace the motor.
- If any wiring in the circuit board is burned, replace the card.

Trouble Shooting

Problem	Fault	Solution
Motor will not start	Electrical supply not connected	Connect the electrical supply.
	Thermoswitch not reset or defect (T-mod)	Dismantle top cover and clean or exchange cooling air filter. Reset the thermoswitch. If the thermoswitch is defect, please contact the distributor.
	Switch supply or cable defect	Contact the distributor
	Radio interference suppression defect	Contact the distributor
None or bad suction capacity	Switch not completely turned on	Turn switch on
	One or two motors defect	Dismantle top cover, control the brushes and commutators. If the brushes are worn out, please replace. If the commutators are burnt, contact the distributor.
	Clogged suction hose or inlet	Disconnect suction hose. Turn and suck in the opposite direction. If still clogged, open it with a rod.
	Clogged filter	For filter bag and cartridge filter cleaning; please see operation instruction. NCF filter cleaning; check filter cleaning function by listening to noise from blow-out valve. If not in operation, check quick coupling and function of blow-out valve.
	Leaking suction hose	Tape or replace suction hose.
	Leaking gaskets	Damage on neoprene gasket; remove and replace. Use suitable two-component glue.
	Discharge valve open.	Close valve
Dust in exhaust air	Filter wrongly or not installed	Check the filter and change if necessary.
	Filter defect	Change filter.
Water in exhaust air	Filter basket or float ball wrongly or not installed	Reattach filter basket or float ball. Please see operation instruction.
	Filter basket or float ball defect	Change.
Abnormal noise level	Leaking gaskets	Damage on neoprene gasket; remove and replace. Use suitable two-component glue.
	Sound absorbing material defect	Dismantle the silencer hood and remove dirt. Replace damaged silencing material.

CUSTOMER: _____

VACUUMER TYPE/MODEL: _____

SERVICE DATE _____ SERVICED BY: _____

		OK	Repaired	Replaced	Replaced part number
1.0	CONTROL WITHOUT RUNNING, OUTSIDE				
1.1	Silencer				
1.2	Compressed air hose				
1.3	Container(s)				
1.4	Trolley				
1.5	Suction hose(s)				
1.6	Preseparator/cyclone				
1.7	Accessories				
1.8	Other items, specify				
2.0	CONTROL WITHOUT RUNNING, INSIDE				
2.1	Gasket(s)				
2.2	Lid, vacuum head				
2.3	Container(s)				
2.4	Filter(s)				
2.5	Dustbag				
2.6	Float ball				
2.7	Other items, specify				
3.0	CONTROL RUNNING, (TOP COVER INSTALLED)				
3.1	Start/stop switch function				
3.2	Vacuum				
3.3.	Noise level				
4.0	CONTROL RUNNING, (TOP COVER DISMANTLED)				
4.1	Rotation motors				
4.2	Thermoswitch function				
5.0	CONTROL WITHOUT RUNNING, (TOP AND SECONDARY COVERS DISMANTLED)				
5.1	Electric cable connections				
5.2	Carbon brushes				
5.3	Commutator wear				
5.4	Motor wear				
5.5	Radio disturbance compression card				

		OK	Repaired	Replaced	Replaced part number
6.0	OTHER ITEMS (SPECIFY)				
6.1					
6.2					
6.3					
6.4					
6.5					
6.6					
6.7					
6.8					
6.9					



WARNING! Risk of Personal injury

Disconnect the vacuum cleaner before doing any service.

- 1.2 Control the cable and plug, and replace it if damaged.
- 1.5 Replace leaking suction hoses and couplings.
- 2.1 Replace worn out, aged and leaking gaskets.
- 2.4 Repair or replace worn out filters to avoid wear and tear of the turbine rotor, or blow through of health hazardous materials.
- 2.5 Replace torn or full antistatic dust bag.
Repair or replace reusable dust bag. If it is clogged, wash or shake it clean.
- 2.6 Clean the water level limiting device regularly and examine it for signs of damage.
- 3.1 Start the motors in sequence using the main switch.
If the main switch does not function properly or is damaged, replace it.
- 3.2 If specified vacuum is not reached, check all gaskets and connections.
Execute the vacuum test with suction inlet(s) closed.
- 3.3 If the noise level is higher than the maximum specified, dismantle the silencer hood and check the silencing material.
Replace it if damaged.
- 4.1 Start the vacuum with the top cover removed.
Control that the motors are running clockwise as seen from above.



WARNING! Risk of Personal injury

Do not touch the motor directly or with any tool during this operation.

- 4.2 Control the thermal function by clogging the cooling air inlets with sheets of paper. The vacuum should soon stop without getting overheated (about 75°C/167 °F).
- 5.1 Control that all cable connections are properly secured and screws tightened.
- 5.2 Control that the carbon brushes are not worn out. Replace them if necessary.
Replace after about 900 hours. Replaced brushes must be checked after 500 hours.
- 5.3 Control wear of commutator. Replace motor if commutator is grooved.
- 5.4 Turn motor. If there is resistance in bearings or turbo fan, replace the motor.
- 5.5 If any wiring in the printing card is burned, replace the card.

Model specification

Description: Bb216 - NEL3R, S50, 2.5/2.4kW 230V 50/60Hz

Model: 42421629

Code no.	Description	Qty.
43054100	NEL3R, S50 2.5/2.4kW 230V 50/60Hz	1
43120200	Absolute filter L=220 A=1.56m ² wo/perf.plate	1
43140010	Clamp f/cartr.filter M10 L=90 EI-Zn	1
43332001	Container S50 47l w/ecc fastners	1
43424001	Silo S50 w/rev air clean	1
43723001	Trolley S50 f/silo	1
43811001	Suction hose PE d38 L=5m antistatic w/swivel male conn	1

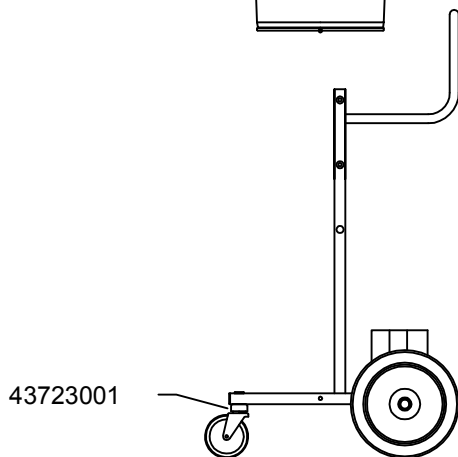
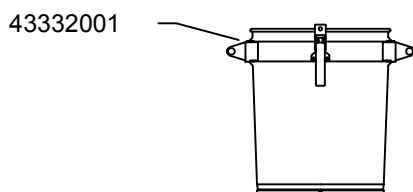
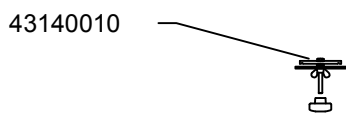
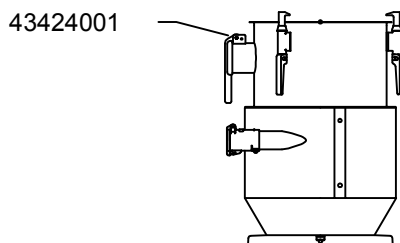
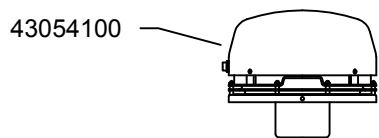



MAX 40°C

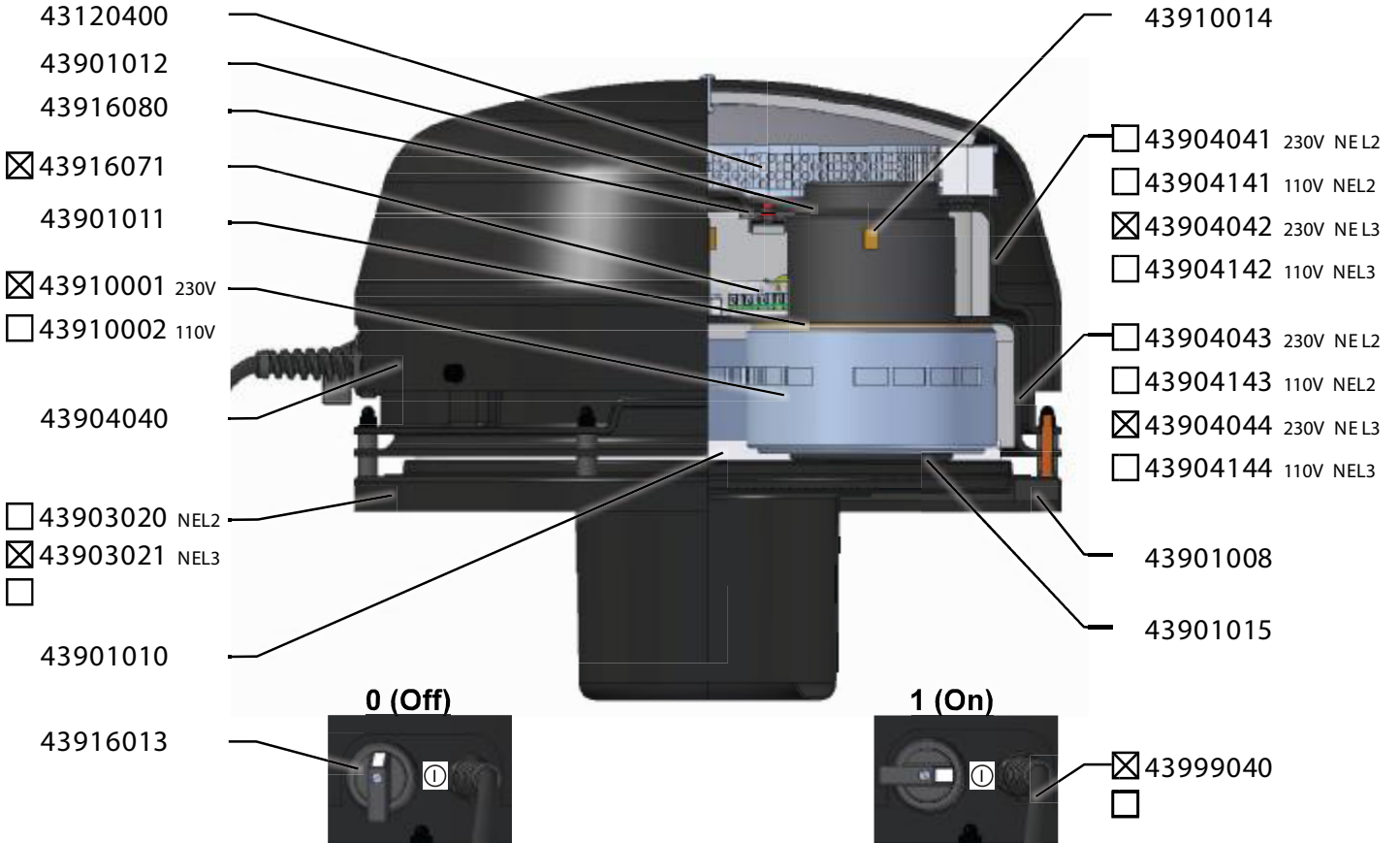

Vacuum producer		kW	V	Hz	Max. vacuum mmWC	-kPa	Max. a ir flow Nm ³ /hr	Noise level* dB(A)
<input type="checkbox"/> NEL2 R	IP44	1.7/1.6	230	50/60	2150	21,5	312	78,7
<input checked="" type="checkbox"/> NEL3 R	IP44	2.5/2.4	230	50/60	2150	21,5	460	79,7
<input type="checkbox"/> NEL3 RT	IP44	2.5/2.4	230	50/60	2150	21,5	460	79,7
<input type="checkbox"/> NEL 2	IP44	1.6/1.7	110	50/60	2000	20	312	78,7
<input type="checkbox"/> NEL 3	IP44	2.4/2.6	110	50/60	2000	20	460	79,7
<input type="checkbox"/> NEL3 T	IP44	2.4/2.6	110	50/60	2000	20	460	79,7

*Noise level - distance: 1,1 m - height: 1,6 m

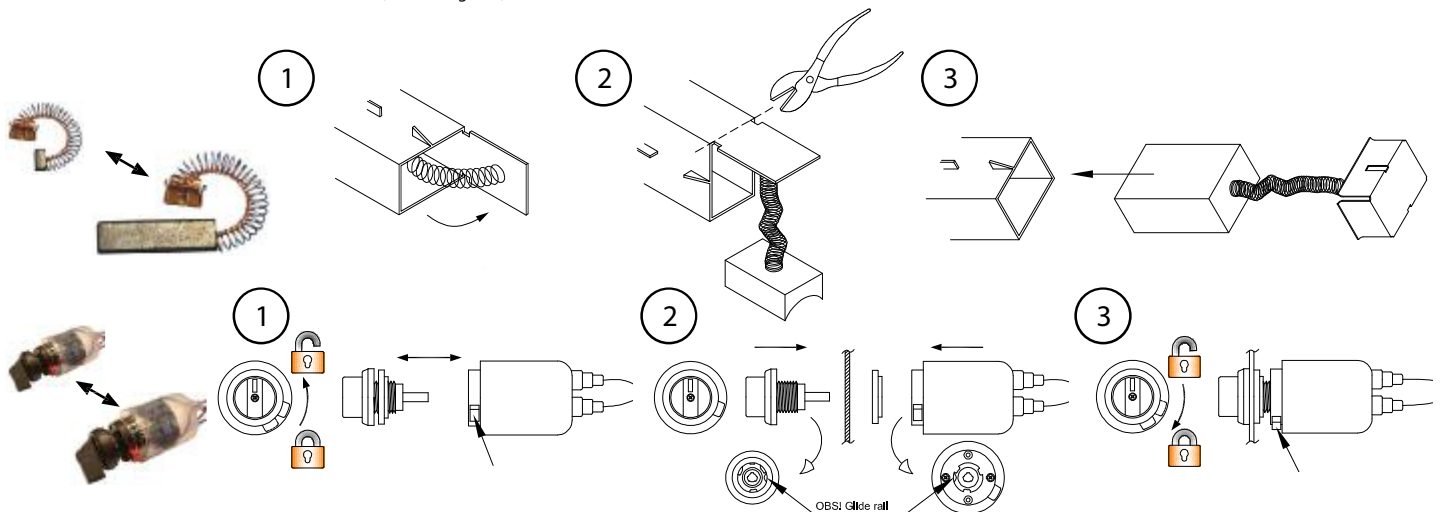

43 0 54 100



NEL2

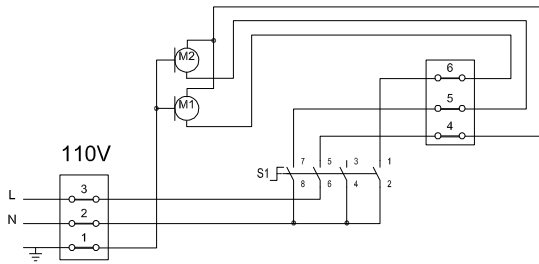

NEL3

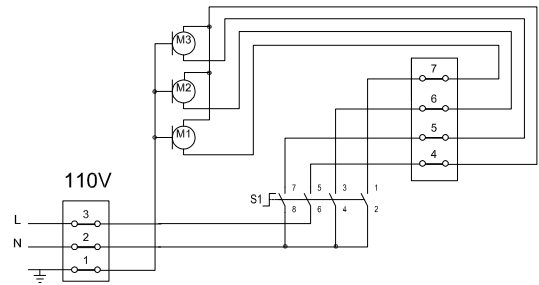

NEL2R

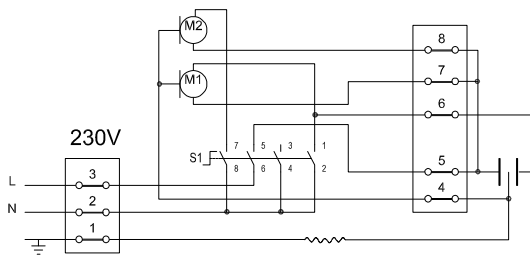

NEL3R

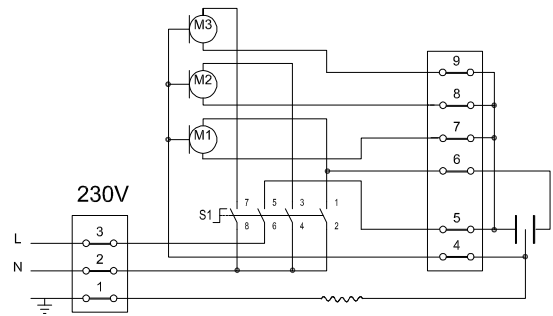

NEL3T

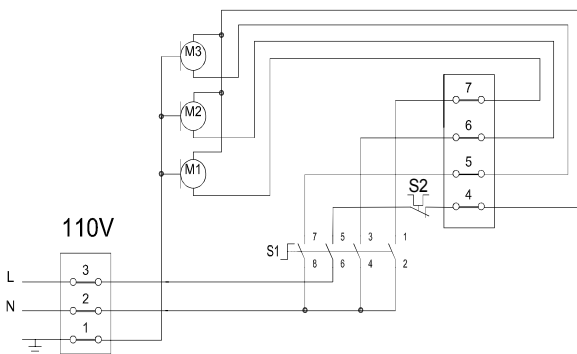

NEL3RT

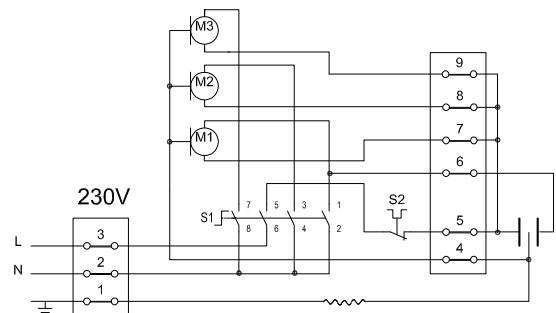

43 0 54 100



1

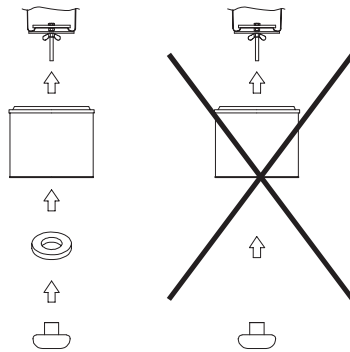
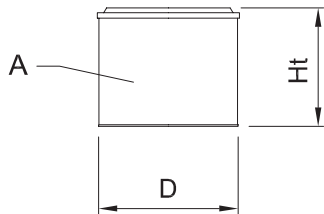

2

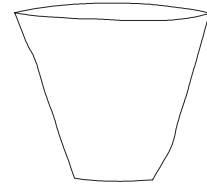

3

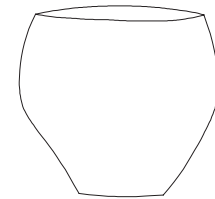

	Product number:	Area m ²	Max. temp. °C	Diameter mm	Height mm	Weight kg	BIA	EN 60335-2-69	Antistatic	Washable	*End plate
<input type="checkbox"/>	43110001	0,5	70	-	-	0,6	-	-	-	-	-
<input type="checkbox"/>	43110100	0,4	120	-	-	0,2	-	-	-	-	-
<input type="checkbox"/>	43110200	0,4	120	-	-	0,2	-	-	x	-	-
<input type="checkbox"/>	43110300	0,6	120	-	-	0,4	-	-	-	-	-
<input type="checkbox"/>	43110400	0,6	120	-	-	0,4	-	-	x	-	-
<input type="checkbox"/>	43120100	2,4	70	264	220	1,0	U,S,G,C	M	-	-	-
<input type="checkbox"/>	43130001	2,4	70	264	220	2,0	U,S,G,C	M	-	-	-
<input type="checkbox"/>	43130100	2,4	70	264	220	1,0	U,S,G,C	M	-	-	-
<input type="checkbox"/>	43130200	5,4	70	264	470	2,0	U,S,G,C	M	-	-	-
<input type="checkbox"/>	43130201	5,4	70	264	470	3,0	U,S,G,C	M	-	-	-
<input type="checkbox"/>	43130300	6,9	70	264	600	3,0	U,S,G,C	M	-	-	-
<input type="checkbox"/>	43130301	6,9	70	264	600	4,0	U,S,G,C	M	-	-	-
<input type="checkbox"/>	43130400	10,0	70	264	870	5,0	U,S,G,C	M	-	-	-
<input type="checkbox"/>	43130401	10,0	70	264	870	5,0	U,S,G,C	M	-	-	-
<input type="checkbox"/>	43130500	1,6	70	264	220	2,0	K1/K2	H	-	-	-
<input checked="" type="checkbox"/>	43120200	1,6	70	264	220	2,0	K1/K2	H	-	-	-
<input type="checkbox"/>	43130700	3,5	70	264	470	3,0	K1/K2	H	-	-	-
<input type="checkbox"/>	43130702	3,5	70	264	470	4,0	K1/K2	H	-	-	-
<input type="checkbox"/>	43130800	4,5	70	264	600	3,0	K1/K2	H	-	-	-
<input type="checkbox"/>	43130801	4,5	70	264	600	3,0	K1/K2	H	-	-	-
<input type="checkbox"/>	43130900	6,5	70	264	870	4,0	K1/K2	H	-	-	-
<input type="checkbox"/>	43130901	6,5	70	264	870	6,0	K1/K2	H	-	-	-
<input type="checkbox"/>	43120300	2,4	120	264	220	2,0	U,S,G,C	M	-	x	-
<input type="checkbox"/>	43120301	2,4	120	264	220	2,0	U,S,G,C	M	x	x	GS
<input type="checkbox"/>	43120303	10,0	120	264	87	2,0	U,S,G,C	M	x	x	-
<input type="checkbox"/>	43120304	2,4	120	264	220	2,0	U,S,G,C	M	x	x	A4
<input type="checkbox"/>	43120400	0,7	80	338	42	0,8	U,S,G,C	M	-	-	-

* A2 = AISI 304 / A4 = AISI 316L / GS = Galvanized steel

43 1 20 200



S235JR(St37.2)

- 43999021
- 43999721 A4

- 43999031
- 43999531

- 43999003
- 43885001

- 43909003
- 43909103 A4
-

- 43907013
- 43907015

- 43907004
- 43907104

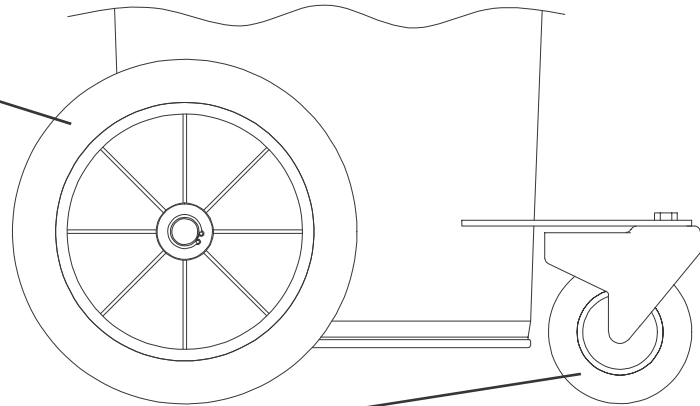
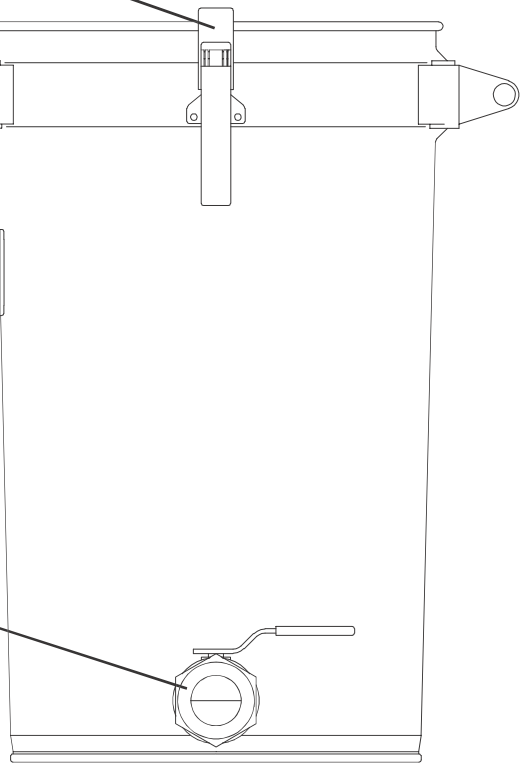

43 3 32 001



43903100

43885001

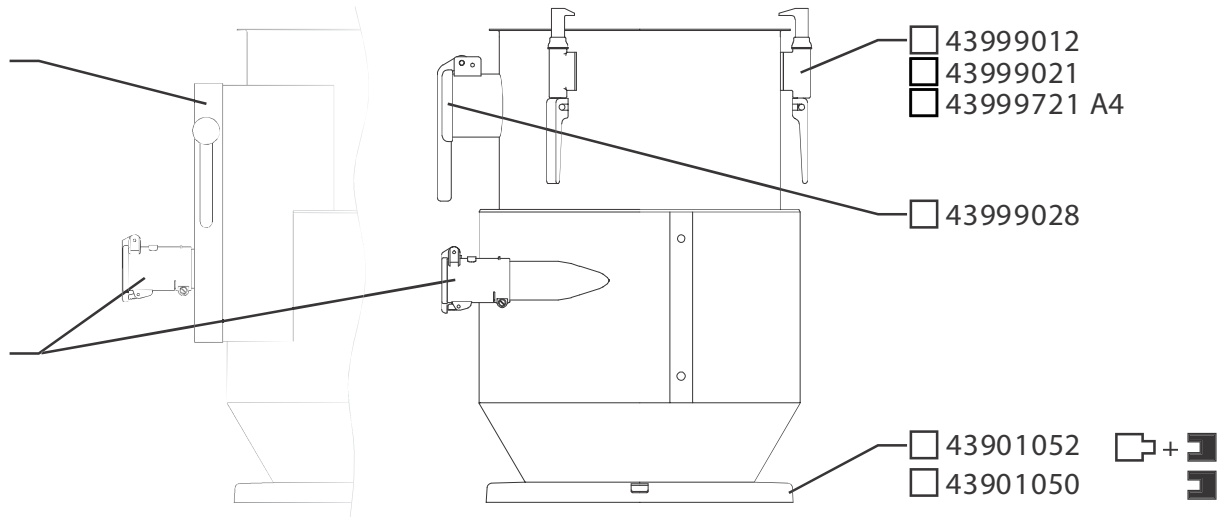

- EN Filter cleaning
- SE Filterrengöring
- FI Suodattimen puhdistus
- DE Filterabreinigung
- DK Filter rengøring

Automatic

Manual

1. EN Unit have to run.
SE Enheten måste köra.
FI Imurin on oltava käynnissä.
DE Sauger muß laufen.
DK Enhed nødt til at løbe.

2. EN Working
SE Arbetar
FI Työ
DE Arbeiten
DK Arbejde



3. EN Filter cleaning.
SE Filterrengöring.
FI Suodattimen puhdistus.
DE Filterabreinigung.
DK Filter rengøring.



Manual

1. EN Unit have to run.
SE Enheten måste köra.
FI Imurin on oltava käynnissä.
DE Sauger muß laufen.
DK Enhed nødt til at løbe.

2. EN Remove hose.
SE Ta bort slangen.
FI Irroita imuletku..
DE Saugschlauch entfernen.
DK Fjern slangen.

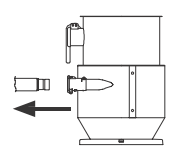

3. EN Open and close lid.
SE Öppna och stäng locket.
FI Avaa ja sulje läppä.
DE Deckel öffnen und wieder schließen.
DK Åbne og lukke låget.

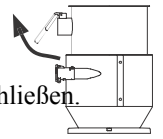



43903100

43885001

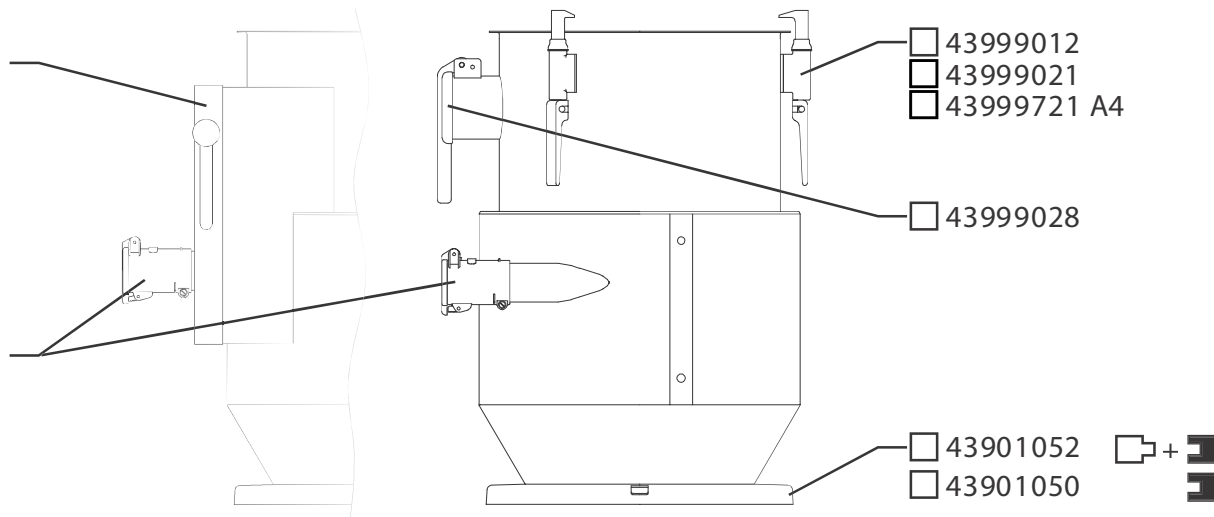

- NO Filterrensjøring
- NL Filterreiniging
- HU Szűrő tisztítása
- PL Czyszczenia filtra
- ES Limpieza del filtro

Automatic

Manual

1. NO Suger må gå.
 NL Eenheid hebban om te draaien.
 HU Egység kell indítanunk.
 PL Jednostka uruchomić.
 ES Unidad tiene que ejecutar.

2. NO Arbeide
 NL Werken
 HU Dolgozó
 PL Praca
 ES De Trabajo



3. NO Filterrensjøring
 NL Filterreiniging
 HU Szűrő tisztítása
 PL Czyszczenia filtra
 ES Limpieza del filtro



Manual

1. NO Suger må gå.
 NL Eenheid hebban om te draaien.
 HU Egység kell indítanunk.
 PL Jednostka uruchomić.
 ES Unidad tiene que ejecutar.

2. NO Fjern slange.
 NL Verwijder de slang.
 HU Eltávolítás tömlőt.
 PL Usuń węża.
 ES Retire la manguera.

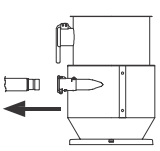

3. NO Løkk åpnes og lukkes.
 NL Open en sluit het deksel.
 HU Nyissa ki és zárja a fedelet.
 PL Otwórz i zamknij pokrywę.
 ES Abra y cierre la tapa.

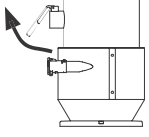



43903100

43885001

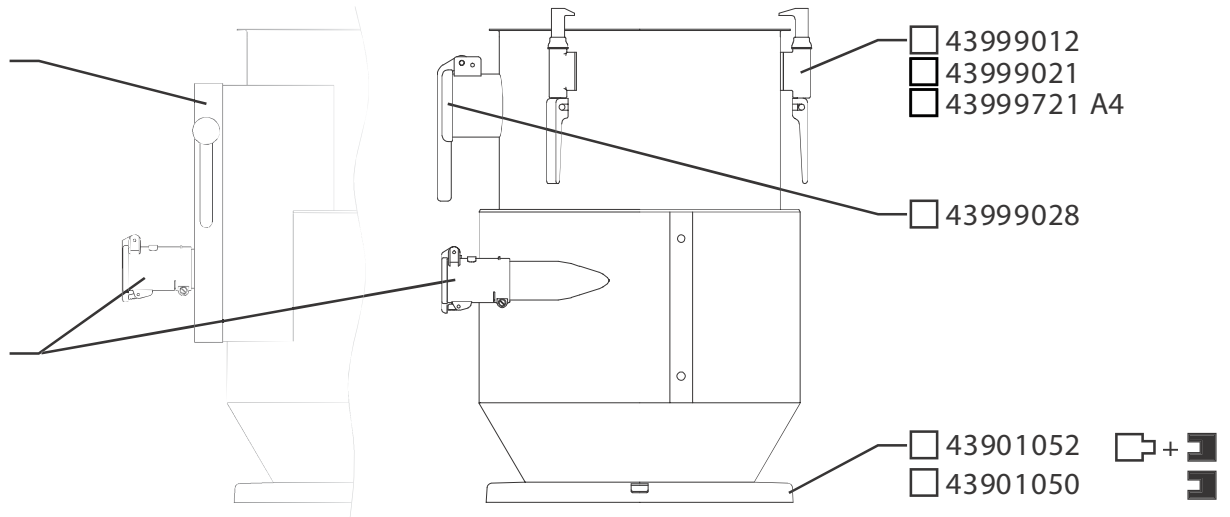

- RO Filtru de curățare
- IT Pulizia del filtro
- FR Nettoyage du filtre
- CZ Čištění filtru
- RU Очистка фильтра

Automatic

Manual

1. RO Unitatea trebuie să ruleze.
IT Unità deve eseguire.
FR Unité à courir.
CZ Jednotka musí běžet.
RU Группы должны запустить.

2. RO De lucru
IT Lavoro
FR De travail
CZ Pracovní
RU Рабочая



3. RO Filtru de curățare
IT Pulizia del filtro
FR Nettoyage du filtre
CZ Čištění filtru
RU Очистка фильтра



Manual

1. RO Unitatea trebuie să ruleze.
IT Unità deve eseguire.
FR Unité à courir.
CZ Jednotka musí běžet.
RU Группы должны запустить.

2. RO Demonta furtunul.
IT Rimuovere il tubo.
FR Retirer le tuyau.
CZ Odstraňte hadici.
RU Удалить шланга.

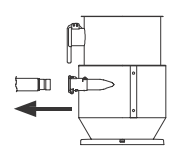

3. RO Deschideți și închideți capacul.
IT Aprire e chiudere il coperchio.
FR Ouvrir et fermer le couvercle.
CZ Otevřete a zavřete víko.
RU Откройте и закройте крышку.

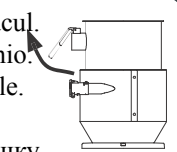



S235JR(St37.2)

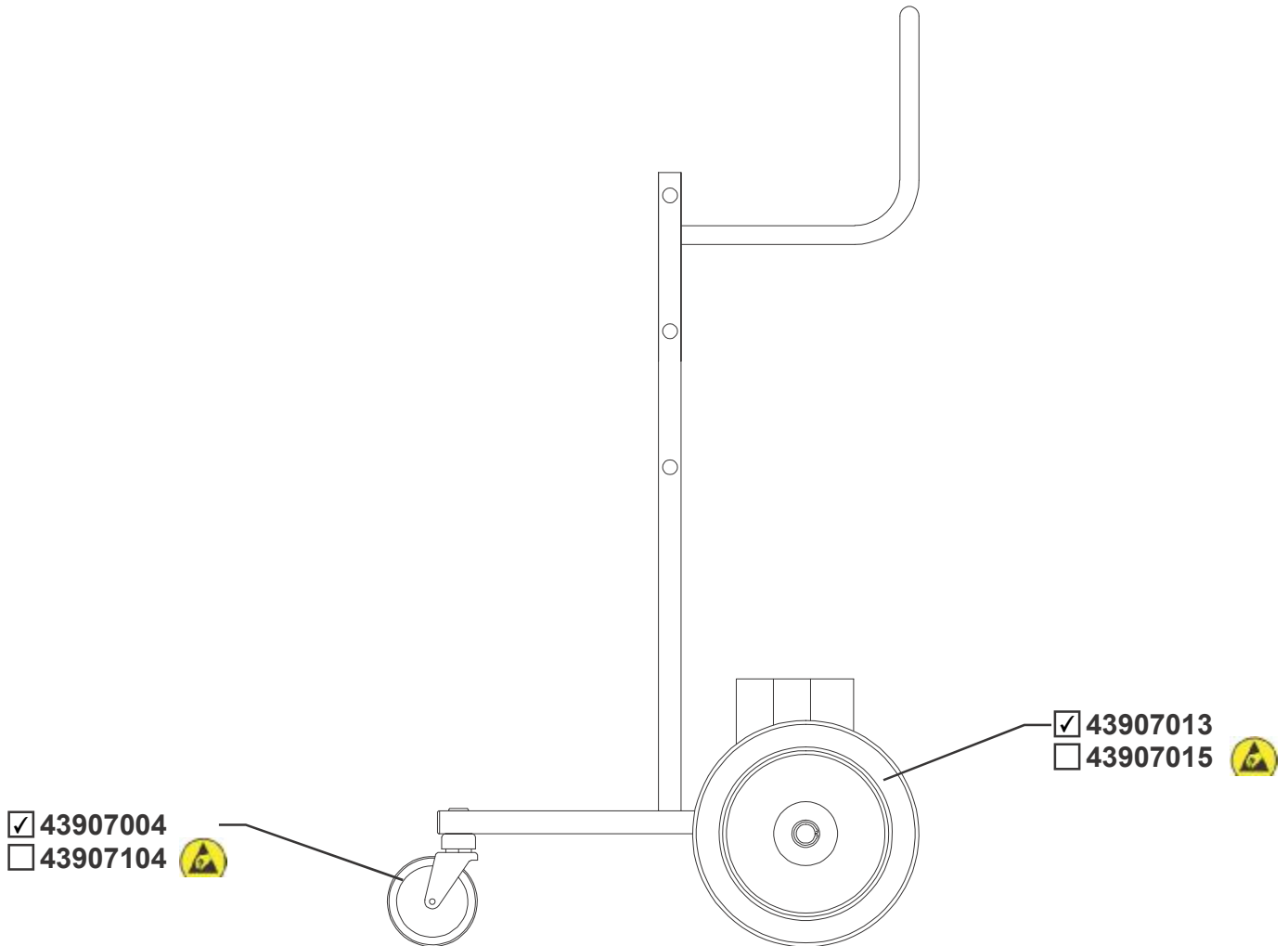

43 7 23 001

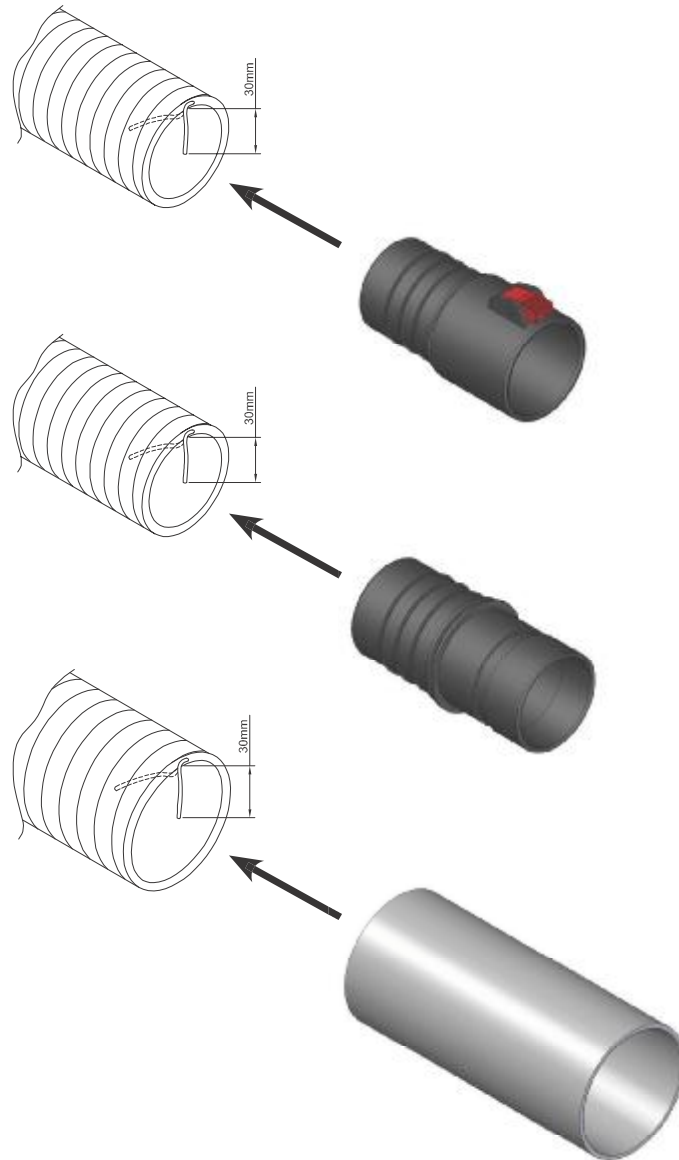

	Material	C°/F°
<input checked="" type="checkbox"/>	PE	-40°C - +60°C -40°F - +140°F
<input type="checkbox"/>	PVC	-20°C - +70°C -4°F - +158°F
<input type="checkbox"/>	PUR	-40°C - +90°C -40°F - +194°F

43 8 11 001

Addendum to Manual



NEL	-mmWC	-kPa	Nm ³ /hr
2	2150	21,5	312
2R	2150	21,5	312
3	2150	21,5	460
3R	2150	21,5	460
3RT	2150	21,5	460

NEL

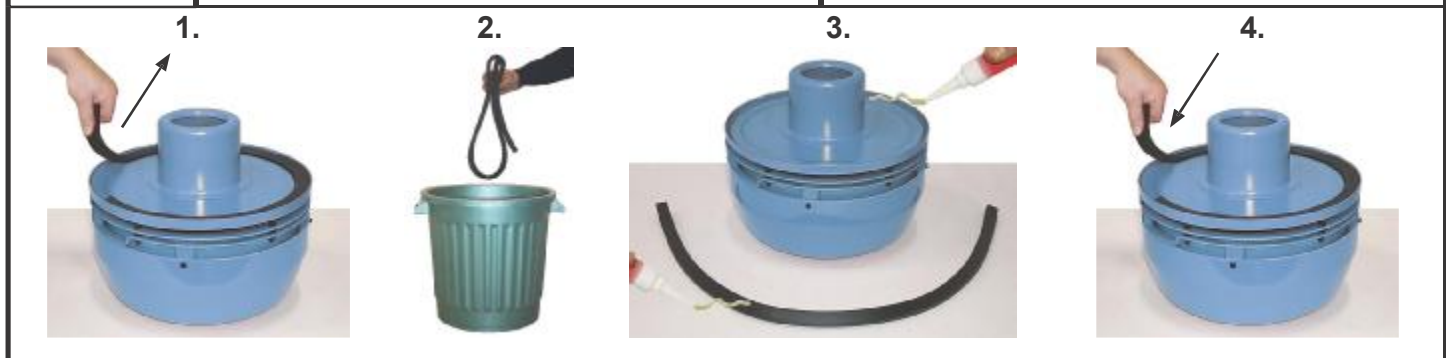
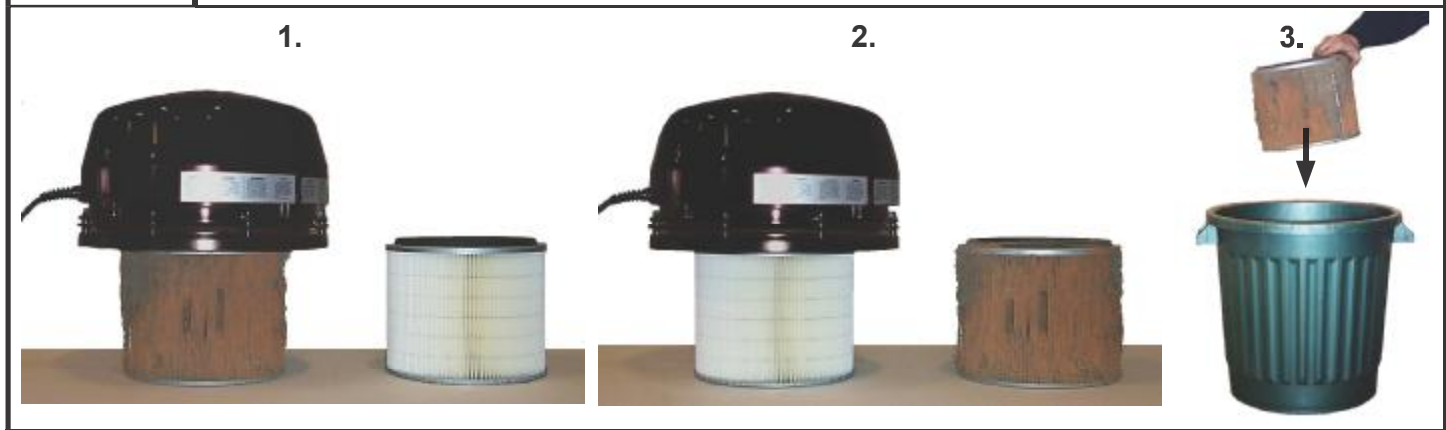
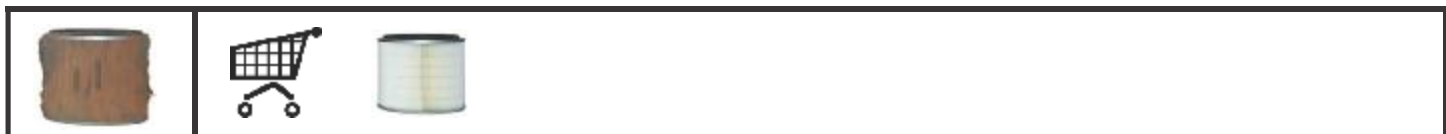
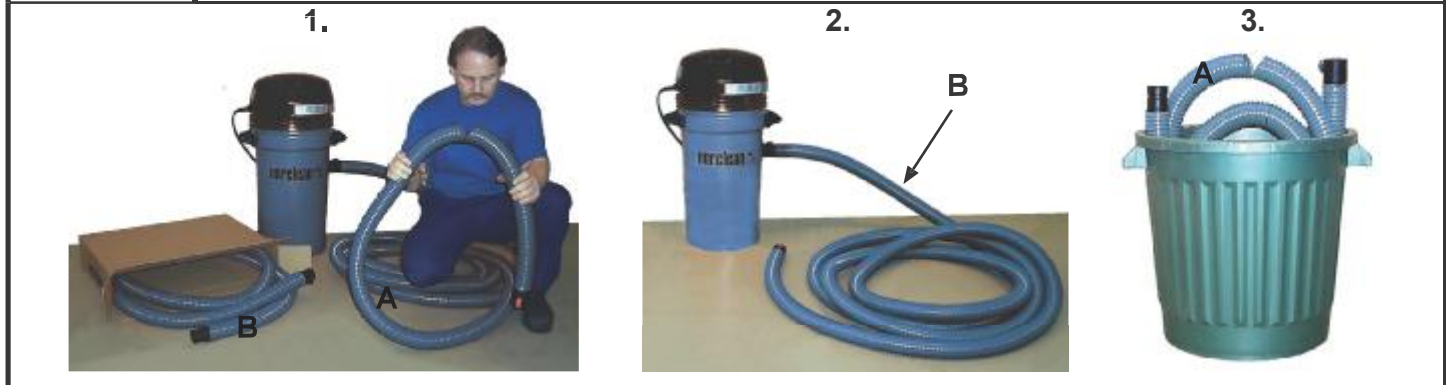
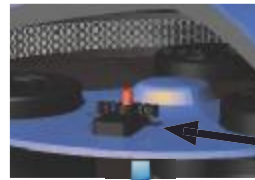

	 A 	 B  10mm	C  22mm	D 	E 
1. 	2. 	3. 	4. 		
5. 	6. 	7. 			
8. 	9. 	10. 	11. 		
	 1 x 😊	 2 x 😊	 3 x ☹️		

